

Precision Clean Regulator

Series SRP



High precision, low flow consumption stainless steel regulator

ARJ

AR425
to 935

ARX

AMR

ARM

ARP

IR

IRV

VEX

SRH

SRP

SRF

VCHR

ITV

IC

ITVX

PVQ

VEF
VEP

VER

VEA

VY1

VBA
VBAT

AP100

Precision Clean Regulator *Series SRP*

High precision, low flow consumption stainless steel regulator



Achieves flow consumption "under a liter"

Bleed volume
0.5 L/min (ANR) or less
(Outlet pressure at 0.2 MPa)

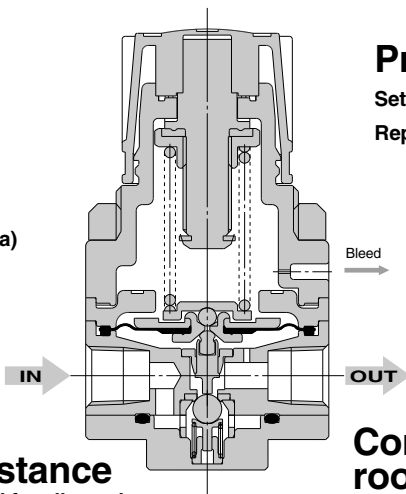

Precision

Setting sensitivity: 0.3%F.S.

Repeatability: 1%F.S.

Oil free

Parts composition with no use of oils.

All wetted parts degrease washing

Excellent corrosion resistance

Stainless steel 316 is used for all metal parts in contact with the fluid.

Consistent clean room production

Cleaned, assembled, inspected, and sealed in double packaging in a Class 10,000 environment

Applications

Pressure feed of chemicals

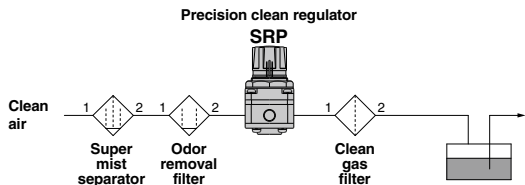

N2 blow

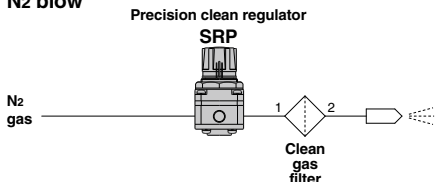

Manufacturing process

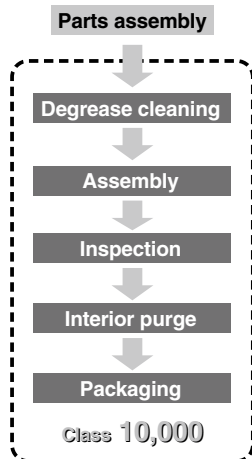

Precision Clean Regulator

Series *SRP*

How to Order



Symbol

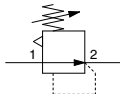

SRP 1 1 0 1-01 - -

Set pressure

0	0.005 to 0.2 MPa
1	0.01 to 0.4 MPa

Port size

Symbol	Piping port size
M5	M5 x 0.8
01	Rc 1/8

Made to Order

(Refer to page 776 for details.)

Nit	Standard
X201	Machined bleed port M5 thread
X206	With bleed port fittings (Applicable tube O.D.: ø4)

Gauge port orientation

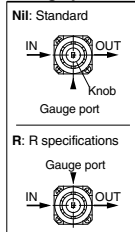

* Gauge port positions are indicated with the knob on the top side.

Options

Bracket

Model	Material
B21-1-T1	Rolled steel plate (electroless nickel plated)

Pressure gauge

Product part no.	Pressure gauge part no.
SRP1***-M5	IN-233-863+G46-□-01M-SRB
SRP1***-01	G46-□-01-SRB

Specifications

Connection port size		M5, Rc 1/8
Fluid		Air, N ₂ , CO ₂ , Ar
Proof pressure MPa		1.5
Maximum operating pressure MPa		1.0
Regulating pressure range MPa	Low pressure type	0.005 to 0.2
	High pressure type	0.01 to 0.4
Ambient and fluid temperature (°C)		0 to 60
Fluid consumption L/min (ANR) ^(Note)		0.5 or less
Sensitivity		0.3% of full span
Repeatability		± 1% of full span
Fluid-contact parts	Metal	Stainless steel 316
	Resin	Fluororesin
	Rubber	Fluororubber
	Other	Ceramics
Assembly environment		Clean room class 10000
Parts cleaning		All wetted parts degrease washing

(Note) At set pressure of 0.2 MPa

ARJ

AR425
to 935

ARX

AMR

ARM

ARP

IR

IRV

VEV

SRH

SRP

SRF

VCHR

ITV

IC

ITVX

PVQ

VEF
VEP

VER

VEA

VY1

VBA
VBAT

AP100

Flow Characteristics (Representative value)

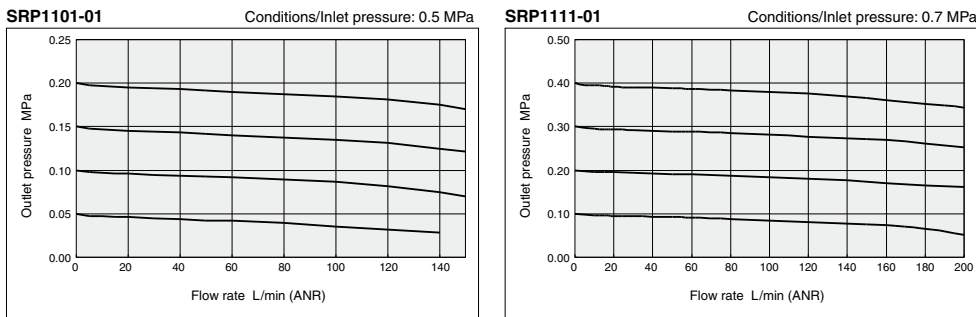
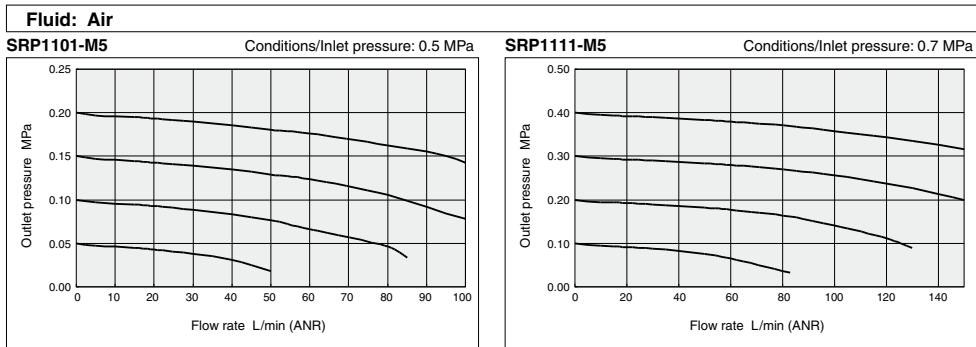

Pressure Characteristics (Representative value)

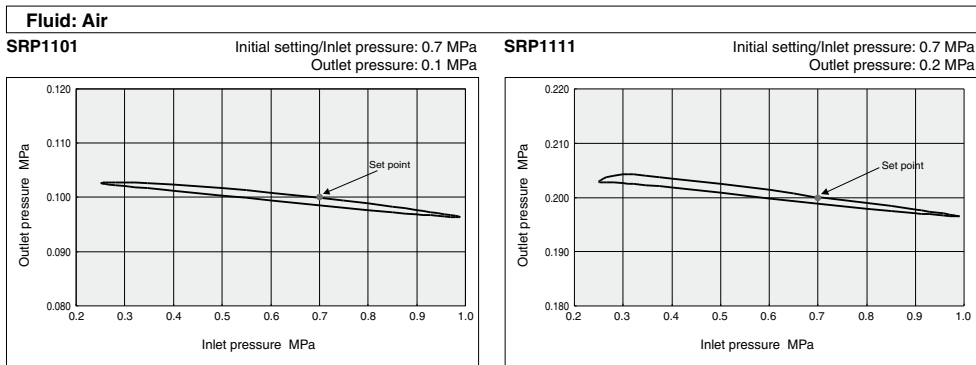

Construction

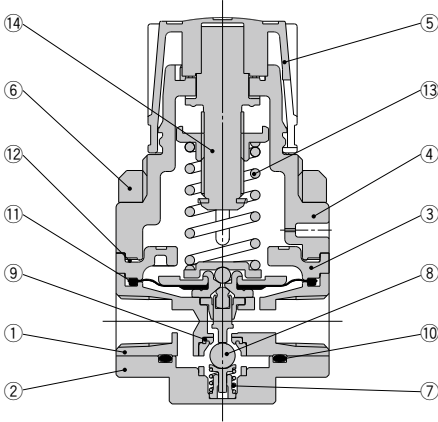

Component parts

No.	Description	Material	Treatment
1	Body	Stainless steel 316L	
2	Valve guide	Stainless steel 316	
3	Spacer	PPS	
4	Bonnet	PPS	
5	Knob	PBT	
6	Set nut	ZDC	Electroless nickel plated
7	Valve spring	Stainless steel 316	
8	Main valve	Ceramics	
9	Valve seat	PTFE	
10	O-ring	Fluororubber	
11	Diaphragm	Fluororubber	
12	Gasket	Fluororubber	
13	Pressure regulator spring	Steel wire	
14	Pressure regulator screw assembly	—	

Dimensions

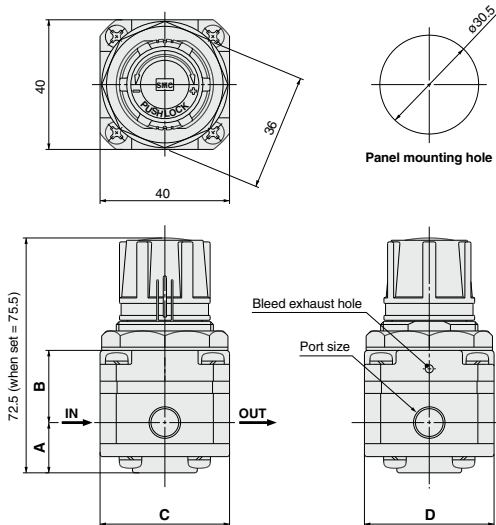

Bracket

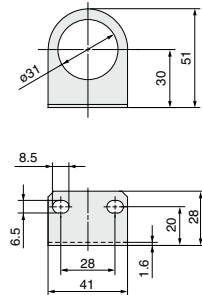

Model	Port size	A	B	C	D
SRP11□1-M5	M5 x 0.8	14	23.5	30	30
SRP11□1-01	Rc 1/8	15	22.5	40	40

Series SRP Made to Order Specifications:

Contact SMC for detailed dimensions, specifications and delivery.



Symbol
X201

1 Machined Bleed Port M5 Thread

Regulator with a M5 thread machined on the relief port in order to connect it to the bleed port.

Standard model no. — X201

• Machined bleed port M5 thread

Dimensions

Other dimensions are the same as the standard type.

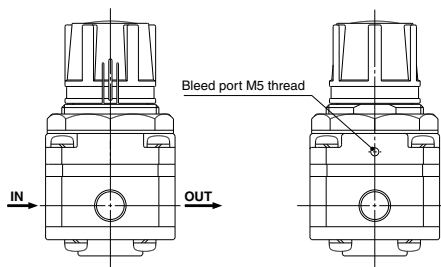

2 With Bleed Port Fittings (Applicable Tubing O.D.: $\varnothing 4$)

Symbol
X206

Regulator with a fitting in order to connect it to the bleed port.

Standard model no. — X206

• With bleed port fittings

Dimensions

Other dimensions are the same as the standard type.

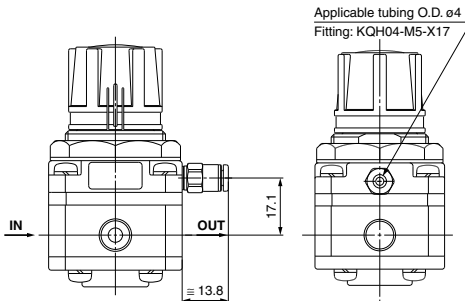



Series SRP

Specific Product Precautions

Be sure to read before handling.

Refer to front matter 43 for Safety Instructions and pages 365 to 369 for Precautions on every series.

Design and Selection

Warning

1. Types of fluid

This product is designed for use with air, N₂, CO₂ and Ar as fluids. Consult SMC if it will be used with any other fluids.

Since this product uses a bleed mechanism and fluid is released from the bleed hole, poisonous or corrosive gases cannot be used.

2. Fluids containing solids cannot be used.

Since this can cause malfunction, install a mist separator, etc., upstream from the regulator.

3. For air containing a large amount of drainage, install an air dryer or after cooler, etc., upstream from the regulator.

This can otherwise cause malfunction.

4. Do not use in locations subject to vibration or impact.

5. Avoid direct sunlight by providing a protective cover, etc.

6. When sources of heat are located nearby, block off any radiated heat.

Caution

1. It is recommended that the outlet pressure be set in the range of 25 to 85% of the inlet pressure.

2. Depends on operating conditions, oscillation (buzz) may occur even when used within the specification range detailed in this catalog. Consult SMC for details.

Mounting

Caution

1. Open the sealed package inside a clean room.

This product is packaged in sealed double packaging in a clean room. It is recommended that the inside packaging be opened in a clean room or other clean environment.

2. Flush out the piping.

Connect this product to piping only after the piping has been flushed or washed, etc. If debris or scale, etc., remains in the piping, this can cause malfunction or failure.

3. Keep sealing material from getting inside the piping.

When screwing in pipes and fittings, etc., take care that chips from the pipe threads, sealing material, and other debris do not get inside the piping. If debris or scale, etc., remain inside the piping, this can cause malfunction or failure. Also, when pipe tape is used, leave 1.5 to 2 threads ridges exposed at the end of the threads.

4. Confirm the mounting orientation of the product.

The side marked IN is the fluid inlet, and the side marked OUT is the fluid outlet. If mounted backwards, the product will not operate properly.

5. Do not block the bleed hole.

If the bleed hole is blocked, the product will not operate properly.

Pressure Adjustment

Warning

1. Do not use tools when operating the pressure regulator knob.

If tools, etc., are used to operate the pressure regulator knob, damage can occur. Operate this knob only by hand.

2. Perform settings while confirming inlet and outlet pressure indicators.

Turning the knob more than necessary can cause damage to internal parts.

Caution

1. Perform pressure adjustments only after releasing the lock.

When the pressure regulator knob will not turn, it is locked. Release the lock by pulling the pressure regulator knob out. If the knob is turned by force damage will occur.

After adjusting the pressure, lock the knob again by pressing it back down.

2. Adjust pressure in an upward direction.

A correct pressure setting cannot be achieved by adjusting the pressure downward. The outlet pressure is increased by turning the pressure regulator knob to the right, and decreased by turning the knob to the left.

3. Confirm the inlet pressure.

Set the outlet pressure to no more than 85% of the inlet pressure. If the inlet pressure is too low, a correct set pressure cannot be attained.

4. A small volume of fluid will be expended from the bleed hole.

The bleed mechanism is used to perform high precision pressure adjustment. Therefore, it is not abnormal for a small volume of fluid to be expended from the bleed hole.

ARJ

AR425
to 935

ARX

AMR

ARM

ARP

IR

IRV

VEV

SRH

SRP

SRF

VCHR

ITV

IC

ITVX

PVQ

VEF
VEP

VER

VEA

VY1

VBA
VBAT

AP100