

Vacuum Release Valve with Restrictor

Series *SJ3A6*

Plug-in Type Connector Connection

P.86

D-sub Connector
Flat Ribbon Cable
PC Wiring
Serial Wiring: EX180
Serial Wiring: EX510

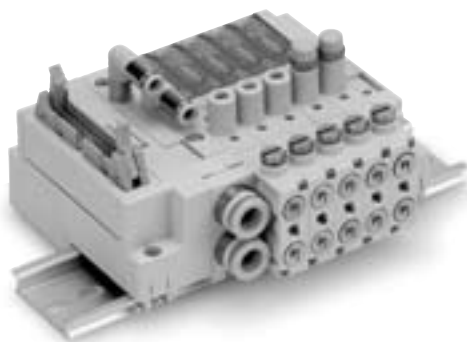

Non Plug-in Type Individual Wiring

P.90

Individual Wiring



SJ

SY

SV

SYJ

SZ

VP4

S0700

VQ

VQ4

VQ5

VQC

VQZ

SQ

VFS

VFR

VQ7

Vacuum Release Valve with Restrictor Common Specifications Series SJ3A6

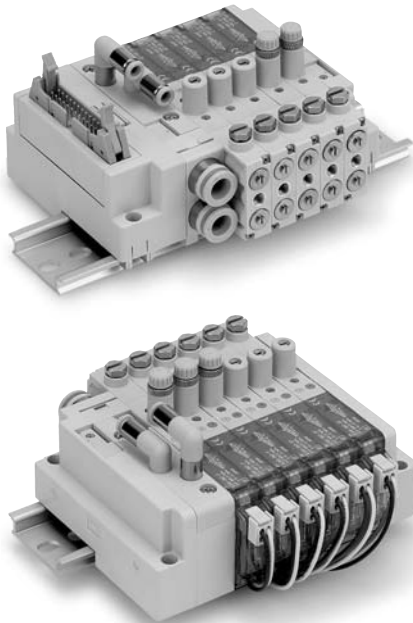

Manifold Valve Specifications

Valve construction		3 position 3 port valve with restrictor
Fluid		Air
Operating pressure range (MPa)	Release pressure port 1(P)	0.25 to 0.7
	Vacuum pressure port 3/5(E)	-100 kPa to 0.7 ^{Note 1)}
	Pilot X port	0.25 to 0.7 ^{Note 2)}
Ambient and fluid temperature (°C)		-10 to 50 (No freezing)
Max. operating frequency (Hz)		3
Manual override (Manual operation)		Non-locking push type
		Push-turn locking slotted type
Restrictor operation		Manual
		Slotted locking type
Pilot method		External pilot/Pilot valve individual exhaust
Lubrication		Not required
Mounting orientation		Unrestricted
Impact/Vibration resistance (m/s²) ^{Note 3)}		150/30
Enclosure		Dustproof

Note 1) Can be used with positive pressure to suit the application.

Note 2) Please use with pilot X port pressure equal to or higher than the release port 1(P) pressure.

Note 3) Impact resistance: No malfunction occurred when it is tested in the axial direction and at the right angles to the main valve and armature in both energized and de-energized states every once for each condition. (Values at the initial period)

Vibration resistance: No malfunction occurred in a one-sweep test between 45 and 2000 Hz. Test was performed at both energized and de-energized states in the axial direction and at the right angles to the main valve and armature. (Values at the initial period)

JIS symbol

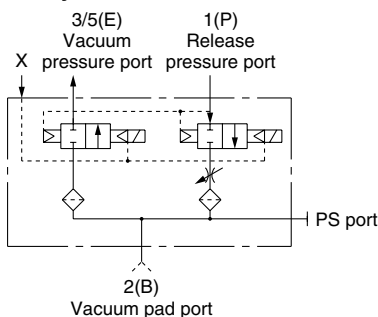

Solenoid Specifications

Coil rated voltage		24 VDC, 12 VDC
Allowable voltage fluctuation		±10% of rated voltage*
Power consumption (W)	Standard	0.4
	With power saving circuit (Continuous duty type)	0.15
Surge voltage suppressor		Diode
Indicator type		LED

* For the allowable voltage fluctuation for Z/T type (with power saving circuit), please observe the following range because they have voltage drop due to internal circuit.

Z type 24 VDC: -7% to +10%
12 VDC: -4% to +10%
T type 24 VDC: -5% to +10%
12 VDC: -6% to +10%

Response Time

Valve model	Response time ms (at 0.5 MPa)
SJ3A6-□□-□	19 or less

Mass

Valve model	Mass (g)
SJ3A6-□□-P	79

Flow Characteristics

Flow Characteristics (When restrictor is fully open)

Valve model	Fluid passage 1(P)→2(B)			2(B)→3/5(E)			
	2(B) Port size	C [dm ³ /(s·bar)]	b	Cv	C [dm ³ /(s·bar)]	b	Cv
SJ3A6-□□-□	M5	0.24	0.19	0.05	0.40	0.18	0.10

Restrictor Flow Characteristics [Fluid passage: 1(P)→2(B)]

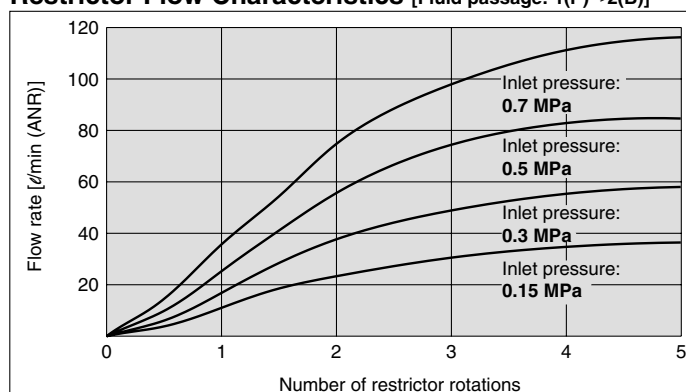

Construction

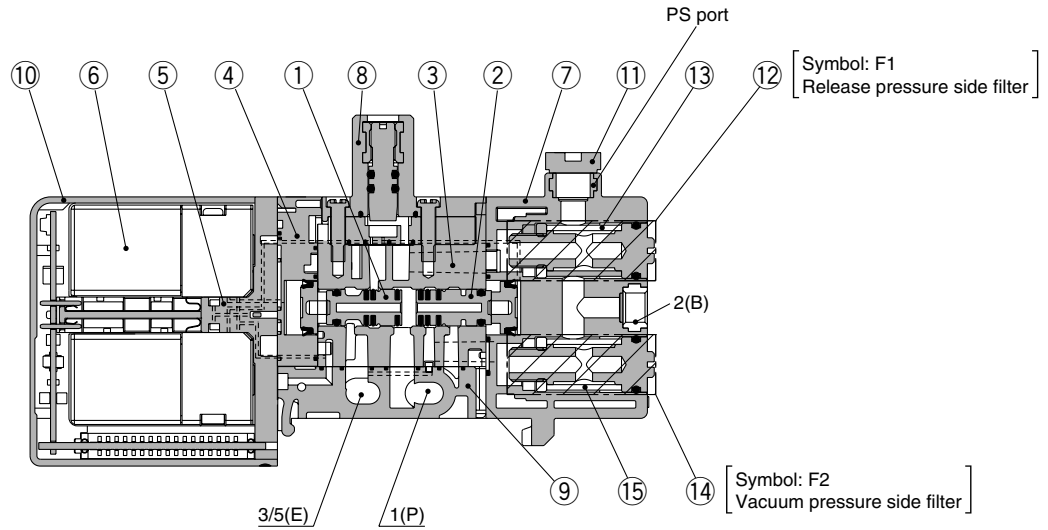

Component Parts

No.	Description	Material	Note
1	Spool valve assembly	Resin/H-NBR	A side (for release pressure switching)
2	Spool valve assembly	Resin/H-NBR	B side (for vacuum pressure switching)
3	Body	Zinc die-cast	—
4	Adaptor plate	Resin	White
5	Pilot adaptor	Resin	White
6	Pilot valve assembly	—	—
7	End cover	Resin	White
8	Restrictor block assembly <small>Note)</small>	Resin	White
9	Bottom cover	Resin	White
10	Light cover	Resin	Light blue

Note) Set the operating torque of the restrictor of the restrictor block assembly to 0.3 N·m or less.

Component Parts

No.	Description	Part no.	Note
11	Plug	M-5P	PS port with plug
12	Filter assembly	SJ3000-110-1A	1 μm White <Release pressure side>
13	Filter	SJ3000-107-1A	1 μm White <Release pressure side>, 5 pcs. included
14	Filter assembly	SJ3000-110-2A	30 μm Light purple <Vacuum pressure side>
15	Filter	SJ3000-107-2A	30 μm Light purple <Vacuum pressure side>, 5 pcs. included

<Filter replacement instructions>

If there are situations such as filter clogging, a drop in suction force, or slow response time, stop operation and replace the filter.

- Using a precision driver, remove the filter assembly (12 or 14) from the main unit.
- Turn the filter guide by hand and remove.
- Replace the filter (13 or 15) and gently hand tighten the filter guide. At this time, check that there is no foreign matter on the O-ring of the filter assembly.
- Return the filter assembly to the main unit.
(Tightening torque: 0.12 N·m)

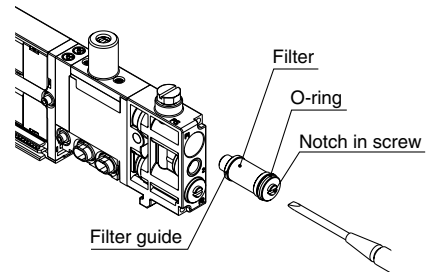

After tightening the plug (M-5P) with a tightening torque of 1 N·m, or manually tightening, use the tightening tool and tighten it by 1/4 turn.

12/14 Filter assembly (with filter)

13/15 Filter (5 pcs. included)

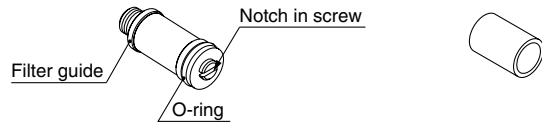

Adsorbing and Transferring System Circuit Example

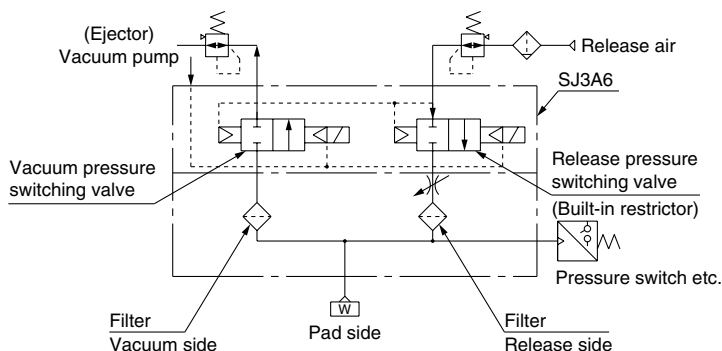

SJ
SY
SV
SYJ
SZ
VP4
S0700
VQ
VQ4
VQ5
VQC
VQZ
SQ
VFS
VFR
VQ7

Plug-in Connector Type

Vacuum Release Valve with Restrictor

Series SJ3A6

An order for a manifold base only is not acceptable. Please order the solenoid valves for mounting at the same time to order the manifold base as in the following "How to Order Manifold Assembly".

How to Order

● Vacuum release valve manifold with restrictor

SS3J3-V60   - **05** **U**  

Vacuum release valve with restrictor type

Connector type

Symbol	Mounting position	Note
FD	D-sub connector	Parallel wiring
PD	Flat ribbon cable 26 pins	
PGD	Flat ribbon cable 20 pins	
PHD	Flat ribbon cable 10 pins	
JD	Flat ribbon cable (PC wiring, without power supply terminal)	Serial wiring
GD	Flat ribbon cable (PC wiring, with power supply terminal)	
S 	EX180 serial transmission	Serial wiring
S6B	EX510 serial transmission	

Note) Refer to pages 26, 42, 50, and 58 for details.

Connector entry

With parallel wiring specifications, it is necessary to select the connector entry direction (1: upward, 2: lateral). (Only upward is available for GD.) For details, refer to pages 26 and 42.

DIN rail length specified

Nil	Standard length	
3	3 stations	Specify a longer rail than the standard length.
⋮	⋮	
16	16 stations	

* Specify the valve stations not exceeding the maximum stations.

SUP/EXH block mounting position

U	U side (2 to 10 stations)
D	D side (2 to 10 stations)
B	Both sides (2 to 16 stations)
M*	Special specifications

* Specify the required specifications (including port sizes other than ø8) by means of the manifold specification sheet.

SUP/EXH block fitting spec.

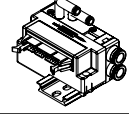
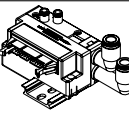
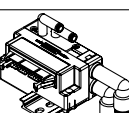
Nil	Straight fitting	
L	Elbow fitting (Upward)	
B	Elbow fitting (Downward)	

* There is no need to enter anything when the SUP/EXH block mounting position "M" is selected. Also, this manifold comes standard with external pilot specifications.

How to Order Valve Manifold Assembly

Ordering example (SS3J3-V60PD2-)

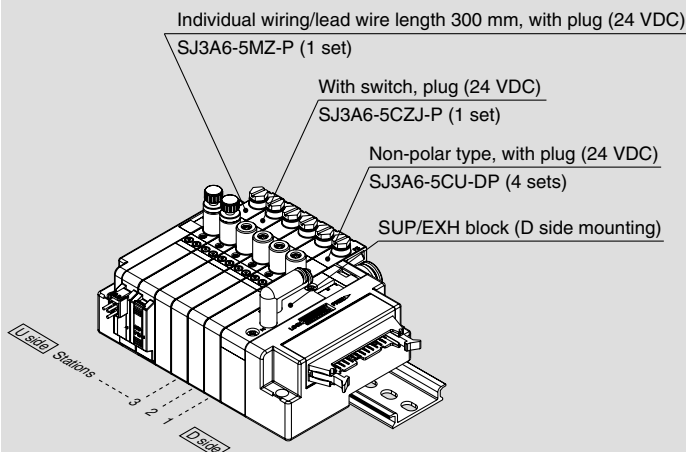

SS3J3-V60PD2-06D 1 set (Manifold part no.)
 * **SJ3A6-5CU-DP** 4 sets (Non-polar type, with plug part no.)
 * **SJ3A6-5CZJ-P** 1 set (With switch, plug part no.)
 * **SJ3A6-5MZ-P** 1 set (Individual wiring, lead wire length 300 mm, with plug part no.)

The asterisk denotes the symbol for assembly. Prefix to the part no. of the solenoid valve, etc.

- The valve arrangement is numbered as the 1st station from D side.
- Indicate the valves to be attached below the manifold part number, in order starting from station 1 as shown in the drawing. In the case of complex arrangement, specify them in the manifold specification sheet.

● Valve stations

F: D-sub connector

Symbol	Stations
02	2 stations
⋮	⋮
12	12 stations

P: Flat ribbon cable (26 pins)

Symbol	Stations
02	2 stations
⋮	⋮
12	12 stations

PG: Flat ribbon cable (20 pins)

Symbol	Stations
02	2 stations
⋮	⋮
09	9 stations

PH: Flat ribbon cable (10 pins)

Symbol	Stations
02	2 stations
⋮	⋮
04	4 stations

J: Flat ribbon cable (PC wiring)

Symbol	Stations
02	2 stations
⋮	⋮
08	8 stations

S6B: EX510 serial transmission

Symbol	Stations
02	2 stations
⋮	⋮
08	8 stations

G: Flat ribbon cable (PC wiring, with power supply terminal)

Symbol	Stations
02	2 stations
⋮	⋮
08	8 stations

S: EX180 serial transmission

Symbol	Stations	Note
02	2 stations	There are limitations on the station number, depending on the serial type. Refer to page 50 for details.
⋮	⋮	
16	16 stations	

* The number of the blanking block assembly is also included. For the blanking block assembly, please select double wiring specifications.

How to Order Solenoid Valves (3 Position 3 Port with Restrictor)

- Standard**
- With switch**
- Individual wiring**
[For plug-in mixed mounting] Note 1)

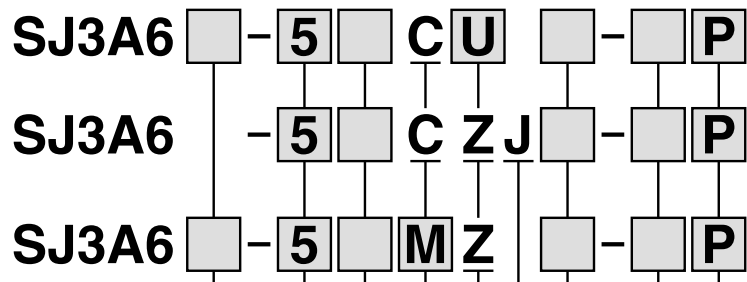

Note 1) Refer to pages 90 and 91 for the dedicated non-plug-in individual wiring.

Coil spec.

Nil	Standard
T	With power saving circuit (Continuous duty type)

* Be sure to select "with power saving circuit" when the solenoid valve will be energized continuously for long period.

Rated voltage

5	24 VDC
6	12 VDC

* Only 24 VDC is available for manifolds compatible with serial wiring and PC wiring.

Common specifications

Nil	+COM.
N	-COM.

* Only +COM. is available for manifolds compatible with EX180 serial wiring and PC wiring.
* For the non-polar type, there is no need to select a symbol.

Connector entry

C: Dedicated for centralized wiring

M: Individual wiring, With lead wire Length 300 mm

With linkage printed circuit board

MN: Individual wiring, Without lead wire (With connector, socket)

With linkage printed circuit board

MO: Individual wiring, Without connector

With linkage printed circuit board

Light/surge voltage suppressor

U	With light/surge voltage suppressor (Non-polar type)
Z	With light/surge voltage suppressor (Polar type)

* When the types with power saving circuit, with switches, and/or individual wiring are used, the non-polar type cannot be selected.

With switch

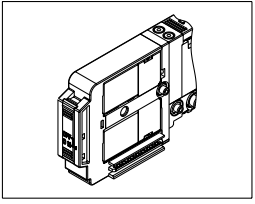

PS port for detection

Nil: M5 x 0.8



P: With plug (M-5P)

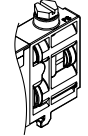

* When mounting a pressure sensor etc., select "Nil."

Needle operation

Nil: Manual



D: Slotted locking type



* Set operation torque to 0.3 N·m or less.

Manual override

Nil: Non-locking push type

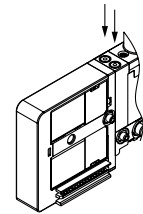

D: Push-turn locking slotted type

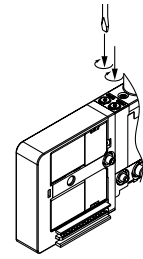

- SJ**
- SY
- SV
- SYJ
- SZ
- VP4
- S0700
- VQ
- VQ4
- VQ5
- VQC
- VQZ
- SQ
- VFS
- VFR
- VQ7

* Connector entries with the symbol "M□" can not use the switch signal from the common wiring on the manifold.
* When ordering a connector assembly separately, refer to page 99.

Note 2) There is no valve block switch for linking the neighboring valve, etc. to the 3 position 3 port solenoid valve with restrictor. Consult SMC if you wish to use the SJ2000/3000 valve with a valve block switch, or an end block or SUP/EXH block assembly.

Series SJ3A6

Dimensions

SS3J3-V60 ^{P□D} 1 ^{JD} 2 - Stations U/D/B

^{FD}
^{S□}
^{S6B}

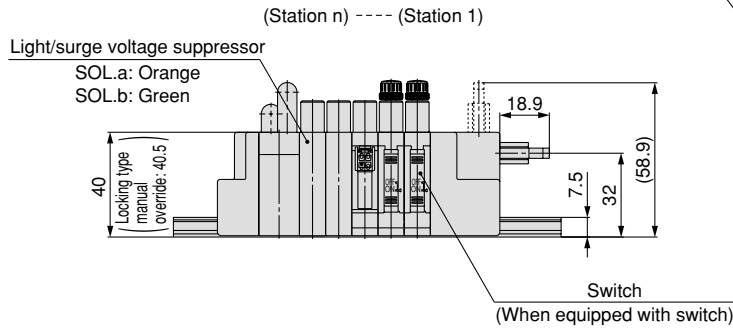
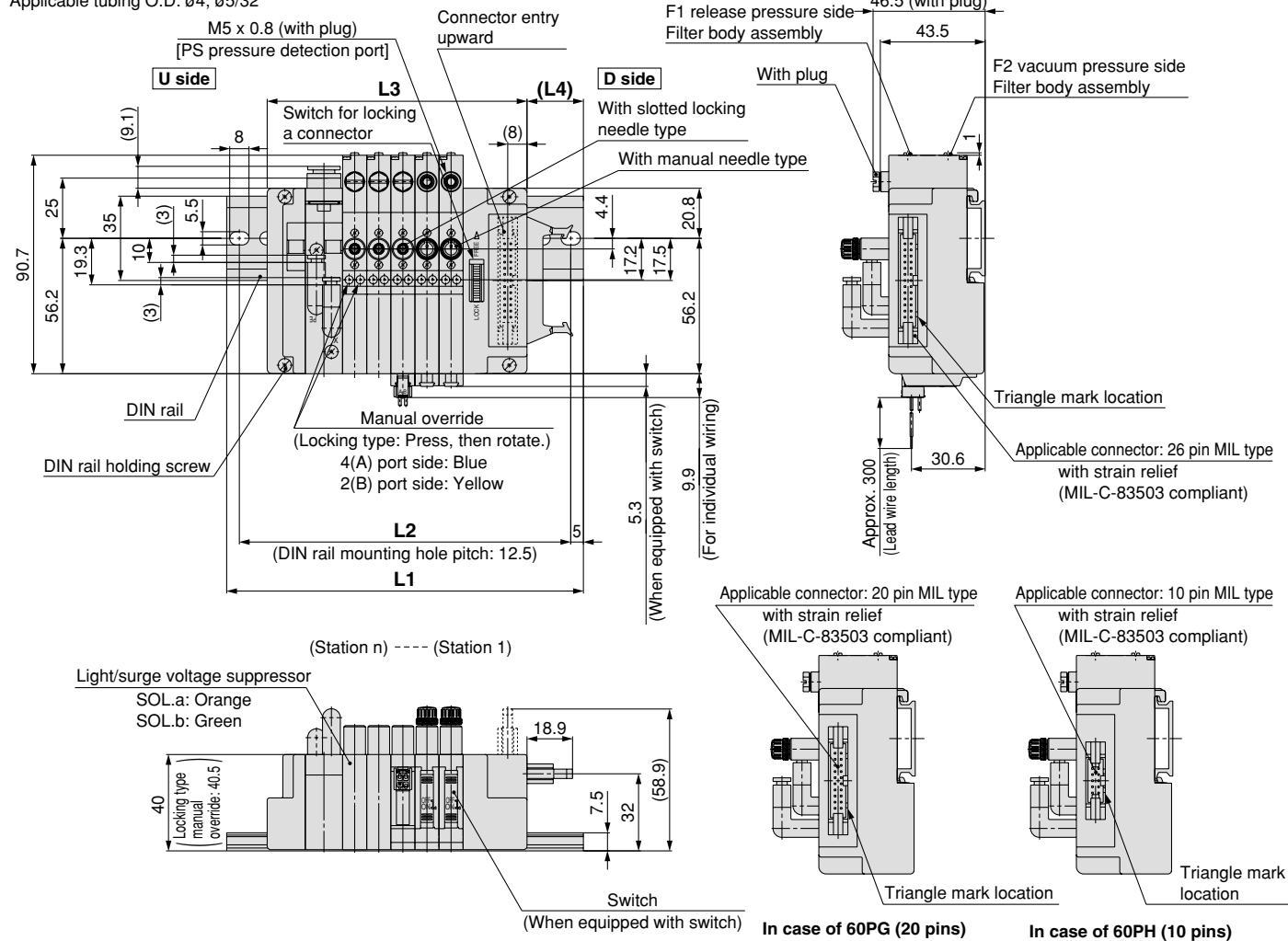
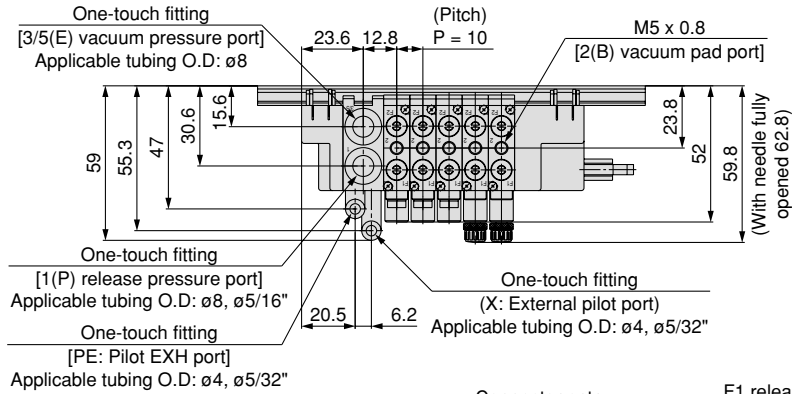

Since DIN rail dimensions are the same as the SS5J3-60□ series, refer to the following pages.

For D-sub connector: Page 31, 32

For flat ribbon cable: Page 36, 37

For EX180 serial wiring: Page 54, 55

For EX510 serial wiring: Page 62, 63

Applicable connector: D-sub (JIS-X-5101, MIL-C-24308) equivalent

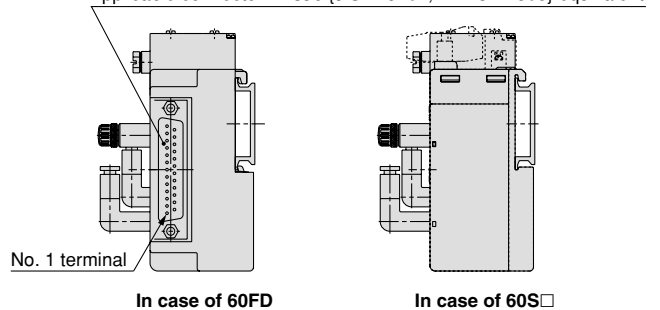

SJ

SY

SV

SYJ

SZ

VP4

S0700

VQ

VQ4

VQ5

VQC

VQZ

SQ

VFS

VFR

VQ7

Non plug-in Individual Wiring

Vacuum Release Valve with Restrictor

Series SJ3A6 [®] US

An order for a manifold base only is not acceptable. Please order the solenoid valves for mounting at the same time to order the manifold base as in the following "How to Order Manifold Assembly".

How to Order

● Individual wiring manifold

SS3J3-V60-05 U

Vacuum release valve with restrictor type •

Valve stations •

Symbol	Stations
02	2 stations
⋮	⋮
20	20 stations

SUP/EXH block mounting position •

U	U side (2 to 10 stations)
D	D side (2 to 10 stations)
B	Both sides (2 to 20 stations)
M*	Special specifications

* Specify the required specifications (Including port sizes other than ø8) by means of the manifold specification sheet.

DIN rail length specified

Nil	Standard length	
3	3 stations	Specify a longer rail than the standard length.
⋮	⋮	
20	20 stations	

* Specify the valve stations not exceeding the maximum stations.

SUP/EXH block fitting spec.

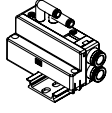
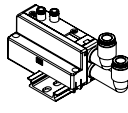
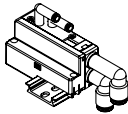
Nil	Straight fitting	
L	Elbow fitting (Upward)	
B	Elbow fitting (Downward)	

How to Order Valve Manifold Assembly

Ordering example (SS3J3-V60-□)

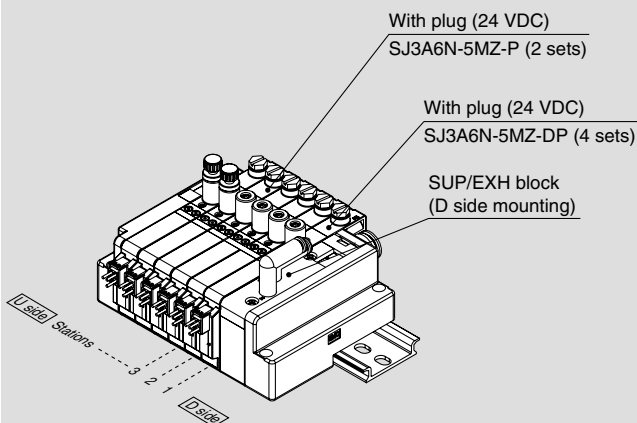

SS3J3-V60-06D 1 set (Manifold part no.)
 * SJ3A6N-5MZ-DP 4 sets (With plug part no.)
 * SJ3A6N-5MZ-P 2 sets (With plug part no.)

→ The asterisk denotes the symbol for assembly. Prefix to the part no. of the solenoid valve, etc.

- The valve arrangement is numbered as the 1st station from D side.
- Indicate the valves to be attached below the manifold part number, in order starting from station 1 as shown in the drawing. In the case of complex arrangement, specify them in the manifold specification sheet.

* There is no need to enter anything when the SUP/EXH block mounting position "M" is selected. Also, this manifold comes standard with external pilot specifications.

How to Order Solenoid Valves (3 Position 3 Port with Restrictor)

SJ3A6 **N**-**5** **MZ** - **P**

Coil spec.

Nil	Standard
T	With power saving circuit (Continuous duty type)

* Be sure to select "with power saving circuit" when the solenoid valve will be energized continuously for long period.

For non-plug-in only

Rated voltage

5	24 VDC
6	12 VDC

Common specifications

Nil	+COM.
N	-COM.

Connector entry

M: Individual wiring, With lead wire
Length 300 mm

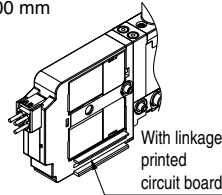

MN: Individual wiring, Without lead wire
(With connector, socket)

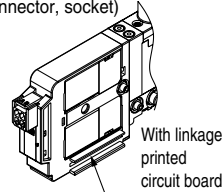

MO: Individual wiring, Without connector

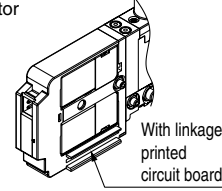

* When ordering a connector assembly separately, refer to page 99.

With light/surge voltage suppressor

PS port for detection

Nil: M5 x 0.8



P: With plug (M-5P)



* When mounting a pressure sensor etc., select "Nil."

Needle operation

Nil: Manual

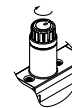

D: Slotted locking type

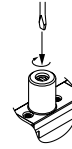

* Set operation torque to 0.3 N·m or less.

Manual override

Nil: Non-locking push type

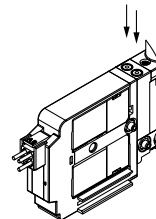

D: Push-turn locking slotted type

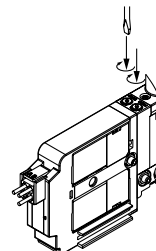

- SJ**
- SY**
- SV**
- SJY**
- SZ**
- VP4**
- S0700**
- VQ**
- VQ4**
- VQ5**
- VQC**
- VQZ**
- SQ**
- VFS**
- VFR**
- VQ7**

Series SJ3A6

Dimensions

SS3J3-V60- Stations U/D/B

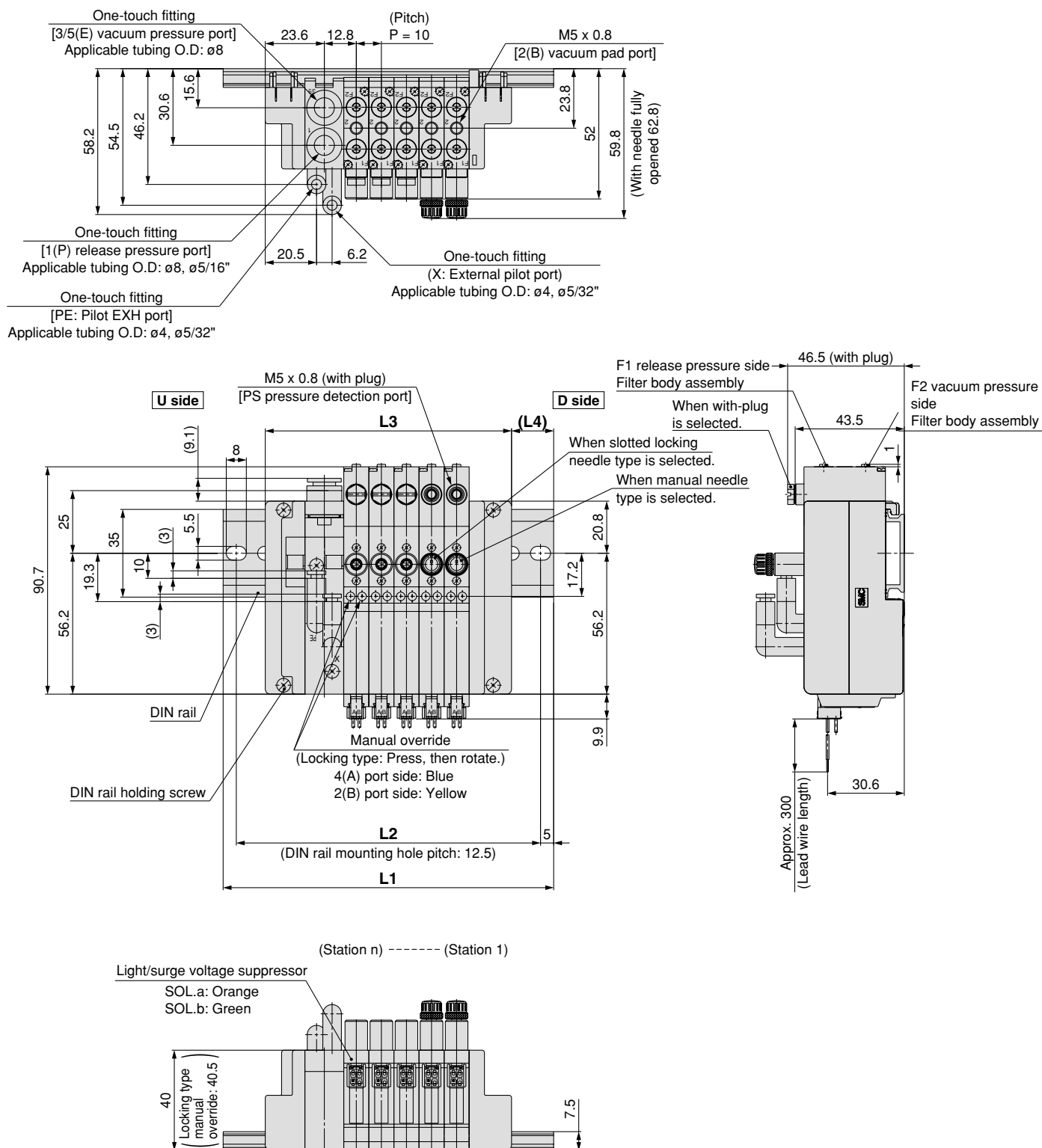

Since DIN rail dimensions are the same as the SS5J3-60-□ series, refer to pages 72 and 73.

Manifold Exploded View

Type V60P (Vacuum release valve with restrictor) manifold

Note) Refer to page 66 for "How to Add Manifold Stations."

Type V60S (Plug-in, EX180 Integrated type (for output serial transmission system) manifold

Type V60G (Plug-in, PC wiring with power supply terminal) manifold

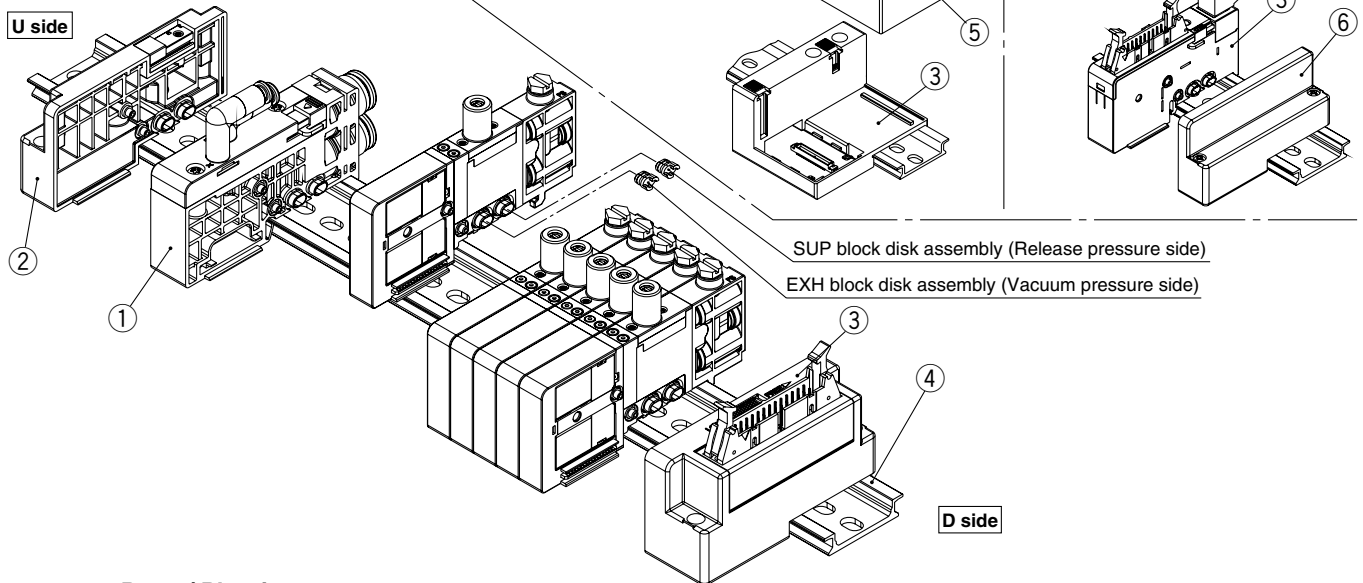

Component Parts / Plug-in

No.	Description	Part no.	Note
1 Note 1)	SUP/EXH block assembly	External pilot specification SJ3000-50-1AR-□□-N (X, PE port: Metric size ø4 Inch size ø5/32")	(Metric size) C6: With ø6 One-touch fitting (straight) C8: With ø8 One-touch fitting (straight) L6: With ø6 One-touch fitting (elbow upward entry) L8: With ø8 One-touch fitting (elbow upward entry) B6: With ø6 One-touch fitting (elbow downward entry) B8: With ø8 One-touch fitting (elbow downward entry)
		For different pressures Note 2) SJ3000-50-3A-□□-N	(Inch size) N7: With 1/4" One-touch fitting (straight) N9: With 5/16" One-touch fitting (straight)
2 Note 1)	End block assembly	SJ3000-53-1A-N	For U side
3	Connector block assembly	SJ3000-42-□A-□ SJ3000-76-2A-05	Refer to the connector block assembly part no. shown below.
4	DIN rail	VZ1000-11-1-□	Refer to page 77.
5	SI unit	EX180-□□	Refer to the SI unit part numbers on page 50.
6	End block assembly	SJ3000-53-2A	For D side

Connector Block Assembly Part No.

Connector specifications	Mounting position	Part no.	Note
For D-sub connector	D side	SJ3000-42-1A-□	□: 1 (Connector upward) □: 2 (Connector lateral)
For flat ribbon cable 26 pins		SJ3000-42-2A-□	
For flat ribbon cable 20 pins		SJ3000-42-3A-□	
For flat ribbon cable 10 pins		SJ3000-42-4A-□	
For PC wiring 20 pins		SJ3000-42-6A-□	
For EX180 serial wiring Note)		SJ3000-42-20A	
For EX510 serial wiring Note)		SJ3000-42-3A-2	
For PC wiring 20 pins with power supply terminal		SJ3000-76-2A-05	

Note) SI unit is not included.

Component Parts / Non-plug-in

No.	Description	Part no.	Note
1 Note 1)	SUP/EXH block assembly	External pilot specification SJ3000-50-5AR-□□-N (X, PE port: Metric size ø4 Inch size ø5/32")	(Metric size) C6: With ø6 One-touch fitting (straight) C8: With ø8 One-touch fitting (straight) L6: With ø6 One-touch fitting (elbow upward entry) L8: With ø8 One-touch fitting (elbow upward entry) B6: With ø6 One-touch fitting (elbow downward entry) B8: With ø8 One-touch fitting (elbow downward entry)
		For different pressures Note 2) SJ3000-50-6A-□□-N	(Inch size) N7: With 1/4" One-touch fitting (straight) N9: With 5/16" One-touch fitting (straight)
2 Note 1)	End block assembly	SJ3000-53-1A-N	For U side
4	DIN rail	VZ1000-11-1-□	Refer to page 77.
6	End block assembly	SJ3000-53-2A	For D side

Note 1) For the SJ3A6 series, valve block and manual switches are not available.

Note 2) The valves cannot be operated only with the SUP/EXH block assembly for different pressure, select in combination with the SUP/EXH block assembly for external pilot.

Note 3) Refer to page 76 about the SUP/EXH block disk assembly and method of handling of parts at different pressure.

SJ
SY
SV
SYJ
SZ
VP4
S0700
VQ
VQ4
VQ5
VQC
VQZ
SQ
VFS
VFR
VQ7



Series SJ2000/3000

Specific Product Precautions 1

Be sure to read before handling.

Refer to front matters 58 and 59 for Safety Instructions and pages 3 to 7 for 3/4/5 Port Solenoid Valve Precautions.

Manual Override Switch Operation

Warning

For manual override operation, move the manual override switch to a position where letters A and B can be seen. [Manual override switch release status (refer to the figure below)] Operation with the manual override switch in a locked status can cause damage to the manual override and air leakage, so be sure to release the manual override switch before use. After manual override operation, lock the manual switch for use (when the manual override of the push-turn locking slotted type is locked, a manual override switch cannot be locked).

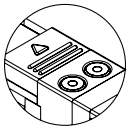

Manual override switch locked status

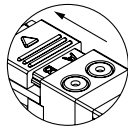

Manual override switch unlocked status

Manual override switch slide direction

Manual Override Operation

Warning

When the manual override is operated, connected equipment will be actuated. Confirm safety before operating.

Non-locking push type

Press in the direction of the arrow.

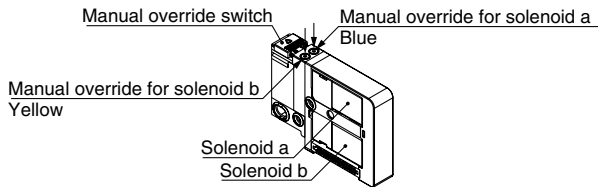

Push-turn locking slotted type

While pressing, turn in the direction of the arrow (90° clockwise). If it is not turned, it can be used in the same way as the non-locking push type.

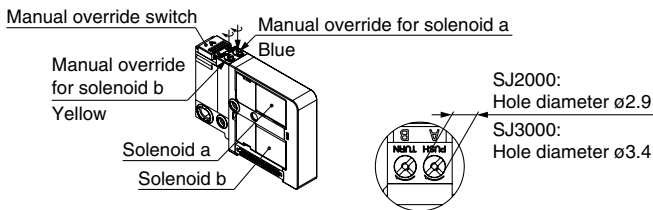

Enlarged view of manual override part

Caution

When you operate the D type with a screwdriver, turn it gently using a watchmaker's screwdriver. [Torque: under 0.05 N·m] When you lock the manual override of the D type, be sure to push it before turning. [Load: 10 N or less] Turning without pushing can cause damage to the manual override and trouble such as air leakage, etc.

Valve with Switch

Warning

When turning OFF the valve using the switch, move it to the position where the valve is locked. If the switch is at an improper position and is energized, equipment connected to the valve could be actuated.

Also, if the switch is turned OFF on the valve in the energized state, be careful because any actuators connected to a single solenoid, a dual 3 port valve or a 3 position valve will actuate.

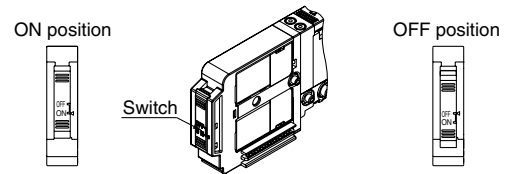

Normal operation: The valve is switched according to electric signals from the connector on the manifold side.

The valve coil is kept in a deenergized state even when there is an electric signal from the connector on the manifold side.

Electric circuit diagram (with positive common and light/surge voltage suppressor)

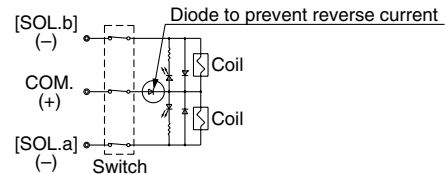

Built-in Back Pressure Check Valve Type

Caution

Valves with built-in back pressure check valve is to protect the back pressure inside a valve. For this reason, use caution the valves with external pilot specification cannot be pressurized from exhaust port [3/5(E)].

As compared with the types which do not integrate the back pressure check valve, C value of the flow characteristics goes down. For details, please contact SMC.

Exhaust Restriction

Caution

Since the SJ series is a type in which the pilot valve exhaust joins the main valve exhaust inside the valve, use caution, so that the piping from the exhaust port is not restricted.



Series SJ2000/3000

Specific Product Precautions 2

Be sure to read before handling.

Refer to front matters 58 and 59 for Safety Instructions and pages 3 to 7 for 3/4/5 Port Solenoid Valve Precautions.

When Using a 4 Port Valve as a 3 Port Valve

Caution

When using a 4 port valve as a 3 port valve

The SJ2000/3000 series can be used as normally closed (N.C.) or normally open (N.O.) 3 port valves by plugging one of the cylinder ports 4(A) or 2(B). However, exhaust ports should be left open. It is convenient when a double solenoid 3 port valve is required.

Plug position	2(B) port	4(A) port
Type of actuation	N.C.	N.O.
Number of solenoids	Single 	Single
	Double 	Double

Light/surge Voltage Suppressor

Caution

Non-polar type

Single solenoid

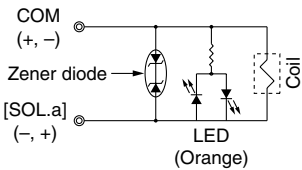

Double solenoid, 3 position type

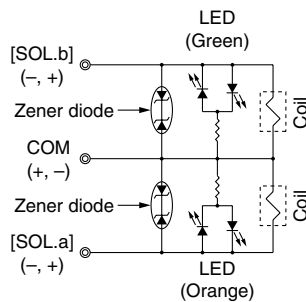

Polar type

Single solenoid

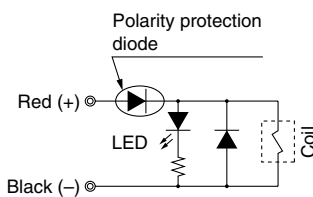

Double solenoid, 3 position type

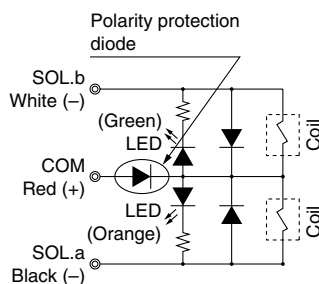

Continuous Duty

Caution

If a valve is energized continuously for a long time, the rise in temperature due to heat-up of the coil may cause a decline in solenoid valve performance, reduce service life, or have adverse effects on peripheral equipment. If a valve will be energized continuously, please be sure to use the "Continuous duty type" with a power saving circuit. In particular, there will be a large increase in temperature if 3 or more neighboring stations are simultaneously energized for a long time, or if the A and B sides are simultaneously continuously energized for a long time in a dual 3 port valve. Please be very careful in such cases.

With power saving circuit

Compared to the standard products, power consumption is reduced down to approx. 1/3 (in case of SJ3□60T) by cutting the unnecessary wattage required to hold the valve in an energized state. (Effective energizing time is over 67 ms at 24 VDC.)

Electric circuit diagram (with power saving circuit) In case of single solenoid

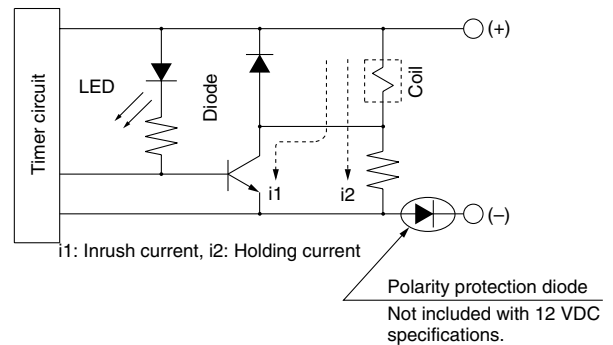

- SJ
- SY
- SV
- SJY
- SZ
- VP4
- S0700
- VQ
- VQ4
- VQ5
- VQC
- VQZ
- SQ
- VFS
- VFR
- VQ7



Series SJ2000/3000 Specific Product Precautions 3

Be sure to read before handling.

Refer to front matters 58 and 59 for Safety Instructions and pages 3 to 7 for 3/4/5 Port Solenoid Valve Precautions.

Working Principle

With the circuit of page 95, the current consumption, when holding, is reduced to save energy. Please refer to the electric wave data below.

In case of SJ3□60T, electric waveform of energy saving type

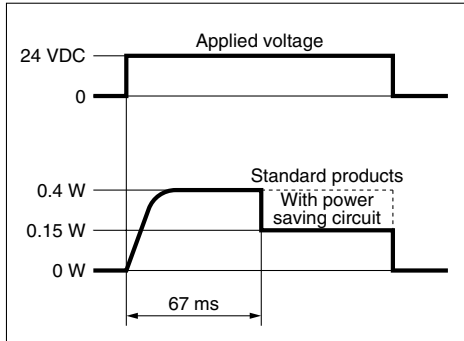

- When a power saving circuit is installed, a diode to prevent reverse current is not available for 12 V DC spec. Therefore, use caution not to connect in reverse.
- Be careful about the allowable voltage fluctuation since a voltage drop of about 0.5 V occurs due to a transistor. (Refer to the solenoid specifications of each valve for details.)

Measures to prevent detours of surge voltage

When the DC power supply is shut off, by the emergency breaking circuit for example, valve misoperation may occur due to surge voltage produced by other electrical parts (such as electromagnetic coils). Please take measures to prevent surges from detouring to the valve (surge protection diode etc.), or use a valve with diode to prevent reverse current (polar: Z type). However, surge countermeasures are provided on the serial unit side of the serial type.

Circuit example

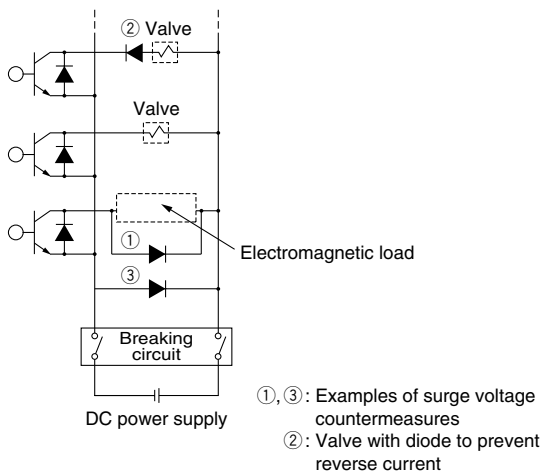

- ①, ③: Examples of surge voltage countermeasures
②: Valve with diode to prevent reverse current

Light Indication

Caution

When equipped with light/surge voltage suppressor, the light window turns orange when solenoid a is energized, and it turns green when solenoid b is energized.

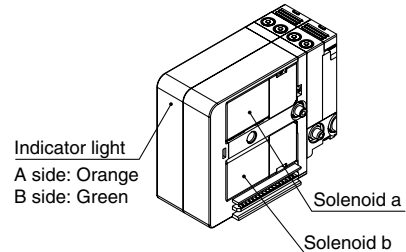

Changing the Connector Entry Direction

Caution

To change the connector's entry direction, set the switch on the top of the connector block to the FREE position, before turning the connector. Make sure to set the switch back to the LOCK position before connecting the connector. (When the switch is difficult to slide, move the connector a little so that it will slide easier.)

If an excessive force is applied on the connector in the LOCK position, the connector block may be damaged. Also, using in such a way that the connector floats in the FREE position, it may cause the lead wire, etc. to break. Thus, refrain from using in these ways.

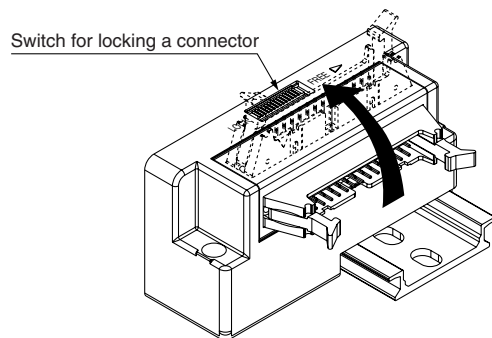

Manifold Mounting

When attaching a manifold to a mounting surface, etc., with bolts, if the entire bottom surface of the DIN rail contacts the mounting surface in a horizontal mounting, it can be used by simply securing both ends of the DIN rail. However, for any other mounting method or for side facing and rear facing, etc., secure the DIN rail with bolts at uniform intervals using the following as a guide: 2 to 5 stations at 2 locations, 6 to 10 stations at 3 locations, 11 to 15 stations at 4 locations, 16 to 20 stations at 5 locations, 21 to 25 stations at 6 locations, 26 to 30 stations at 7 locations and more than 30 stations at 8 locations.

In addition, even in the case of a horizontal mounting, if the mounting surface is subject to vibration, etc., take the same measures indicated above. If secured at fewer than the specified number of locations, warping or twisting may occur in the DIN rail and manifold, causing trouble such as air leakage.



Series SJ2000/3000 Specific Product Precautions 4

Be sure to read before handling.

Refer to front matters 58 and 59 for Safety Instructions and pages 3 to 7 for 3/4/5 Port Solenoid Valve Precautions.

Fitting Assembly Replacement

Caution

By replacing a valve's fitting assembly, it is possible to change the port size of the 4(A), 2(B), 1(P), and 3/5(E) ports. When replacing it, pull out the fitting assembly after removing the clip with a flat head screwdriver, etc. To mount a new fitting assembly, insert it into place and then fully reinsert the clip.

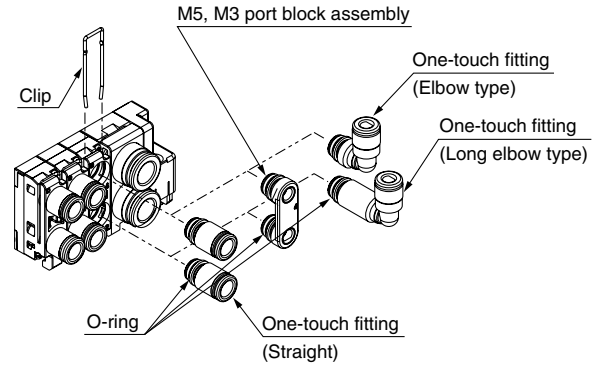

Fitting Assembly Part No.

Metric Size

Port	Port size	Part no.
SJ2000 4(A) 2(B)	ø2 one-touch fitting assembly (Straight)	KJH02-C1
	ø4 one-touch fitting assembly (Straight)	KJH04-C1
	ø2 one-touch fitting assembly (Elbow type)	KJL02-C1
	ø4 one-touch fitting assembly (Elbow type)	KJL04-C1-N
	ø2 one-touch fitting assembly (Long elbow type)	KJW02-C1
	ø4 one-touch fitting assembly (Long elbow type)	KJW04-C1-N
	M3 port block assembly	SJ2000-56-1A
SJ3000 4(A) 2(B)	ø2 one-touch fitting assembly (Straight)	KJH02-C2
	ø4 one-touch fitting assembly (Straight)	KJH04-C2
	ø6 one-touch fitting assembly (Straight)	KJH06-C2
	ø2 one-touch fitting assembly (Elbow type)	KJL02-C2
	ø4 one-touch fitting assembly (Elbow type)	KJL04-C2
	ø6 one-touch fitting assembly (Elbow type)	KJL06-C2-N
	ø2 one-touch fitting assembly (Long elbow type)	KJW02-C2
	ø4 one-touch fitting assembly (Long elbow type)	KJW04-C2
	ø6 one-touch fitting assembly (Long elbow type)	KJW06-C2-N
	M5 port block assembly	SJ3000-56-1A
1(P) 3/5(E)	ø6 one-touch fitting assembly (Straight)	VVQ1000-51A-C6
	ø6 one-touch fitting assembly (Elbow type)	SZ3000-74-1A-L6
	ø6 one-touch fitting assembly (Long elbow type)	SZ3000-74-2A-L6
	ø8 one-touch fitting assembly (Straight)	VVQ1000-51A-C8
	ø8 one-touch fitting assembly (Long elbow type)	SZ3000-74-2A-L8

Inch Size

Port	Port size	Part no.
SJ2000 4(A) 2(B)	ø1/8" one-touch fitting assembly (Straight)	KJH01-C1
	ø5/32" one-touch fitting assembly (Straight)	KJH03-C1
	ø1/8" one-touch fitting assembly (Elbow type)	KJL01-C1
	ø5/32" one-touch fitting assembly (Elbow type)	KJL03-C1
	ø1/8" one-touch fitting assembly (Long elbow type)	KJW01-C1
	ø5/32" one-touch fitting assembly (Long elbow type)	KJW03-C1
SJ3000 4(A) 2(B)	ø1/8" one-touch fitting assembly (Straight)	KJH01-C2
	ø5/32" one-touch fitting assembly (Straight)	KJH03-C2
	ø1/4" one-touch fitting assembly (Straight)	KJH07-C2
	ø1/8" one-touch fitting assembly (Elbow type)	KJL01-C2
	ø5/32" one-touch fitting assembly (Elbow type)	KJL03-C2
	ø1/4" one-touch fitting assembly (Elbow type)	KJL07-C2
	ø1/8" one-touch fitting assembly (Long elbow type)	KJW01-C2
	ø5/32" one-touch fitting assembly (Long elbow type)	KJW03-C2
1(P) 3/5(E)	ø1/4" one-touch fitting assembly (Straight)	VVQ1000-51A-N7
	ø5/16" one-touch fitting assembly (Straight)	VVQ1000-51A-N9

Note 1) To change the port size of the 1(P), 3/5(E) ports into the port sizes other than ø8 (straight), specify the change by means of the manifold specification sheet.

Note 2) Be careful to avoid damage or contamination to the O-rings, as this can cause air leakage.

Note 3) When removing a straight-type fitting assembly from a valve, after removing the clip, attach tubing or a plug (KJP-02, KQ2P-□□) to the one-touch fitting, and pull it out while holding the tubing or plug. If it is pulled out while holding the release button of the fitting assembly (resin part), the release button may be damaged.

Note 4) Be sure to turn off the power and stop the supply of air before disassembly. Furthermore, since air may remain inside the actuator, piping and manifold, confirm that the air is completely exhausted before starting any work.

Note 5) While inserting a tubing into an elbow-type fitting assembly, hold the main body of the assembly by hand. Failure to do so will exert an undue force on the valve or the fitting assembly, resulting in air leakage or damage.

- SJ
- SY
- SV
- SYJ
- SZ
- VP4
- S0700
- VQ
- VQ4
- VQ5
- VQC
- VQZ
- SQ
- VFS
- VFR
- VQ7



Series SJ2000/3000

Specific Product Precautions 5

Be sure to read before handling.

Refer to front matters 58 and 59 for Safety Instructions and pages 3 to 7 for 3/4/5 Port Solenoid Valve Precautions.

One-touch Fittings

⚠ Caution

The pitch of the SJ series piping ports (A, B etc.) has been set assuming the use of KJ series one-touch fittings. Therefore, when using fittings with an M3 or M5 port block assembly, there may be some interference between fittings, depending on the type and size, so please use after checking dimensions in the catalog for the pipe fitting being used.

1. Tube attachment/detachment for one-touch fittings

1) Attaching of tubing

- (1) Take a tube having no flaws on its periphery and cut it off at a right angle. When cutting the tube, use tube cutters TK-1, 2 or 3. Do not use pinchers, nippers or scissors, etc. If cutting is done with tools other than tube cutters, there is the danger that the tube may be cut diagonally or become flattened, etc., making a secure installation impossible, and causing problems such as the tube pulling out after installation or air leakage. Also allow some extra length in the tube.

- (2) Grasp the tube and push it in slowly, inserting it securely all the way into the fitting.

- (3) After inserting the tube, pull on it lightly to confirm that it will not come out. If it is not installed securely all the way into the fitting, this can cause problems such as air leakage or the tube pulling out.

2) Detaching of tubing

- (1) The 4(A) and 2(B) ports use the KJ series, so the tube can be removed by pressing on part of the release bush. However, for the 1(P) and 3/5(E) ports, please press the release bush evenly as before.

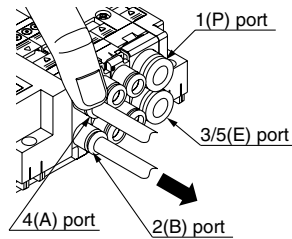

Hold down part of the release bush with your finger or a similar tool, as shown in the diagram, and pull out in the direction indicated by the arrow.

- (2) Pull out the tube while holding down the release button so that it does not come out. If the release button is not pressed down sufficiently, there will be increased bite on the tube and it will become more difficult to pull it out.

- (3) When the removed tube is to be used again, cut off the portion which has been chewed before reusing it. If the chewed portion of the tube is used as is, this can cause trouble such as air leakage or difficulty in removing the tube.

Other Tubing Brands

⚠ Caution

1. When using tube other than SMC brand, confirm the following specifications are satisfied with respect to the outside diameter tolerance of the tube.

- 1) Nylon tubing within ± 0.1 mm
- 2) Soft nylon tubing within ± 0.1 mm
- 3) Polyurethane tubing within $+0.15$ mm, within -0.2 mm

Do not use tubing which does not meet these outside diameter tolerances. It may not be possible to connect them, or they may cause other troubles, such as air leakage or the tube pulling out after connection.

How to Use Plug Connector

⚠ Caution

When attaching and detaching a connector, first shut off the electric power and the air supply.

Also, crimp the lead wires and sockets securely.

1. Attaching and detaching connectors

- To attach a connector, hold the lever and connector unit between your fingers and insert straight onto the pins of the solenoid valve so that the lever's pawl is pushed into the groove and locks.
- To detach a connector, remove the pawl from the groove by pushing the lever downward with your thumb, and pull the connector straight out.

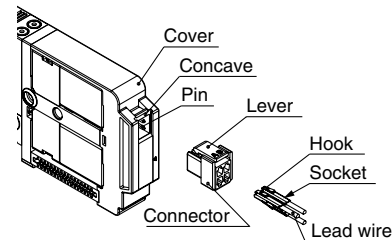

2. Crimping of lead wires and sockets

Peel 3.2 to 3.7 mm of the tip of lead wire, enter the core wires neatly into a socket and crimp it with a special crimp tool. Be careful so that the cover of lead wire does not enter into the crimping part. (Crimping tool: Model no. DXT170-75-1)

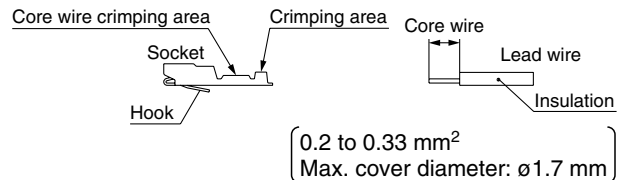

3. Attaching and detaching lead wires with sockets

• Attaching

Insert the sockets into the square holes of the connector (with A, B, C, and N indication), and continue to push the sockets all the way in until the lock by hooking into the seats in the connector. (When they are pushed in, their hooks open and they are locked automatically.) Next, confirm that they are locked by pulling lightly on the lead wires.

• Detaching

To detach a socket from a connector, pull out the lead wire while pressing the socket's hook with a stick having a thin tip (approx. 1 mm). If the socket is used again, spread the hook outward.

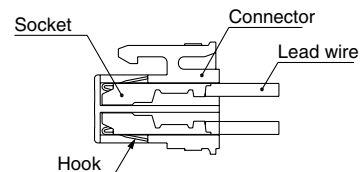

Single solenoid

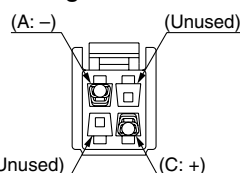

Double solenoid

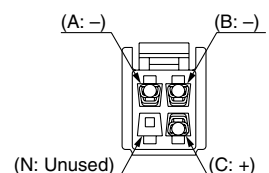



Series SJ2000/3000 Specific Product Precautions 6

Be sure to read before handling.

Refer to front matters 58 and 59 for Safety Instructions and pages 3 to 7 for 3/4/5 Port Solenoid Valve Precautions.

Plug Connector Lead Wire Length

Caution

Plug connector lead wires have a standard length of 300 mm, however, the following lengths are also available.

Connector Assembly Part No. (for Junction Common)

Single solenoid
SJ3000-46-S-□



Double solenoid,
3 position type, 4 position type
SJ3000-46-D-□

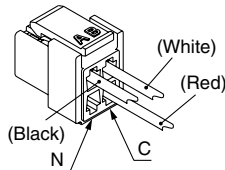
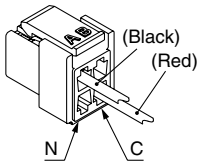
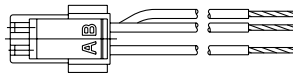

For single solenoid: SJ3000-46-S-□

Lead wire length	
Nil	300 mm
6	600 mm

For double solenoid
For 3 position type : SJ3000-46-D-□
For 4 position type

10	1000 mm
15	1500 mm
20	2000 mm
25	2500 mm
30	3000 mm
50	5000 mm

For single solenoid
Without lead wire : SJ3000-46-S-N
(Connector, Socket x 2 pcs. only)

For double solenoid
Without lead wire : SJ3000-46-D-N
(Connector, Socket x 3 pcs. only)

How to Order

Include the connector assembly part number together with the part number for the plug connector's solenoid valve without connector.

(Example) Lead wire length 2000 mm
SJ3160-5MOZ-C6
SJ3000-46-S-20

Connector Assembly for Manifolds (for Junction Common)

Caution

Using the connector assembly (for junction common) for solenoid valves installed in the manifold reduces the labor involved in wiring work because common wiring for all solenoid valves is integrated into a single wire.

Connector Assembly Part No. (for Junction Common)

Single solenoid
SJ3000-46-SC-□

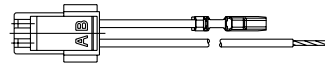

Double solenoid,
3 position type, 4 position type
SJ3000-46-DC-□

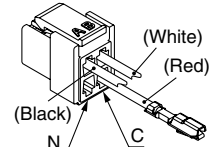
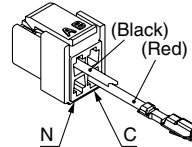
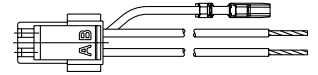

For single solenoid: SJ3000-46-SC-□

For double solenoid
For 3 position type : SJ3000-46-DC-□
For 4 position type

For junction common

Lead wire length	
Nil	300 mm
6	600 mm
10	1000 mm
15	1500 mm
20	2000 mm
25	2500 mm
30	3000 mm
50	5000 mm

How to Order

Indicate the part no. of the connector assembly for the manifold and solenoid valve.

If the arrangement is complicated, please specify them by means of the manifold specification sheet.

Note 1) Applications like connectors not wired to a valve is not possible.
Note 2) For the solenoid valve, please designate "No connector (MOZ)" for the connector type.

Note 3) Connector assembly with lead wire for place where the signals are transmitted to the common wiring. (Only the valves of first station and/or last station of manifold are compatible to connector with lead wire for common.)

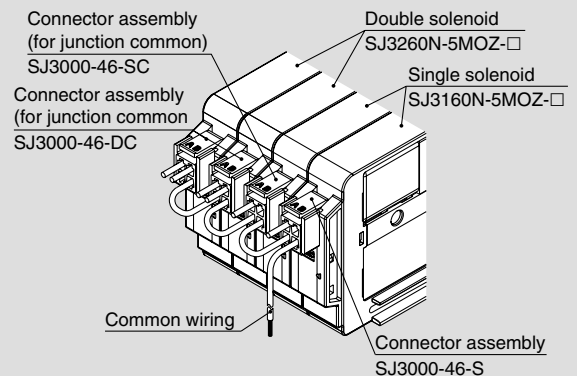

(Example)

SS5J3-60-04U 1 set
* SJ3160N-5MOZ 2 sets
* SJ3260N-5MOZ 2 sets
* SJ3000-46-S 1 set (Connector assembly for single solenoid)
* SJ3000-46-SC 1 set (Connector assembly for single solenoid (for junction common))
* SJ3000-46-DC 2 sets (Connector assembly for double solenoid (for junction common))

→ The asterisk denotes the symbol for assembly. Prefix it to the part nos. of the solenoid valve, etc.

SJ

SY

SV

SJY

SZ

VP4

S0700

VQ

VQ4

VQ5

VQC

VQZ

SQ

VFS

VFR

VQ7



Series SJ2000/3000 Specific Product Precautions 7

Be sure to read before handling.

Refer to front matters 58 and 59 for Safety Instructions and pages 3 to 7 for 3/4/5 Port Solenoid Valve Precautions.

Wiring Instructions for Connector Assembly (for Junction Common)

⚠ Caution

If only connector assembly (for junction common) is ordered, please wire according to the instructions in the diagram below. For details on socket mounting, please refer to "How to Use Plug Connector" on page 98.

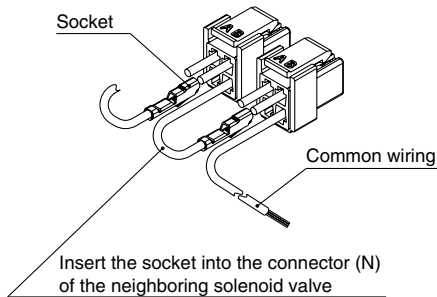

How to Wire to PC Wiring System Compliant Power Supply Terminal

⚠ Caution

Wire connection instructions

1. Strip 6.5 to 7.5 mm from the tip of the lead wire.
2. Loosen the terminal screws (slotted screws) of the power supply terminal connectors, plug the core wire of the lead wire into the square holes of the connector, tighten terminal screws at the proper torque, and fasten them securely. (Gently pull the lead wire and check that it is fastened.)

Precautions

- To remove the power supply terminal connector, pull it upward as is. When mounting, push it in until it makes a snapping noise.
- When connecting wire, be careful because using lead wire that is outside of compatible lead wire ranges, or that are tightened to anything other than the proper torque, creates a risk of defective contact and other problems.

