

# ISO Cylinder ISO Standard (15552)

**New**

ø32, ø40, ø50, ø63, ø80, ø100

### New series added

- Standard type, Double rod: Series C96-W
- Non-rotating rod type, Single rod: Series C96K  
Double rod: Series C96K-W
- Smooth Cylinder: Series C96Y

### Made to Order added

- Heat resistant cylinder (-XB6)
- With heavy duty scraper (-XC4)
- With coil scraper (-XC35) etc. are added.

**Lightweight** Up to **17% Weight reduced**

\* Compared with the current C96 series (ø40, 100 stroke)

■ By adopting a new cushion method (**Air cushion** + **Bumper cushion**),

## Cycle time shortened

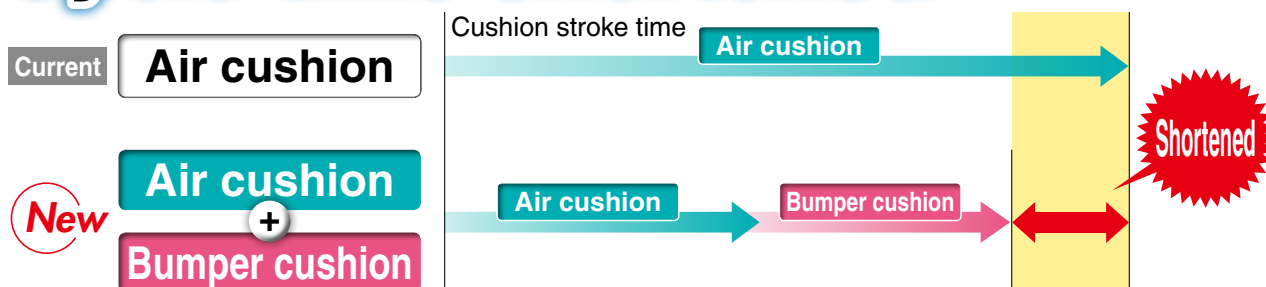

■ Bumper cushion reduces the metal noise that occurs when piston stops

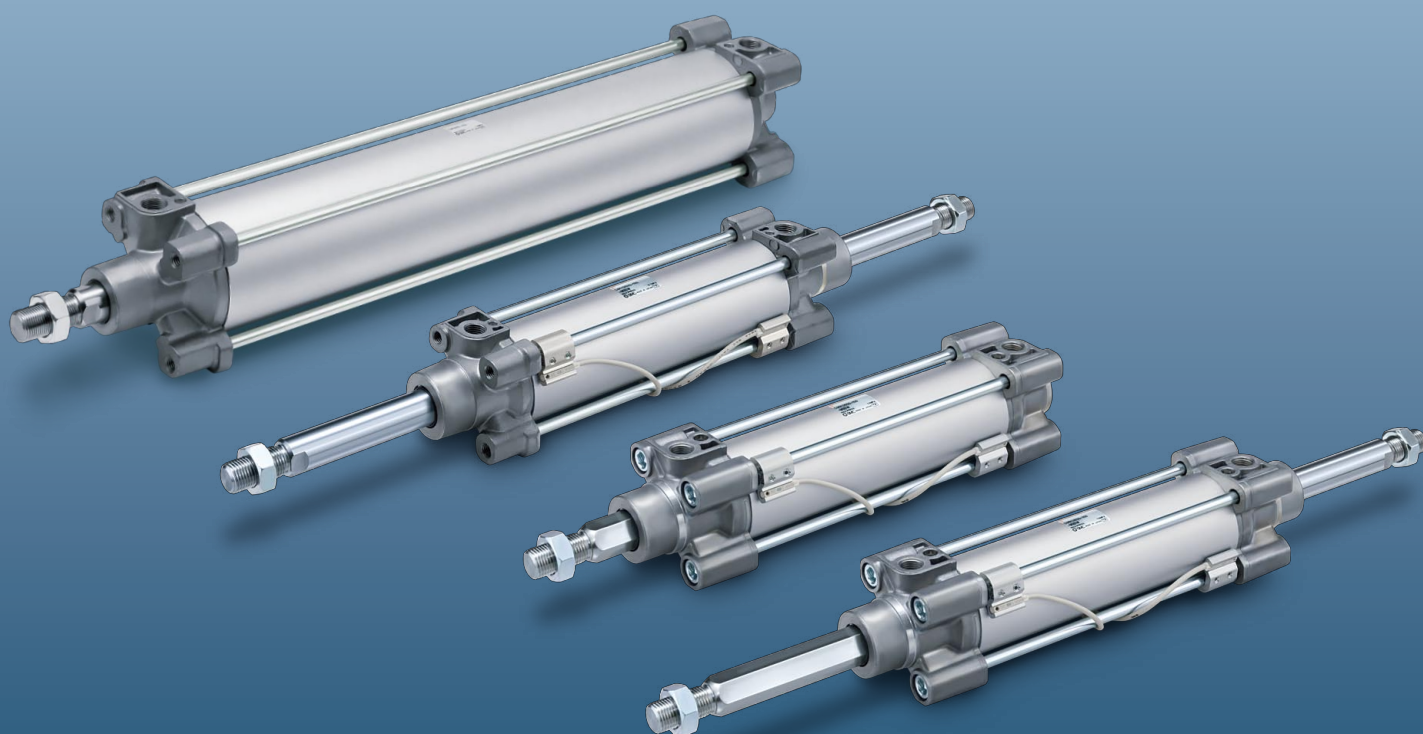

## Series C96



CAT.ES20-242B

# New Series C96

## Weight reduced

Achieved weight reduction by changing rod cover shape and piston structure

Bore size [mm]	C96	Reduction rate
32	0.65	13%
40	0.96	17%
50	1.57	13%
63	1.94	14%
80	3.12	13%
100	4.03	12%

\* Compared with the current C96 series (ø40, 100 stroke)

## Air cushion + Bumper cushion Combined structure

- The cushion stroke time can now be reduced with the double cushioning, which improves the cycle time.
- The bumper cushion reduces the metal noise that occurs when the piston stops at the end of the stroke.

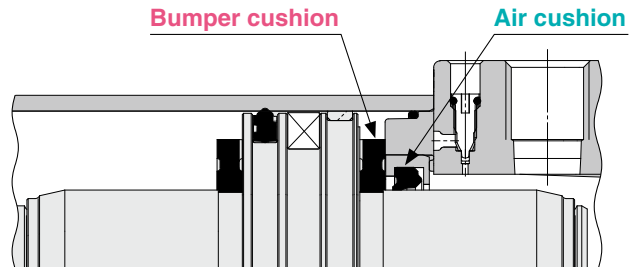

Rod end nut can be screwed up to TRP.

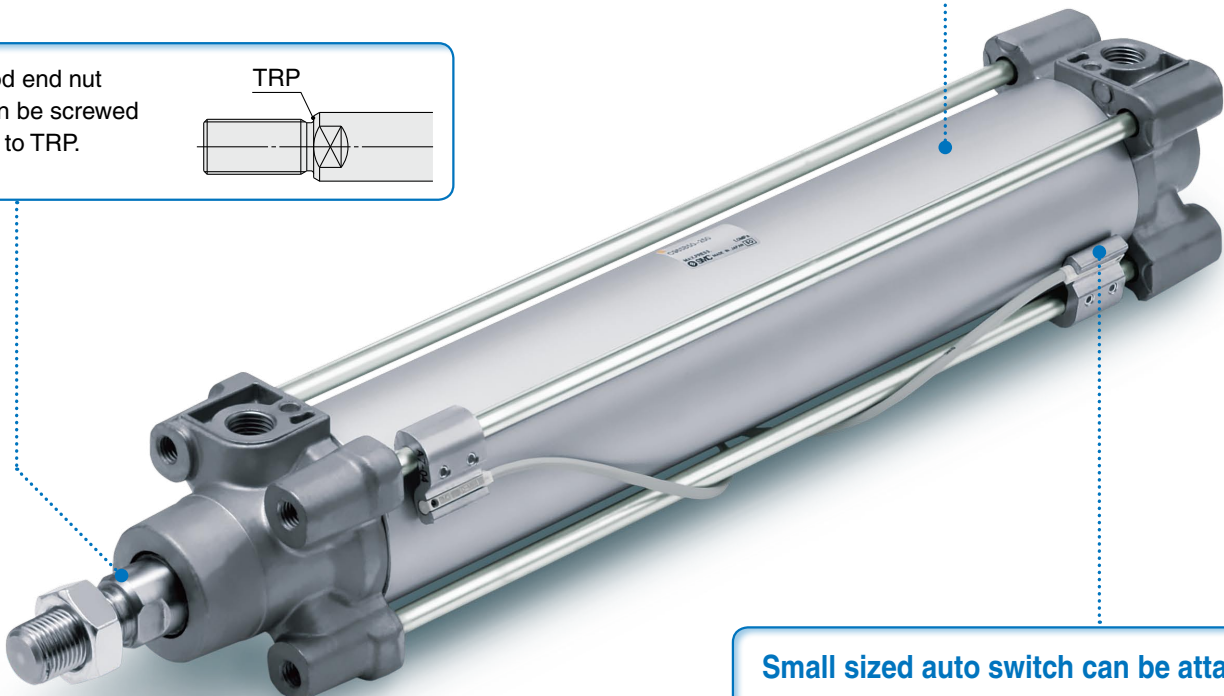
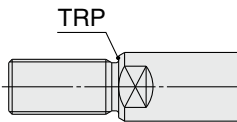

## Small sized auto switch can be attached.

Solid state: D-M9□ Reed: D-A9□  
D-M9□W

Auto switch mounting screw

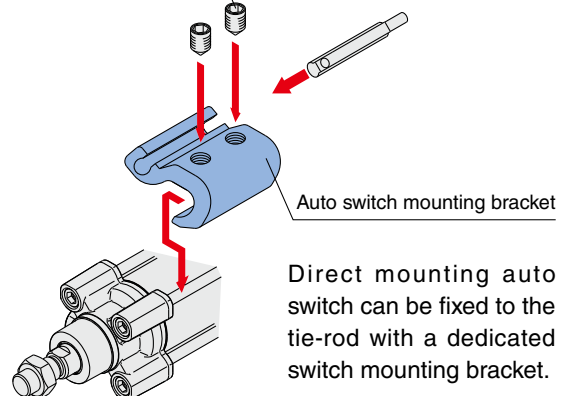

Direct mounting auto switch can be fixed to the tie-rod with a dedicated switch mounting bracket.

## Improved handling performance

Auto switch mounting and mounting position adjustment can be made in a one way direction.

Tie-rod mounting auto switch

Current

2-way

Direct mounting auto switch

1-way

New method

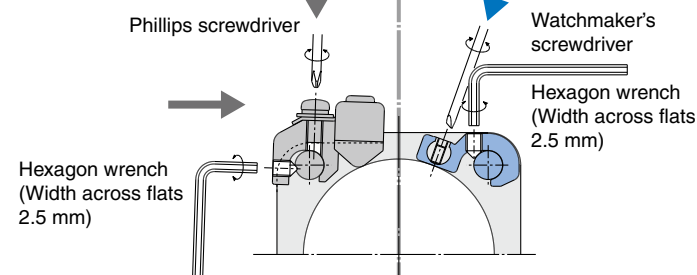

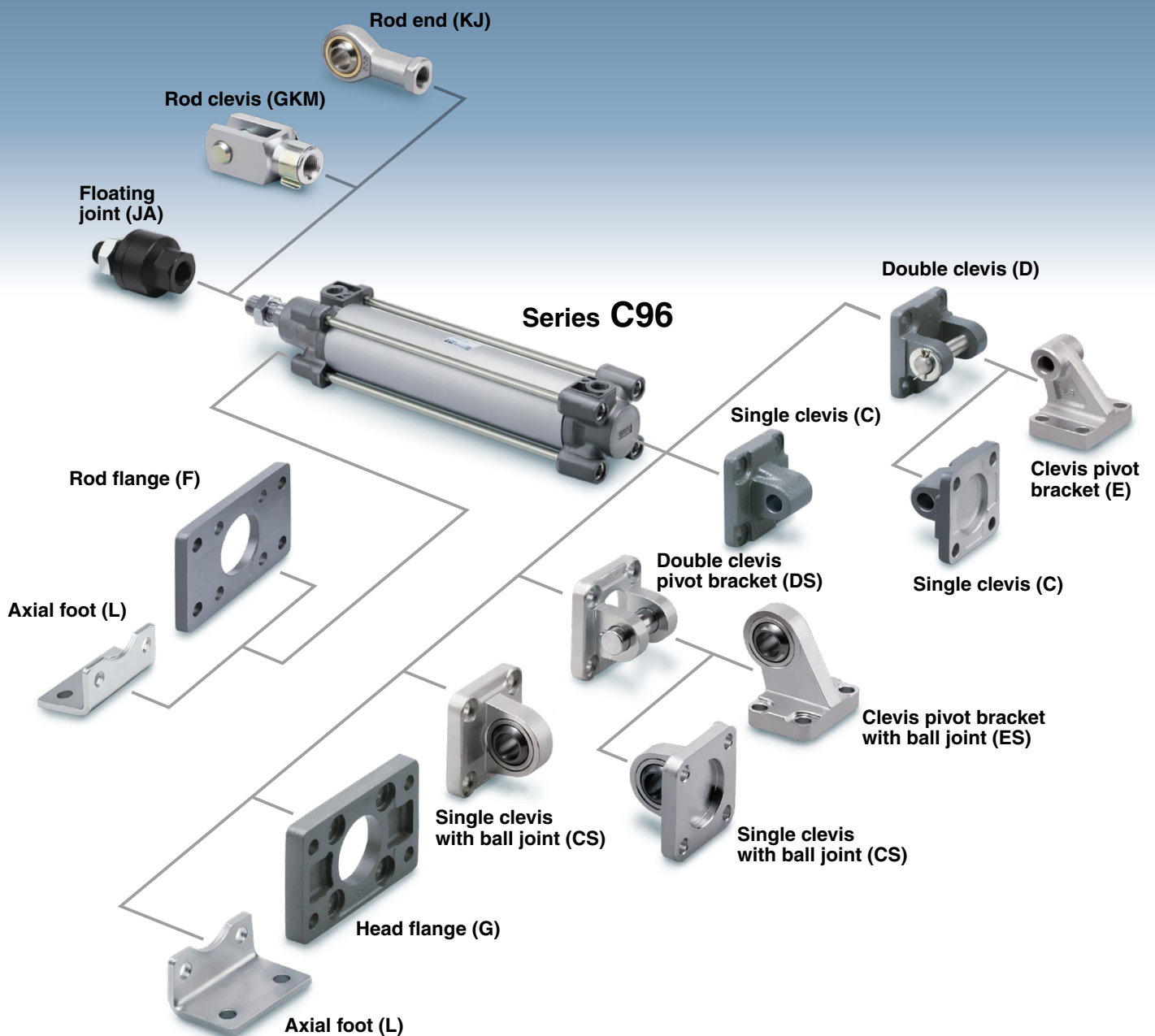

# Various mounting bracket options

Mounting brackets can be combined according to the operating conditions.

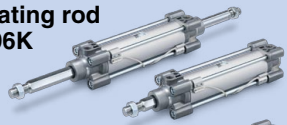

## Series Variations

Series	Type	Bore size [mm]						Page	
		32	40	50	63	80	100		125
<b>Standard</b> Series C96 	Double acting, Single rod	●	●	●	●	●	●	*	Page 3
	Double acting, Double rod	●	●	●	●	●	●	*	
<b>Non-rotating rod</b> Series C96K 	Double acting, Single rod	●	●	●	●	●	●		Page 15
	Double acting, Double rod	●	●	●	●	●	●		
<b>Smooth Cylinder</b> Series C96Y 	Double acting, Single rod	●	●	●	●	●	●	*	Page 19

\* Bore size 125 is the same as the current model. For details, refer to the [Web Catalog](#).

# ISO Standard (15552)

## Air Cylinder: Standard Type Double Acting, Single/Double Rod

# Series C96

ø32, ø40, ø50, ø63, ø80, ø100



The C96 series, standard type, ø125 is the same as the current model. For details, refer to the **Web Catalog**.

### How to Order

**C96S** **B** **32** - **100** **C** **J** **W** - [ ]

**With auto switch** **C96SD** **B** **32** - **100** **C** **J** **W** - **M9BW** **S** - [ ]

**Mounting**

<b>B</b>	Basic
<b>L</b>	Axial foot
<b>F</b>	Rod flange
<b>G</b>	Head flange
<b>C</b>	Single clevis
<b>D</b>	Double clevis
<b>T</b>	Center trunnion

**Bore size**

<b>32</b>	32 mm
<b>40</b>	40 mm
<b>50</b>	50 mm
<b>63</b>	63 mm
<b>80</b>	80 mm
<b>100</b>	100 mm

**Cylinder stroke [mm]**  
Refer to "Standard Strokes" on page 4.

**Rod**

<b>Nil</b>	Single rod
<b>W</b>	Double rod

**Rod boot**

<b>Nil</b>	Without rod boot
<b>J</b>	Nylon tarpaulin (One end)
<b>JJ</b>	Nylon tarpaulin (Both ends)
<b>K</b>	Heat resistant tarpaulin (One end)
<b>KK</b>	Heat resistant tarpaulin (Both ends)

**Number of auto switches**

<b>Nil</b>	2 pcs.
<b>S</b>	1 pc.
<b>3</b>	3 pcs.
<b>n</b>	"n" pcs.

**Made to Order**  
Refer to page 4 for details.

**Auto switch**

<b>Nil</b>	Without auto switch
------------	---------------------

\* Mounting brackets are shipped together, (but not assembled). (except center trunnion type)

**Air cushion on both ends + Bumper cushion**

\* For applicable auto switches, refer to the table below.

### Applicable Auto Switches/Refer to the WEB catalog or the Best Pneumatics No. 2 for further information on auto switches.

Type	Special function	Electrical entry	Indicator light	Wiring (Output)	Load voltage		Auto switch model		Lead wire length [m]				Pre-wired connector	Applicable load	
					DC	AC	Tie-rod mounting	Band mounting	0.5 (Nil)	1 (M)	3 (L)	5 (Z)			
Solid state auto switch	—	Grommet	—	3-wire (NPN)	5 V, 12 V	—	—	—	●	●	●	○	○	Relay, PLC	
				3-wire (PNP)					●	●	●	○	○		
		2-wire		●	●	●	○	○							
		—		—	—	—	—	—							
	Diagnostic indication (2-color indication)	Grommet	Yes	24 V	3-wire (NPN)	5 V, 12 V	—	—	—	●	●	●	○		○
					3-wire (PNP)					●	●	●	○		○
					2-wire	●	●	●	○	○					
					3-wire (NPN)	●	●	●	○	○					
					3-wire (PNP)	●	●	●	○	○					
					2-wire	●	●	●	○	○					
Water resistant (2-color indication)	Grommet	—	—	3-wire (NPN)	5 V, 12 V	—	—	—	○	○	●	○	○		
				3-wire (PNP)					○	○	●	○	○		
With diagnostic output (2-color indication)	Grommet	—	—	2-wire	12 V	—	—	—	○	○	●	○	○		
				4-wire (NPN)					○	○	●	○	○		
Magnetic field resistant (2-color indication)	Grommet	—	—	2-wire (Non-polar)	—	—	—	—	○	○	●	○	○		
				—					○	○	●	○	○		
Reed auto switch	—	Grommet	24 V	2-wire	12 V	—	—	—	●	—	●	—	—	Relay, PLC	
									—	●	●	●	●		—
									—	●	—	●	—		—
									—	●	—	●	—		—
		—							—	—	—	—	—		
		—							—	—	—	—	—		
	Diagnostic indication (2-color indication)	Grommet	Yes	—	—	—	—	—	—	●	—	●	—	—	
										—	—	—	—	—	—
										—	—	—	—	—	—
										—	—	—	—	—	—

\*1 Water resistant type auto switches can be mounted on the above models, but in such case SMC cannot guarantee water resistance.

\* Lead wire length symbols: 0.5 m ..... Nil (Example) M9NW  
 1 m ..... M (Example) M9NWM  
 3 m ..... L (Example) M9NWL  
 5 m ..... Z (Example) M9NwZ

\* Solid state auto switches marked with "○" are produced upon receipt of order.

\* Since there are other applicable auto switches than listed above, refer to the **WEB catalog** or the Best Pneumatics No. 2 for details.

\* For details about auto switches with pre-wired connector, refer to the **WEB catalog** or the Best Pneumatics No. 2.

\* The D-A9□/M9□/M9□W/M9□A auto switches are shipped together, (but not assembled).

(However, only the auto switch mounting brackets are assembled before shipment.)

## Specifications

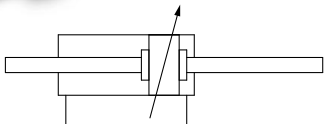
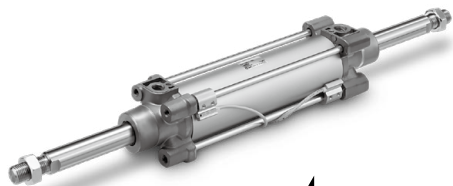
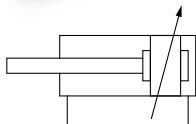

Bore size [mm]	32	40	50	63	80	100
<b>Action</b>	Double acting					
<b>Fluid</b>	Air					
<b>Proof pressure</b>	1.5 MPa					
<b>Max. operating pressure</b>	1.0 MPa					
<b>Min. operating pressure</b>	0.05 MPa					
<b>Ambient and fluid temperature</b>	Without auto switch: -20 to 70°C (No freezing) With auto switch: -10 to 60°C (No freezing)					
<b>Lubrication</b>	Not required (Non-lube)					
<b>Operating piston speed</b>	50 to 1000 mm/s					
<b>Allowable stroke tolerance</b>	Up to 500 stroke: ${}^{+2}_0$ , 501 to 1000 stroke: ${}^{+2.4}_0$ , 1001 to 1500 stroke: ${}^{+2.8}_0$ , 1501 to 2000 stroke: ${}^{+3.2}_0$					
<b>Cushion</b>	Air cushion on both ends + Bumper cushion					
<b>Port size</b>	G 1/8	G 1/4	G 1/4	G 3/8	G 3/8	G 1/2
<b>Mounting</b>	Basic, Axial foot, Rod flange, Head flange, Single clevis, Double clevis, Center trunnion					

## Standard Strokes

Bore size [mm]	Standard stroke [mm]	Max. stroke <sup>Note)</sup>
<b>32</b>	25, 50, 80, 100, 125, 160, 200, 250, 320, 400, 500	1000
<b>40</b>	25, 50, 80, 100, 125, 160, 200, 250, 320, 400, 500	1900
<b>50</b>	25, 50, 80, 100, 125, 160, 200, 250, 320, 400, 500, 600	1900
<b>63</b>	25, 50, 80, 100, 125, 160, 200, 250, 320, 400, 500, 600	1900
<b>80</b>	25, 50, 80, 100, 125, 160, 200, 250, 320, 400, 500, 600, 700, 800	1900
<b>100</b>	25, 50, 80, 100, 125, 160, 200, 250, 320, 400, 500, 600, 700, 800	1900

Intermediate strokes are available.

Note) Please consult with SMC for longer strokes.



**Made to Order**  
 (For details, refer to pages 32 to 41.)

Symbol	Specifications
<b>-XA</b> □	Change of rod end shape
<b>-XC14</b>	Change of trunnion bracket mounting position
<b>-XB6</b>	Heat resistant cylinder (-10 to 150°C)
<b>-XB7</b>	Cold resistant cylinder (-40 to 70°C)
<b>-XC4</b>	With heavy duty scraper
<b>-XC7</b>	Tie-rod, tie-rod nut, etc. made of stainless steel
<b>-XC10</b>	Dual stroke cylinder/Double rod type
<b>-XC11</b>	Dual stroke cylinder/Single rod type
<b>-XC22</b>	Fluororubber seal
<b>-XC35</b>	With coil scraper
<b>-XC65</b>	Made of stainless steel (Combination of -XC7 and -XC68)
<b>-XC68</b>	Made of stainless steel (with hard chrome plated piston rod)
<b>-XC88</b>	Spatter resistant coil scraper, Lube-retainer, grease for welding (Piston rod: Stainless steel 304)
<b>-XC89</b>	Spatter resistant coil scraper, Lube-retainer, grease for welding (Piston rod: S45C)

Refer to pages 23 to 27 for cylinders with auto switches.

- Auto switch proper mounting position (detection at stroke end) and its mounting height
- Minimum stroke for auto switch mounting
- Auto switch mounting brackets/Part no.
- Operating range

## Accessories

Mounting		Basic	Foot	Rod flange	Head flange	Single clevis	Double clevis	Center trunnion
Standard	Rod end nut	●	●	●	●	●	●	●
	Clevis pin	—	—	—	—	—	●	—
Option	Rod end	●	●	●	●	●	●	●
	Rod clevis	●	●	●	●	●	●	●
	Rod boot	●	●	●	●	●	●	●

\* Do not use a rod end (or floating joint) together with a single clevis with a ball joint (or clevis pivot bracket with a ball joint).

\* Refer to pages 10 to 14 for dimensions and part numbers of the accessories.

## ⚠ Precautions

**Be sure to read this before handling. Refer to the back cover for Safety Instructions. For Actuator and Auto Switch Precautions, refer to "Handling Precautions for SMC Products" and the Operation Manual on SMC website, <http://www.smcworld.com>**

# Series C96

## Theoretical Output



Bore size [mm]	Rod size [mm]	Operating direction	Piston area [mm <sup>2</sup> ]	Operating pressure [MPa]								
				0.2	0.3	0.4	0.5	0.6	0.7	0.8	0.9	1.0
32	12	OUT	804	161	241	322	402	482	563	643	724	804
		IN	691	138	207	276	346	415	484	553	622	691
40	16	OUT	1257	251	377	503	629	754	880	1006	1131	1257
		IN	1056	211	317	422	528	634	739	845	950	1056
50	20	OUT	1963	393	589	785	982	1178	1374	1570	1767	1963
		IN	1649	330	495	660	825	989	1154	1319	1484	1649
63	20	OUT	3117	623	935	1247	1559	1870	2182	2494	2805	3117
		IN	2803	561	841	1121	1402	1682	1962	2242	2523	2803
80	25	OUT	5027	1005	1508	2011	2514	3016	3519	4022	4524	5027
		IN	4536	907	1361	1814	2268	2722	3175	3629	4082	4536
100	25	OUT	7854	1571	2356	3142	3927	4712	5498	6283	7068	7854
		IN	7363	1473	2209	2945	3682	4418	5154	5890	6627	7363

Note) Theoretical output [N] = Pressure [MPa] x Piston area [mm<sup>2</sup>]

## Weights

Bore size [mm]		32	40	50	63	80	100
Basic weight	Basic	0.43	0.64	1.09	1.42	2.32	3.15
	Foot	0.16	0.20	0.38	0.46	0.89	1.09
	Flange	0.20	0.23	0.47	0.58	1.30	1.81
	Single clevis	0.16	0.23	0.37	0.60	1.07	1.73
	Double clevis	0.20	0.32	0.45	0.71	1.28	2.11
	Trunnion	0.71	1.10	1.73	2.48	4.25	5.95
Additional weight per 50 mm of stroke	All mounting brackets	0.11	0.16	0.24	0.26	0.40	0.44
Accessories	Rod end	0.07	0.11	0.22		0.40	
	Rod clevis	0.09	0.15	0.34		0.69	

Calculation: Example) **C96SD40-100C**

- Basic weight ..... 0.64 [kg] (Basic, ø40)
- Additional weight ..... 0.16 (kg/50 st)
- Cylinder stroke ..... 100 [st]
- Mounting bracket weight ..... 0.32 [kg] (Double clevis)

$$0.64 + 0.16 \times 100 \div 50 + 0.32 = 1.28 \text{ kg}$$

## Allowable Kinetic Energy

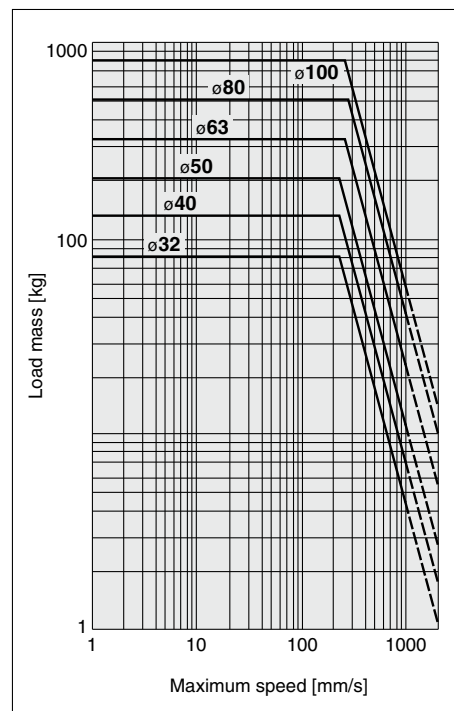

(Example) Find the upper limit of rod end load when an air cylinder of ø63 is operated at 500 mm/s. From a point indicating 500 mm/s on the axis of abscissas, extend a line upward and find a point where it intersects with a line for the 63 mm bore size. Extend a line from the intersection to the left and find a load mass 80 kg.

**Construction**

[First angle projection]

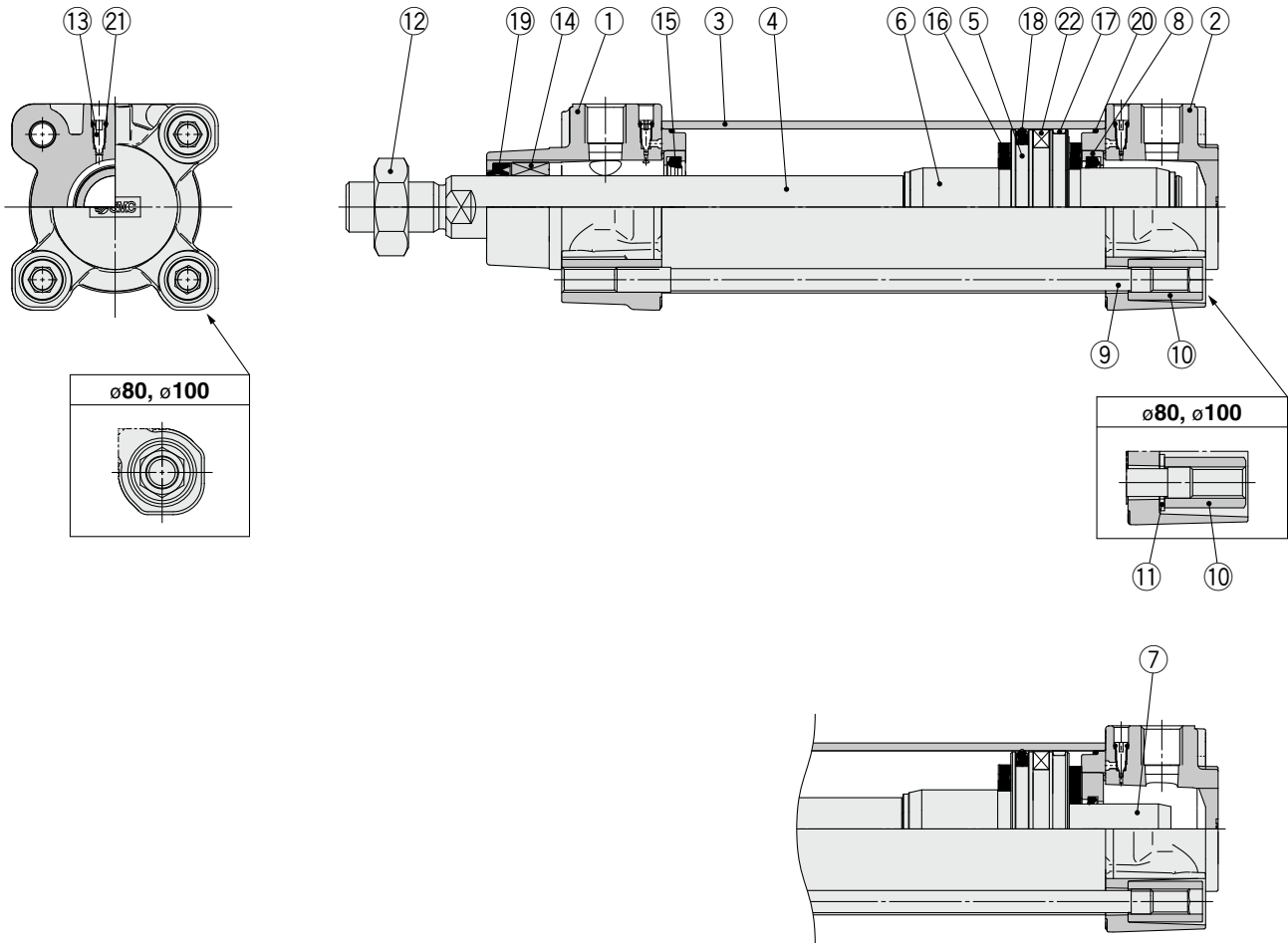

**Component Parts**

No.	Description	Material	Note
1	Rod cover	Aluminum die-cast	
2	Head cover	Aluminum die-cast	
3	Cylinder tube	Aluminum alloy	
4	Piston rod	Carbon steel	
5	Piston	Aluminum alloy	ø32 to ø63
		Aluminum die-cast	ø80, ø100
6	Cushion ring A	Aluminum alloy	
7	Cushion ring B	Aluminum alloy	
8	Cushion seal holder	Aluminum alloy	
9	Tie-rod	Carbon steel	
10	Tie-rod nut	Steel	
11	Flat washer	Steel	ø80, ø100
12	Rod end nut	Steel	
13	Cushion valve	Resin	
14	Bushing	Bearing alloy	
15	Cushion seal	Urethane	
16	Bumper	Urethane	
17	Wear ring	Resin	
18	Piston seal	NBR	
19	Rod seal	NBR	
20	Cylinder tube gasket	NBR	
21	Cushion valve seal	NBR	
22	Magnet		

**Replacement Parts/Seal Kit (Single rod)**

Bore size [mm]	Kit no.	Contents
32	CS95-32	Kits include items 15, 17 to 20.
40	CS95-40	
50	CS95-50	
63	CS95-63	
80	CS95-80	
100	CS96-100	

\* Seal kits consist of items 15, 17 to 20 and can be ordered by using the seal kit number corresponding to each bore size.

\* The seal kit includes a grease pack (10 g for ø32 to ø50, 20 g for ø63 and ø80, 30 g for ø100).

Order with the following part number when only the grease pack is needed.

**Grease pack part number: GR-S-010 (10 g), GR-S-020 (20 g)**

**Seal Kit (Double rod)**

Bore size [mm]	Kit no.	Contents
32	CS95W-32	Kits include items 15, 18 to 20
40	CS95W-40	
50	CS95W-50	
63	CS95W-63	
80	CS95W-80	
100	CS96W-100	

\* Seal kits consist of items 15, 18 to 20 and can be ordered by using the seal kit number corresponding to each bore size.

\* The seal kit includes a grease pack (10 g for ø32 to ø50, 20 g for ø63 and ø80, 30 g for ø100).

Order with the following part number when only the grease pack is needed.

**Grease pack part number: GR-S010 (10 g), GR-S-020 (20 g)**

# Series C96

## Dimensions

[First angle projection]

Basic: C96S (D) B Bore size – Stroke C (J)

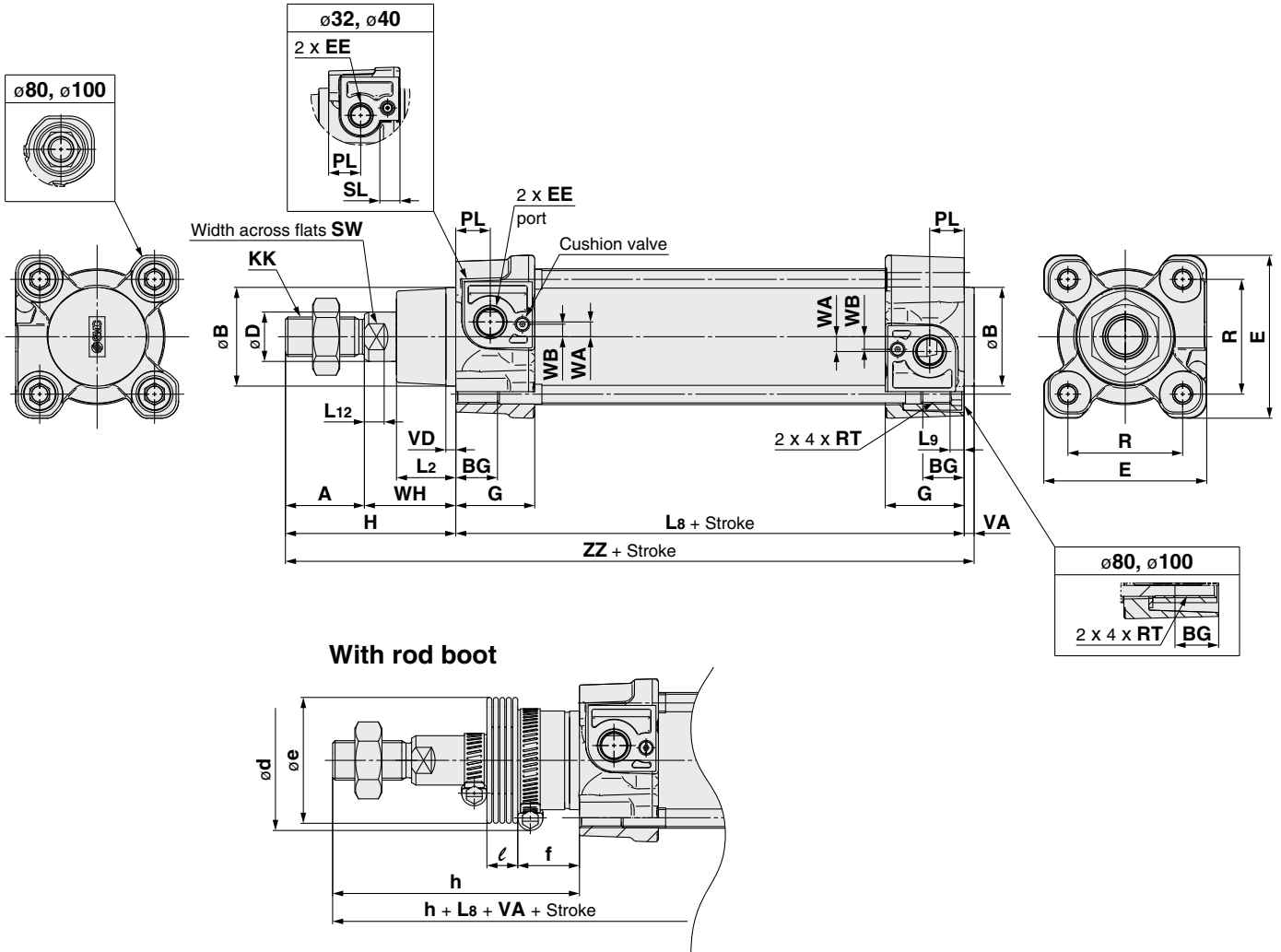

Bore size [mm]	Stroke range [mm]		A	øB d11	BG	øD	E	EE	G	H	KK	L2	L8	L9	L12	PL	R	RT	SL	SW	VA	VD	WA	WB	WH	ZZ
	Without rod boot	With rod boot																								
32	Up to 1000	Up to 1000	22	30	16	12	47	G 1/8	28.9	48	M10 x 1.25	15	94	4	6	13	32.5	M6 x 1	8	10	4	4	4	7	26	146
40	Up to 1900	Up to 1000	24	35	16	16	54	G 1/4	32.6	54	M12 x 1.25	17	105	4	6.5	14	38	M6 x 1	8	13	4	4	5	8.9	30	163
50	Up to 1900	Up to 1000	32	40	16	20	66	G 1/4	32	69	M16 x 1.5	24	106	5	8	14	46.5	M8 x 1.25	-	17	4	4	6	5.1	37	179
63	Up to 1900	Up to 1000	32	45	16	20	77	G 3/8	38.6	69	M16 x 1.5	24	121	5	8	16	56.5	M8 x 1.25	-	17	4	4	9	6.3	37	194
80	Up to 1900	Up to 1000	40	45	17	25	99	G 3/8	38.4	86	M20 x 1.5	30	128	-	10	16	72	M10 x 1.5	-	22	4	4	11.5	6	46	218
100	Up to 1900*	Up to 1000*	40	55	17	25	118	G 1/2	42.9	91	M20 x 1.5	32	138	-	10	18	89	M10 x 1.5	-	22	4	4	17	10	51	233

\* Minimum stroke for trunnion mounting: 1 mm for bore size 32 to 80, 5 mm for bore size 100

Bore size [mm]	øe	ød	f	ℓ																	h								
				1 to 50	51 to 100	101 to 150	151 to 200	201 to 300	301 to 400	401 to 500	501 to 600	601 to 700	701 to 800	801 to 900	901 to 1000	1 to 50	51 to 100	101 to 150	151 to 200	201 to 300	301 to 400	401 to 500	501 to 600	601 to 700	701 to 800	801 to 900	901 to 1000		
32	36	54	23	12.5	25	37.5	50	75	100	125	150	175	200	225	250	75	88	100	113	138	163	188	213	238	263	288	313		
40	36	54	23	12.5	25	37.5	50	75	100	125	150	175	200	225	250	75	88	100	113	138	163	188	213	238	263	288	313		
50	51	64	25	12.5	25	37.5	50	75	100	125	150	175	200	225	250	87	100	112	125	150	175	200	225	250	275	300	325		
63	51	64	25	12.5	25	37.5	50	75	100	125	150	175	200	225	250	87	100	112	125	150	175	200	225	250	275	300	325		
80	56	68	30	12.5	25	37.5	50	75	100	125	150	175	200	225	250	103	116	128	141	166	191	216	241	266	291	316	341		
100	56	76	32	12.5	25	37.5	50	75	100	125	150	175	200	225	250	103	116	128	141	166	191	216	241	266	291	316	341		



**Dimensions**

[First angle projection]

Basic: C96S (D) B Bore size – Stroke C (J) W

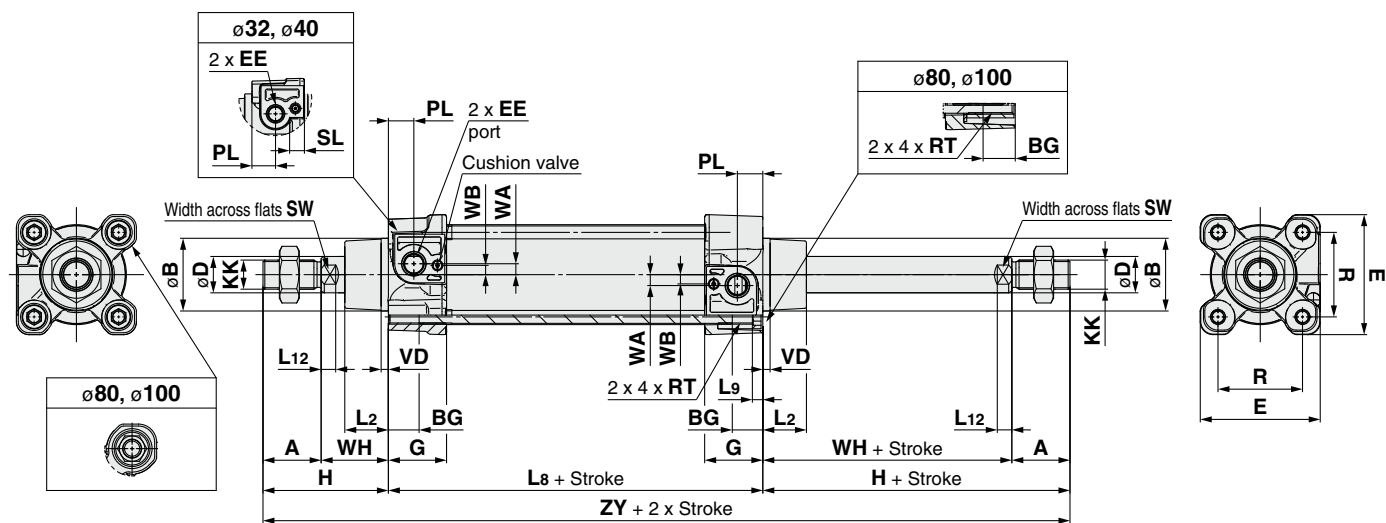

**With rod boot at one end**

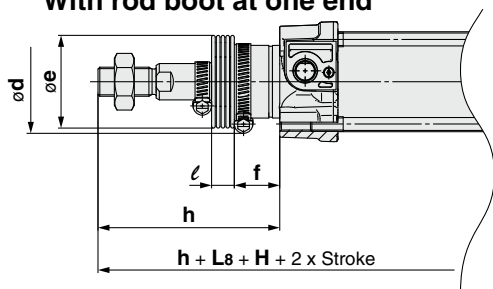

Bore size [mm]	Stroke range [mm]	A	øB d11	øD	EE	PL	RT	L12	KK	SW	G	BG	L8	VD	WA	WB	WH	ZY	E	R	L2	L9	H	SL
32	Up to 1000	22	30	12	G 1/8	13	M6 x 1	6	M10 x 1.25	10	28.9	16	94	4	4	7	26	190	47	32.5	15	4	48	8
40	Up to 1000	24	35	16	G 1/4	14	M6 x 1	6.5	M12 x 1.25	13	32.6	16	105	4	5	8.9	30	213	54	38	17	4	54	8
50	Up to 1000	32	40	20	G 1/4	14	M8 x 1.25	8	M16 x 1.5	17	32	16	106	4	6	5.1	37	244	66	46.5	24	5	69	-
63	Up to 1000	32	45	20	G 3/8	16	M8 x 1.25	8	M16 x 1.5	17	38.6	16	121	4	9	6.3	37	259	77	56.5	24	5	69	-
80	Up to 1000	40	45	25	G 3/8	16	M10 x 1.5	10	M20 x 1.5	22	38.4	17	128	4	11.5	6	46	300	99	72	30	-	86	-
100	Up to 1000*	40	55	25	G 1/2	18	M10 x 1.5	10	M20 x 1.5	22	42.9	17	138	4	17	10	51	320	118	89	32	-	91	-

\* Minimum stroke for trunnion mounting: 1 mm for bore size 32 to 80, 5 mm for bore size 100

Bore size [mm]	øe	ød	f	ℓ												h											
				1 to 50	51 to 100	101 to 150	151 to 200	201 to 300	301 to 400	401 to 500	501 to 600	601 to 700	701 to 800	801 to 900	901 to 1000	1 to 50	51 to 100	101 to 150	151 to 200	201 to 300	301 to 400	401 to 500	501 to 600	601 to 700	701 to 800	801 to 900	901 to 1000
32	36	54	23	12.5	25	37.5	50	75	100	125	150	175	200	225	250	75	88	100	113	138	163	188	213	238	263	288	313
40	36	54	23	12.5	25	37.5	50	75	100	125	150	175	200	225	250	75	88	100	113	138	163	188	213	238	263	288	313
50	51	64	25	12.5	25	37.5	50	75	100	125	150	175	200	225	250	87	100	112	125	150	175	200	225	250	275	300	325
63	51	64	25	12.5	25	37.5	50	75	100	125	150	175	200	225	250	87	100	112	125	150	175	200	225	250	275	300	325
80	56	68	30	12.5	25	37.5	50	75	100	125	150	175	200	225	250	103	116	128	141	166	191	216	241	266	291	316	341
100	56	76	32	12.5	25	37.5	50	75	100	125	150	175	200	225	250	103	116	128	141	166	191	216	241	266	291	316	341

# Series C96

## Dimensions

[First angle projection]

Basic: C96S (D) B Bore size – Stroke C (JJ) W

With rod boot at both ends

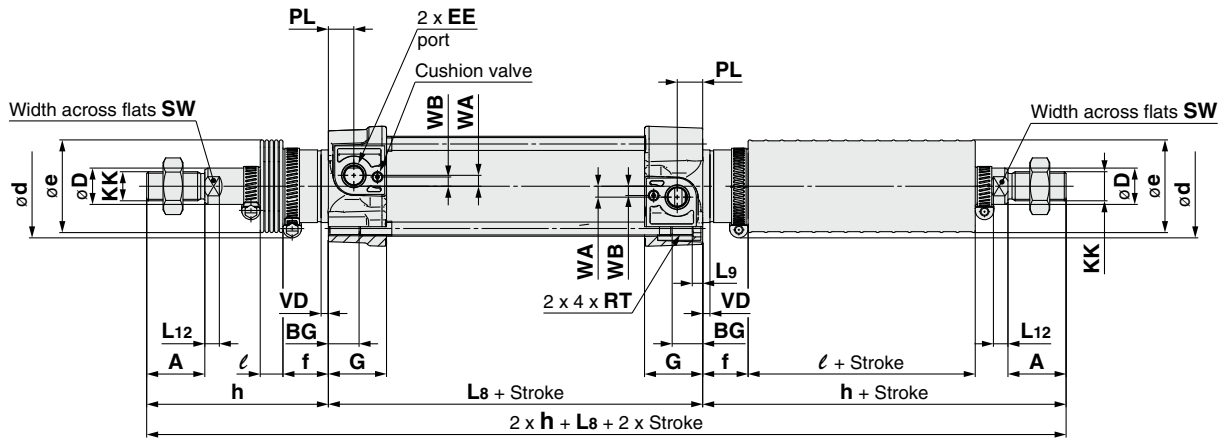

Bore size [mm]	Stroke range [mm]	A	∅D	EE	PL	RT	L12	KK	SW	G	BG	L8	VD	WA	WB	E	R	L9	SL
32	Up to 1000	22	12	G 1/8	13	M6 x 1	6	M10 x 1.25	10	28.9	16	94	4	4	7	47	32.5	4	8
40	Up to 1000	24	16	G 1/4	14	M6 x 1	6.5	M12 x 1.25	13	32.6	16	105	4	5	8.9	54	38	4	8
50	Up to 1000	32	20	G 1/4	14	M8 x 1.25	8	M16 x 1.5	17	32	16	106	4	6	5.1	66	46.5	5	–
63	Up to 1000	32	20	G 3/8	16	M8 x 1.25	8	M16 x 1.5	17	38.6	16	121	4	9	6.3	77	56.5	5	–
80	Up to 1000	40	25	G 3/8	16	M10 x 1.5	10	M20 x 1.5	22	38.4	17	128	4	11.5	6	99	72	–	–
100	Up to 1000*	40	25	G 1/2	18	M10 x 1.5	10	M20 x 1.5	22	42.9	17	138	4	17	10	118	89	–	–

\* Minimum stroke for trunnion mounting: 1 mm for bore size 32 to 80, 5 mm for bore size 100

Bore size [mm]	∅e	∅d	f	ℓ												h											
				1 to 50	51 to 100	101 to 150	151 to 200	201 to 300	301 to 400	401 to 500	501 to 600	601 to 700	701 to 800	801 to 900	901 to 1000	1 to 50	51 to 100	101 to 150	151 to 200	201 to 300	301 to 400	401 to 500	501 to 600	601 to 700	701 to 800	801 to 900	901 to 1000
32	36	54	23	12.5	25	37.5	50	75	100	125	150	175	200	225	250	75	88	100	113	138	163	188	213	238	263	288	313
40	36	54	23	12.5	25	37.5	50	75	100	125	150	175	200	225	250	75	88	100	113	138	163	188	213	238	263	288	313
50	51	64	25	12.5	25	37.5	50	75	100	125	150	175	200	225	250	87	100	112	125	150	175	200	225	250	275	300	325
63	51	64	25	12.5	25	37.5	50	75	100	125	150	175	200	225	250	87	100	112	125	150	175	200	225	250	275	300	325
80	56	68	30	12.5	25	37.5	50	75	100	125	150	175	200	225	250	103	116	128	141	166	191	216	241	266	291	316	341
100	56	76	32	12.5	25	37.5	50	75	100	125	150	175	200	225	250	103	116	128	141	166	191	216	241	266	291	316	341

**Dimensions: With Mounting Bracket** (Dimensions are common to single rod and double rod.)

[First angle projection]

**Axial foot (L)**

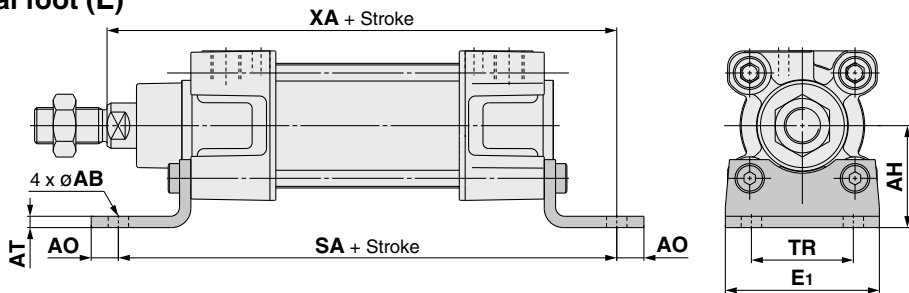

Bore size [mm]	E1	TR	AH	AO	AT	AB	SA	XA
32	48	32	32	10	4.5	7	142	144
40	55	36	36	11	4.5	10	161	163
50	68	45	45	12	5.5	10	170	175
63	80	50	50	12	5.5	10	185	190
80	100	63	63	14	6.5	12	210	215
100	120	75	71	16	6.5	14.5	220	230

**Center trunnion (T)**

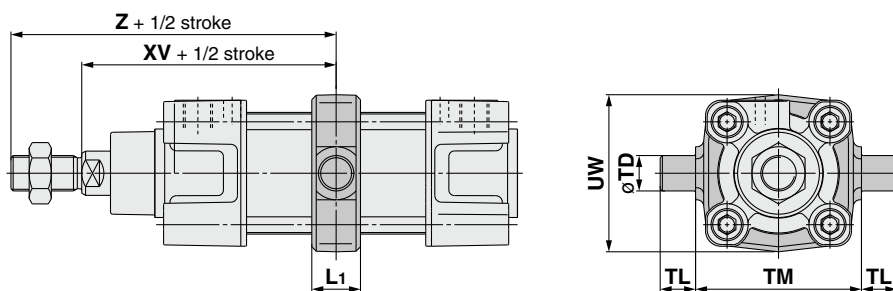

Bore size [mm]	TM	TL	TD <sub>e8</sub>	UW	L1	XV	Z
32	50	12	12	49	17	73	95
40	63	16	16	58	22	82.5	106.5
50	75	16	16	71	22	90	122
63	90	20	20	87	28	97.5	129.5
80	110	20	20	110	34	110	150
100	132	25	25	136	40	120	160

**Rod flange (F)**

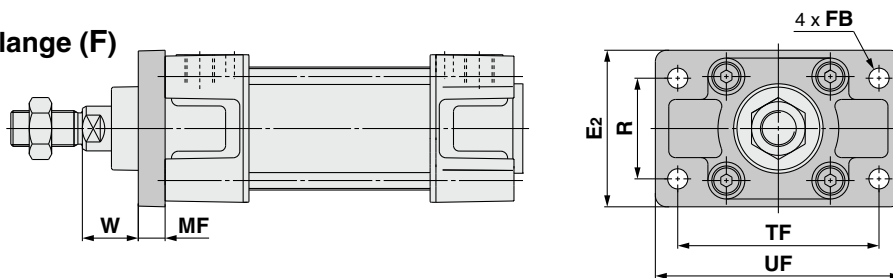

Bore size [mm]	R	TF	FB	E2	UF	W	MF
32	32	64	7	50	79	16	10
40	36	72	9	55	90	20	10
50	45	90	9	70	110	25	12
63	50	100	9	80	120	25	12
80	63	126	12	100	153	30	16
100	75	150	14	120	178	35	16

**Head flange (G)**

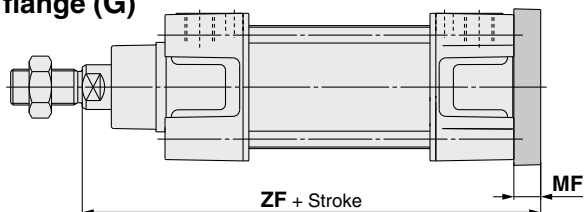

Bore size [mm]	MF	ZF
32	10	130
40	10	145
50	12	155
63	12	170
80	16	190
100	16	205

**Single clevis (C)**

**Double clevis (D)**

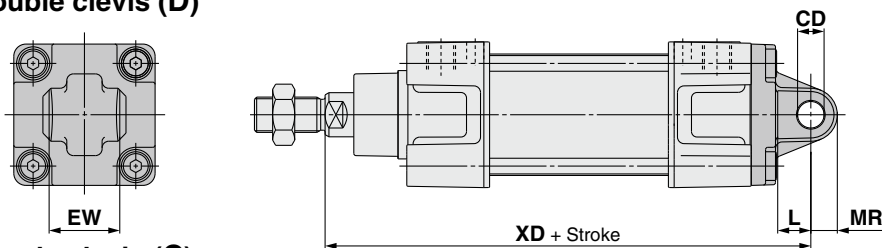

Bore size [mm]	EW	CD <sub>H9</sub>	L	MR	XD	UB <sub>h14</sub>	CB <sub>H14</sub>	EB
32	26 <sup>-0.2</sup> <sub>-0.6</sub>	10	12	9.5	142	45	26	65
40	28 <sup>-0.2</sup> <sub>-0.6</sub>	12	15	12	160	52	28	75
50	32 <sup>-0.2</sup> <sub>-0.6</sub>	12	15	12	170	60	32	80
63	40 <sup>-0.2</sup> <sub>-0.6</sub>	16	20	16	190	70	40	90
80	50 <sup>-0.2</sup> <sub>-0.6</sub>	16	20	16	210	90	50	110
100	60 <sup>-0.2</sup> <sub>-0.6</sub>	20	25	20	230	110	60	140

**Single clevis (C)**

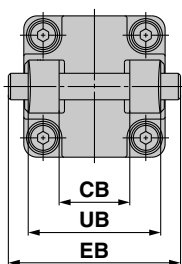

**Double clevis (D)**

# Series C96 Accessories

## Dimensions: Mounting Brackets

[First angle projection]

### Axial foot (L)

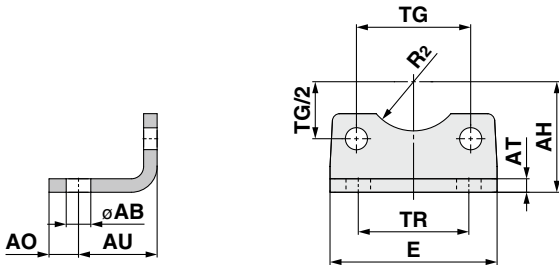

Bore size [mm]	Part no.	AB	TG $\pm 0.2$	E	TR	AO	AU	AH	AT	R2	Screw size
32	L5032	7	32.5	48	32	10	24	32	4.5	15	M6 x 16L
40	L5040	10	38	55	36	11	28	36	4.5	17.5	M6 x 16L
50	L5050	10	46.5	68	45	12	32	45	5.5	20	M8 x 20L
63	L5063	10	56.5	80	50	12	32	50	5.5	22.5	M8 x 20L
80	L5080	12	72	100	63	14	41	63	6.5	22.5	M10 x 20L
100	L5100	14.5	89	120	75	16	41	71	6.5	27.5	M10 x 20L

\* Supplied with 4 mounting screws.

### Flange (F, G)

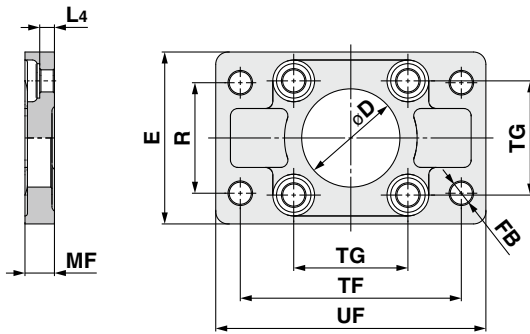

Bore size [mm]	Part no.	D H11	$\phi$ FB	TG $\pm 0.2$	E	R	MF	TF	UF	L4	Screw size
32	F5032	30	7	32.5	50	32	10	64	79	5	M6 x 20L
40	F5040	35	9	38	55	36	10	72	90	5	M6 x 20L
50	F5050	40	9	46.5	70	45	12	90	110	6.5	M8 x 20L
63	F5063	45	9	56.5	80	50	12	100	120	6.5	M8 x 20L
80	F5080	45	12	72	100	63	16	126	153	9	M10 x 25L
100	F5100	55	14	89	120	75	16	150	178	9	M10 x 25L

\* Supplied with 4 mounting screws.

### Single clevis (C)

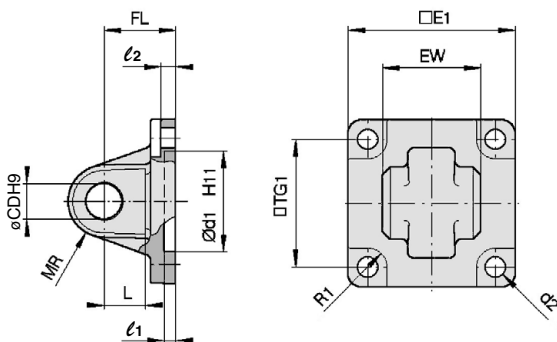

Bore size [mm]	Part no.	E1	EW	TG1	FL	$l_1$	L	$l_2$	$\phi d_1$	$\phi d_{CD}$	MR	$\phi d_2$	R1
32	C5032	45	26 $^{-0.2}_{-0.6}$	32.5	22	5	12	5.5	30	10	9.5	6.6	6.5
40	C5040	51	28 $^{-0.2}_{-0.6}$	38	25	5	15	5.5	35	12	12	6.6	6.5
50	C5050	64	32 $^{-0.2}_{-0.6}$	46.5	27	5	15	6.5	40	12	12	9	8.5
63	C5063	74	40 $^{-0.2}_{-0.6}$	56.5	32	5	20	6.5	45	16	16	9	8.5
80	C5080	94	50 $^{-0.2}_{-0.6}$	72	36	5	20	10	45	16	16	11	11
100	C5100	113	60 $^{-0.2}_{-0.6}$	89	41	5	25	10	55	20	20	11	12

\* Supplied with 4 mounting screws.

**Dimensions: Mounting Brackets, Pivot Brackets for Cylinder Mounting**

[First angle projection]

**Double clevis (D)**

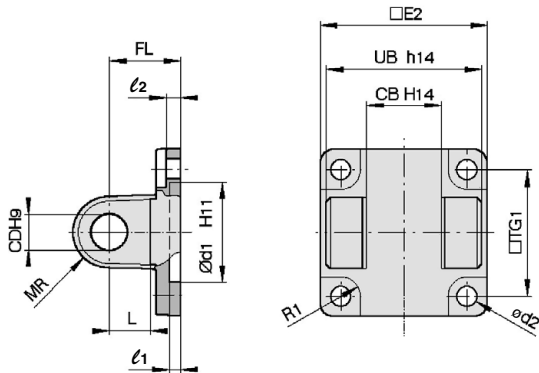

Bore size [mm]	Part no.	TG <sub>1</sub>	FL	l <sub>1</sub>	L	l <sub>2</sub>	ød <sub>1</sub>	øCD	MR	ød <sub>2</sub>	R <sub>1</sub>	E <sub>2</sub>	UB	CB
32	D5032	32.5	22	5	12	5.5	30	10	9.5	6.6	6.5	48	45	26
40	D5040	38	25	5	15	5.5	35	12	12	6.6	6.5	56	52	28
50	D5050	46.5	27	5	15	6.5	40	12	12	9	8.5	64	60	32
63	D5063	56.5	32	5	20	6.5	45	16	16	9	8.5	75	70	40
80	D5080	72	36	5	20	10	45	16	16	11	11	95	90	50
100	D5100	89	41	5	25	10	55	20	20	11	12	115	110	60

\* Supplied with 4 mounting screws, clevis pin, and clevis pin bracket.

**Clevis pivot bracket (E)**

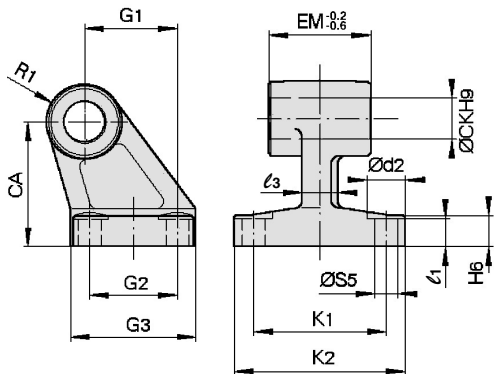

Bore size [mm]	Part no.	ød <sub>2</sub>	øCK	øS5	K <sub>1</sub>	K <sub>2</sub> (Max.)	l <sub>3</sub> (Max.)	G <sub>1</sub>	l <sub>1</sub>	G <sub>2</sub>	EM	G <sub>3</sub> (Max.)	CA	H <sub>6</sub>	R <sub>1</sub>
32	E5032	11	10	6.6	38	51	10	21	7	18	26 <sup>-0.2</sup> <sub>-0.6</sub>	31	32	8	10
40	E5040	11	12	6.6	41	54	10	24	9	22	28 <sup>-0.2</sup> <sub>-0.6</sub>	35	36	10	11
50	E5050	15	12	9	50	65	12	33	11	30	32 <sup>-0.2</sup> <sub>-0.6</sub>	45	45	12	12
63	E5063	15	16	9	52	67	14	37	11	35	40 <sup>-0.2</sup> <sub>-0.6</sub>	50	50	12	15
80	E5080	18	16	11	66	86	18	47	12.5	40	50 <sup>-0.2</sup> <sub>-0.6</sub>	60	63	14	15
100	E5100	18	20	11	76	96	20	55	13.5	50	60 <sup>-0.2</sup> <sub>-0.6</sub>	70	71	15	19

**Single clevis with ball joint (CS)**

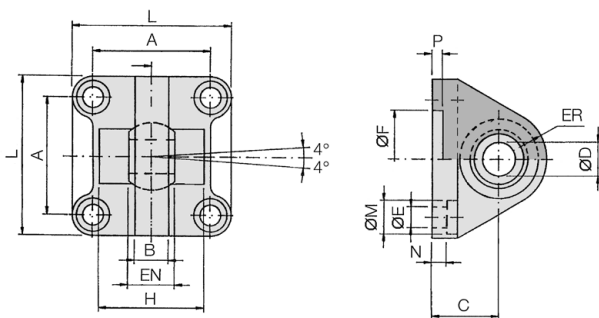

Bore size [mm]	Part no.	A	B (Max.)	C	øDH <sub>7</sub>	EN <sub>0 -0.1</sub>	ER (Max.)	øFH <sub>11</sub>	øE	L	øM	N	P	H ±0.5
32	CS5032	32.5	10.5	22	10	14	15	30	6.6	45	10.5	5.5	5	—
40	CS5040	38	12	25	12	16	18	35	6.6	55	11	5.5	5	—
50	CS5050	46.5	15	27	16	21	20	40	9	65	15	6.5	5	51
63	CS5063	56.5	15	32	16	21	23	45	9	75	15	6.5	5	—
80	CS5080	72	18	36	20	25	27	45	11	95	18	10	5	70
100	CS5100	89	18	41	20	25	30	55	11	115	18	10	5	—

\* Supplied with 4 mounting screws.

# Series C96

## Dimensions: Pivot Brackets for Cylinder Mounting

[First angle projection]

### Double clevis pivot bracket (DS)/for ES accessory

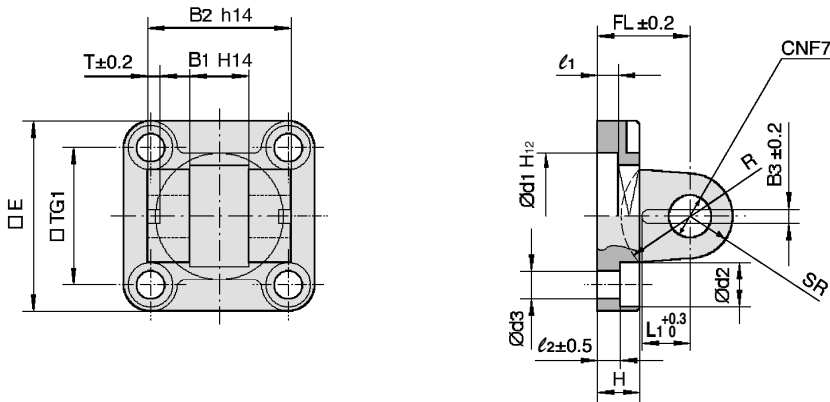

[mm]

Bore size [mm]	Part no.	E	B <sub>1</sub>	B <sub>2</sub>	B <sub>3</sub>	L <sub>1</sub>	TG <sub>1</sub>	T	l <sub>1</sub> (Min.)	l <sub>2</sub>	FL	H (Max.)	Ød <sub>1</sub>	Ød <sub>2</sub>	Ød <sub>3</sub>	ØCN	SR (Max.)	R
32	DS5032	45	14	34	3.3	11.5	32.5	3	5	5.5	22	10	30	10.5	6.6	10	11	17
40	DS5040	55	16	40	4.3	12	38	4	5	5.5	25	10	35	11	6.6	12	13	20
50	DS5050	65	21	45	4.3	14	46.5	4	5	6.5	27	12	40	15	9	16	18	22
63	DS5063	75	21	51	4.3	14	56.5	4	5	6.5	32	12	45	15	9	16	18	25
80	DS5080	95	25	65	4.3	16	72	4	5	10	36	16	45	18	11	20	22	30
100	DS5100	115	25	75	6.3	16	89	4	5	10	41	16	55	18	11	20	22	32

\* Supplied with 4 mounting screws, clevis pin, and clevis pin bracket.

### Clevis pivot bracket with ball joint (ES)

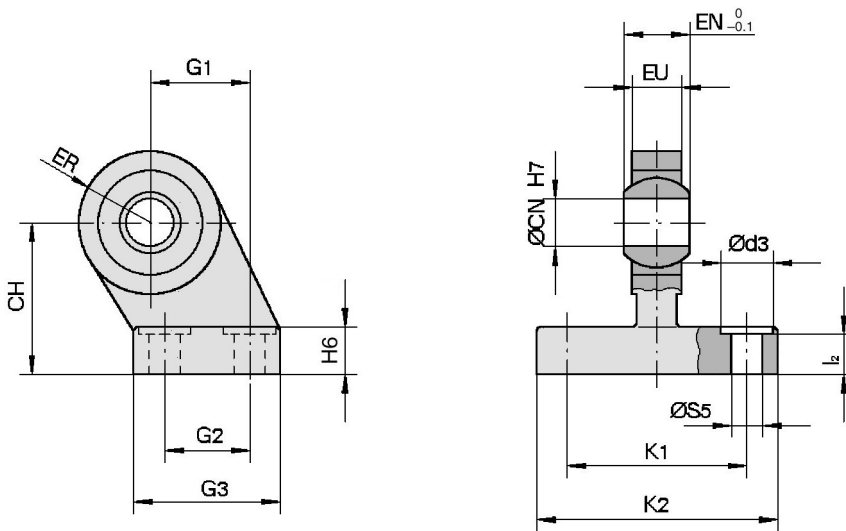

[mm]

Bore size [mm]	Part no.	Ød <sub>3</sub>	ØCN	ØS <sub>5</sub>	K <sub>1</sub>	K <sub>2</sub> (Max.)	l <sub>2</sub>	G <sub>1</sub>	G <sub>2</sub>	G <sub>3</sub> (Max.)	EN	EU	CH	H <sub>6</sub>	ER (Max.)
32	ES5032	11	10	6.6	38	51	8.5	21	18	31	14	10.5	32	10	15
40	ES5040	11	12	6.6	41	54	8.5	24	22	35	16	12	36	10	18
50	ES5050	15	16	9	50	65	10.5	33	30	45	21	15	45	12	20
63	ES5063	15	16	9	52	67	10.5	37	35	50	21	15	50	12	23
80	ES5080	18	20	11	66	86	11.5	47	40	60	25	18	63	14	27
100	ES5100	18	20	11	76	96	12.5	55	50	70	25	18	71	15	30

**Dimensions: Piston Rod Accessories**

[First angle projection]

**Floating joint: JA**

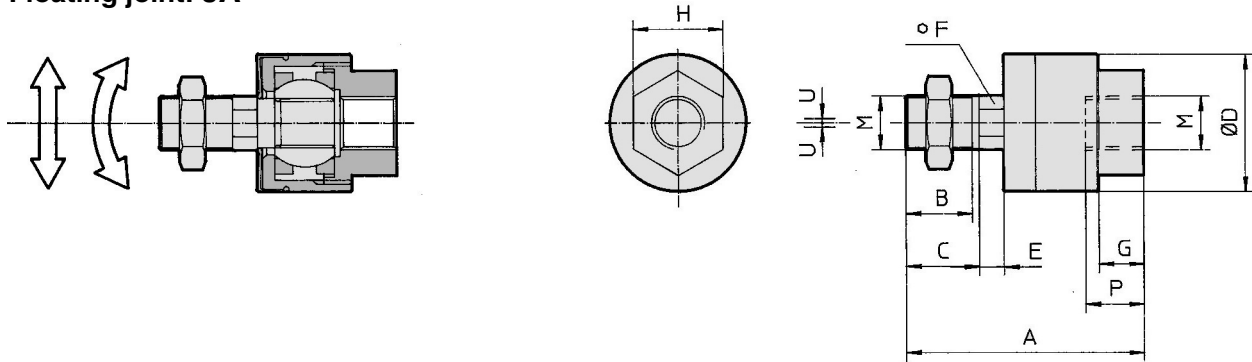

Bore size [mm]	Part no.	M	A	B	C	ØD	E	F	G	H	P	U	Load [kN]	Weight [g]	Angle
32	JA30-10-125	M10 x 1.25	49.5	19.5	—	24	5	8	8	17	9	0.5	2.5	70	±0.5°
40	JA40-12-125	M12 x 1.25	60	20	—	31	6	11	11	22	13	0.75	4.4	160	
50, 63	JA50-16-150	M16 x 1.5	71.5	22	—	41	7.5	14	13.5	27	15	1	11	300	
80, 100	JAH50-20-150	M20 x 1.5	101	28	31	59.5	11.5	24	16	32	18	2	18	1080	

\* Black color

**Rod clevis: GKM (ISO 8140)**

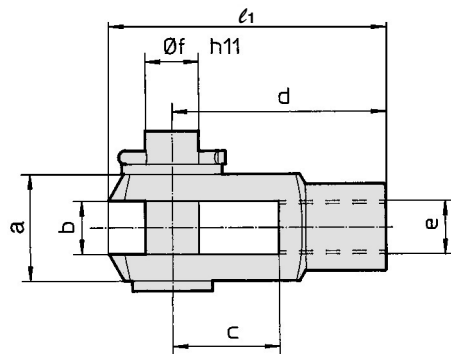

Bore size [mm]	Part no.	e	b	d	Øf h11 (Shaft)	Øf H9 (Hole)	l <sub>1</sub>	c (Min.)	a (Max.)
32	GKM10-20	M10 x 1.25	10 <sup>+0.5</sup> / <sub>+0.15</sub>	40	10	10	52	20	20
40	GKM12-24	M12 x 1.25	12 <sup>+0.5</sup> / <sub>+0.15</sub>	48	12	12	62	24	24
50, 63	GKM16-32	M16 x 1.5	16 <sup>+0.5</sup> / <sub>+0.15</sub>	64	16	16	83	32	32
80, 100	GKM20-40	M20 x 1.5	20 <sup>+0.5</sup> / <sub>+0.15</sub>	80	20	20	105	40	40

\* Supplied with clevis pin and clevis pin bracket.

**Rod end: KJ (ISO 8139)**

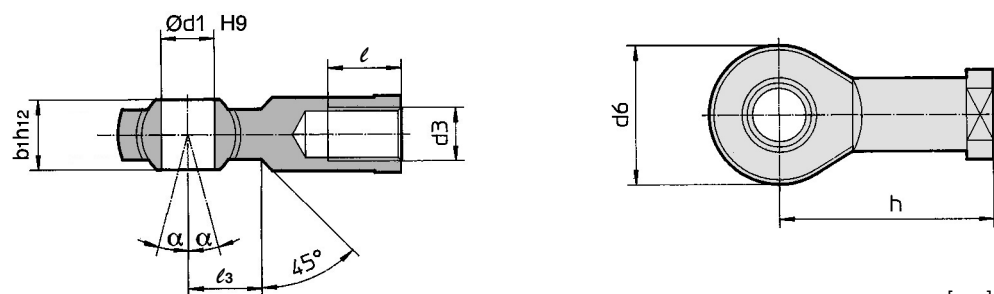

Bore size [mm]	Part no.	d <sub>3</sub>	Ød <sub>1</sub> H9	h	d <sub>6</sub> (Max.)	b <sub>1</sub> h <sub>12</sub>	l (Min.)	α	l <sub>3</sub>
32	KJ10D	M10 x 1.25	10	43	28	14	20	4°	15
40	KJ12D	M12 x 1.25	12	50	32	16	22	4°	17
50, 63	KJ16D	M16 x 1.5	16	64	42	21	28	4°	23
80, 100	KJ20D	M20 x 1.5	20	77	50	25	33	4°	27

# ISO (15552) Standard

## Air Cylinder: Non-rotating Rod Type Double Acting, Single/Double Rod

# Series C96K

∅32, ∅40, ∅50, ∅63, ∅80, ∅100

### How to Order



**C96K** **B** **32** - **100** **C** **W**

With auto switch

**C96KD** **B** **32** - **100** **C** **W** - **M9BW** **S**

With auto switch  
(Built-in magnet)

Mounting

<b>B</b>	Basic
<b>L</b>	Axial foot
<b>F</b>	Rod flange
<b>G</b>	Head flange
<b>C</b>	Single clevis
<b>D</b>	Double clevis
<b>T</b>	Center trunnion

\* Mounting brackets are shipped together, (but not assembled).  
(except center trunnion type)

Bore size

<b>32</b>	32 mm
<b>40</b>	40 mm
<b>50</b>	50 mm
<b>63</b>	63 mm
<b>80</b>	80 mm
<b>100</b>	100 mm

Rod

<b>Nil</b>	Single rod
<b>W</b>	Double rod

Air cushion on both ends +  
Bumper cushion

Cylinder stroke [mm]

Refer to "Maximum Strokes" on page 16.

Number of auto switches

<b>Nil</b>	2 pcs.
<b>S</b>	1 pc.
<b>3</b>	3 pcs.
<b>n</b>	"n" pcs.

Auto switch

<b>Nil</b>	Without auto switch
------------	---------------------

\* For applicable auto switches, refer to the table below.

### Applicable Auto Switches/Refer to the Web Catalog or Best Pneumatics for further information on auto switches.

Type	Special function	Electrical entry	Indicator light	Wiring (Output)	Load voltage		Auto switch model		Lead wire length [m]				Pre-wired connector	Applicable load		
					DC	AC	Tie-rod mounting	Band mounting	0.5 (Nil)	1 (M)	3 (L)	5 (Z)				
Solid state auto switch	—	Grommet	No	3-wire (NPN)	5 V, 12 V	—	<b>M9N</b>	—	●	●	●	○	○	—	IC circuit	
				3-wire (PNP)			—	●	●	●	○	○				
		2-wire		12 V	—	●	●	●	○	○	—	—				
		3-wire (NPN)		5 V, 12 V	—	<b>G39</b>	—	—	—	—			—			
	Diagnostic indication (2-color indication)	Grommet	Yes	3-wire (NPN)	5 V, 12 V	24 V	—	<b>M9NW</b>	—	●	●	●	○	○	—	IC circuit
				3-wire (PNP)				—	●	●	●	○	○			
		2-wire		12 V	—	<b>M9BW</b>	—	●	●	●	○	○	—	—		
		3-wire (NPN)		5 V, 12 V	—	<b>M9NA</b> *1	—	○	○	●	○	○				
		3-wire (PNP)		5 V, 12 V	—	<b>M9PA</b> *1	—	○	○	●	○	○				
		2-wire		12 V	—	<b>M9BA</b> *1	—	○	○	●	○	○				
Water resistant (2-color indication)	Grommet	No	3-wire (NPN)	5 V, 12 V	—	—	<b>F59F</b>	—	●	—	●	○	○	—	IC circuit	
3-wire (PNP)	5 V, 12 V		<b>P4DW</b>	—			—	—	●	●	○	—				
With diagnostic output (2-color indication)	Grommet	No	2-wire	12 V	24 V	—	<b>A96</b>	—	●	—	●	—	—	—	IC circuit	
4-wire (NPN)			5 V, 12 V	<b>A93</b>			—	●	●	●	●	—	—			
Magnetic field resistant (2-color indication)	Grommet	No	3-wire (NPN Equivalent)	—	5 V	—	<b>A90</b>	—	●	—	●	—	—	—	IC circuit	
							<b>A54</b>	—	●	—	●	●	—			—
	Terminal conduit	Yes	2-wire	24 V	12 V	—	—	<b>A64</b>	—	●	—	●	—	—	—	—
								<b>A33</b>	—	—	—	—	—	—		
	DIN terminal	Yes	2-wire	24 V	100 V, 200 V	—	—	<b>A34</b>	—	—	—	—	—	—	—	—
								<b>A44</b>	—	—	—	—	—	—		
Diagnostic indication (2-color indication)	Grommet	No	3-wire (NPN Equivalent)	—	5 V	—	<b>A59W</b>	—	●	—	●	—	—	—	IC circuit	

\*1 Water resistant type auto switches can be mounted on the above models, but in such case SMC cannot guarantee water resistance. Please contact SMC regarding water resistant types with the above model numbers.

\* Lead wire length symbols: 0.5 m ..... Nil (Example) M9NW  
1 m ..... M (Example) M9NWM  
3 m ..... L (Example) M9NWL  
5 m ..... Z (Example) M9NWZ

\* Solid state auto switches marked with "○" are produced upon receipt of order.

\* Since there are other applicable auto switches than listed above, refer to the Best Pneumatics No. 2 for details.

\* For details about auto switches with pre-wired connector, refer to the Best Pneumatics No. 2.

\* The D-A9□/M9□/M9□W/M9□A auto switches are shipped together, (but not assembled).  
(However, only the auto switch mounting brackets are assembled before shipment.)



## Specifications

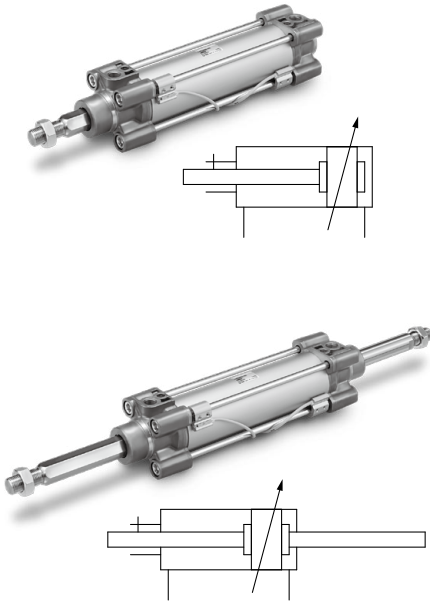

Bore size [mm]	32	40	50	63	80	100
<b>Action</b>	Double acting					
<b>Fluid</b>	Air					
<b>Proof pressure</b>	1.5 MPa					
<b>Maximum operating pressure</b>	1.0 MPa					
<b>Minimum operating pressure</b>	0.05 MPa					
<b>Ambient and fluid temperature</b>	Without auto switch: -20 to 70°C (No freezing) With auto switch: -10 to 60°C (No freezing)					
<b>Lubrication</b>	Not required (Non-lube)					
<b>Operating piston speed</b>	50 to 1000 mm/s					
<b>Allowable stroke tolerance</b>	Up to 500 stroke: $+2_0$ , 501 to 1000 stroke: $+2.4_0$					
<b>Cushion</b>	Air cushion on both ends + Bumper cushion					
<b>Port size</b>	G 1/8	G 1/4	G 1/4	G 3/8	G 3/8	G 1/2
<b>Mounting</b>	Basic, Axial foot, Rod flange, Head flange, Single clevis, Double clevis, Center trunnion					
<b>Non-rotating accuracy</b>	±0.5°		±0.5°		±0.3°	
<b>Allowable rotational torque [N·m]</b>	0.25	0.45	0.64		0.79	

## Maximum Strokes

Bore size [mm]	Maximum stroke*
<b>32</b>	500
<b>40</b>	500
<b>50</b>	600
<b>63</b>	600
<b>80</b>	800
<b>100</b>	800

Intermediate strokes are available.  
 \* Please consult with SMC for longer strokes.

## Accessories

Mounting		Basic	Foot	Rod flange	Head flange	Single clevis	Double clevis	Center trunnion
Standard	Rod end nut	●	●	●	●	●	●	●
	Clevis pin	—	—	—	—	—	●	—
Option	Rod end	●	●	●	●	●	●	●
	Rod clevis	●	●	●	●	●	●	●
	Rod boot	—	—	—	—	—	—	—

\* Do not use a rod end (or floating joint) together with a single clevis with a ball joint (or clevis pivot bracket with a ball joint).  
 \* Refer to pages 10 to 14 for dimensions and part numbers of the accessories.

## ⚠ Precautions

**Be sure to read this before handling. Refer to the back cover for Safety Instructions. For Actuator and Auto Switch Precautions, refer to "Handling Precautions for SMC Products" and the Operation Manual on SMC website, <http://www.smcworld.com>**

Refer to pages 23 to 27 for cylinders with auto switches.

- Auto switch proper mounting position (detection at stroke end) and its mounting height
- Minimum stroke for auto switch mounting
- Auto switch mounting brackets/Part no.
- Operating range

# Series C96K

## Construction

[First angle projection]

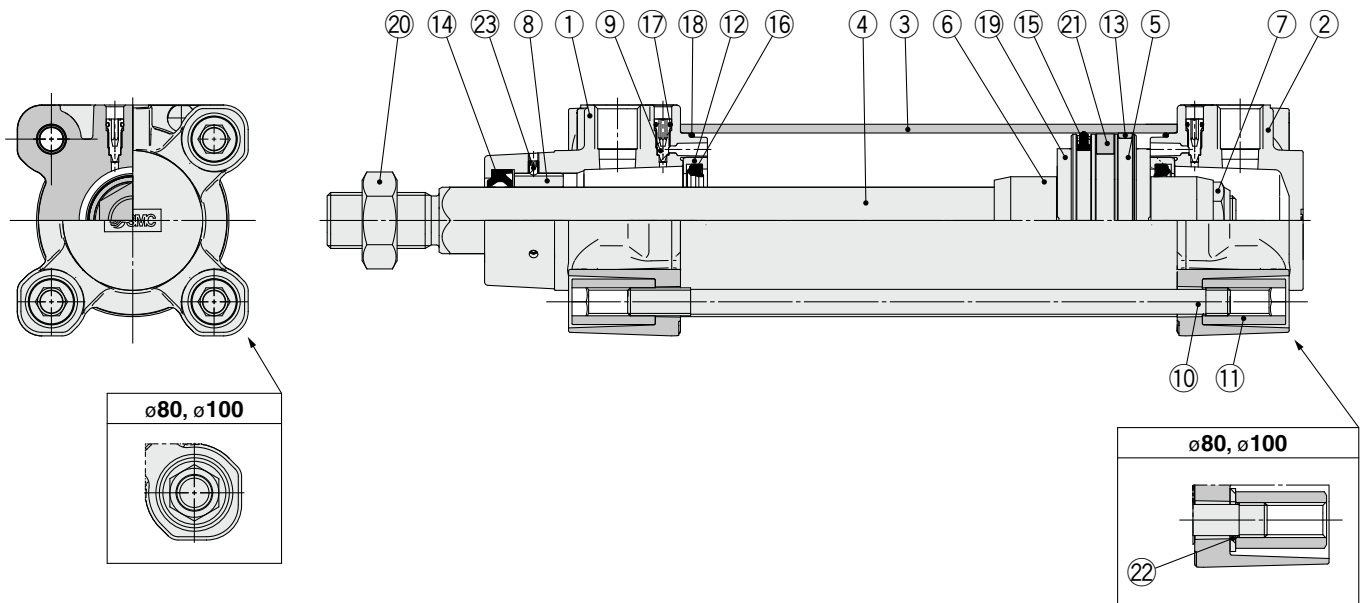

### Component Parts

No.	Description	Material	Q'ty	Note
1	Rod cover	Aluminum die-cast	1	Trivalent chromated
2	Head cover	Aluminum die-cast	1	Trivalent chromated
3	Cylinder tube	Aluminum alloy	1	Hard anodized
4	Piston rod	Stainless steel	1	
5	Piston	Aluminum alloy	1	
6	Cushion ring	Rolled steel	2	Trivalent zinc chromated
7	Piston nut	Rolled steel	1	Trivalent zinc chromated
8	Non-rotating guide	Bearing alloy	1	
9	Cushion valve	Resin	2	
10	Tie-rod	Carbon steel	4	Trivalent zinc chromated
11	Tie-rod nut	Rolled steel	8	Trivalent zinc chromated
12	Cushion seal holder	Aluminum alloy	2	Anodized
13	Wear ring	Resin	1	
14	Rod seal	NBR	1	
15	Piston seal	NBR	1	
16	Cushion seal	Urethane	2	
17	Cushion valve seal	NBR	2	
18	Cylinder tube gasket	NBR	2	
19	Bumper	Urethane	2	
20	Rod end nut	Rolled steel	1	Trivalent zinc chromated
21	Magnet	—	(1)	
22	Flat washer	Steel	8	For ø80, ø100
23	Hexagon socket head set screw	Steel wire	2	Trivalent black zinc chromated

### Replacement Parts/Seal Kit (Single rod)

Bore size [mm]	Kit no.	Contents
32	CK95-32	Kits include items 13 to 16, 18.
40	CK95-40	
50	CK95-50	
63	CK95-63	
80	CK95-80	
100	CK96-100	

\* Seal kits consist of items 13 to 16, 18 and can be ordered by using the seal kit number corresponding to each bore size.

\* The seal kit includes a grease pack (10 g for ø32 to ø50, 20 g for ø63 and ø80, 30 g for ø100).

Order with the following part number when only the grease pack is needed.

**Grease pack part number: GR-S010 (10 g), GR-S-020 (20 g)**

### Seal Kit (Double rod)

Bore size [mm]	Kit no.	Contents
32	CK95W-32	Kits include items 14 to 16, 18.
40	CK95W-40	
50	CK95W-50	
63	CK95W-63	
80	CK95W-80	
100	CK96W-100	

\* Seal kits consist of items 14 to 16, 18 and can be ordered by using the seal kit number corresponding to each bore size.

\* The seal kit includes a grease pack (10 g for ø32 to ø50, 20 g for ø63 and ø80, 30 g for ø100).

Order with the following part number when only the grease pack is needed.

**Grease pack part number: GR-S010 (10 g), GR-S-020 (20 g)**

**Dimensions (Without mounting bracket)**

[First angle projection]

**C96K (D) B** Bore size – Stroke **C**

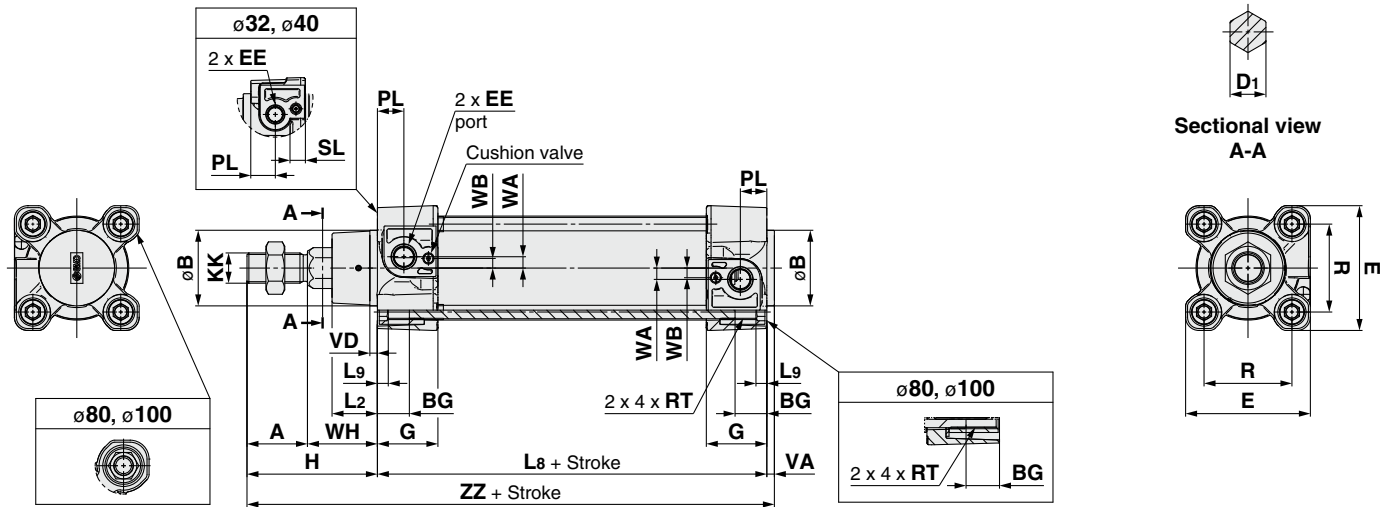

**C96K (D) B** Bore size – Stroke **CW**

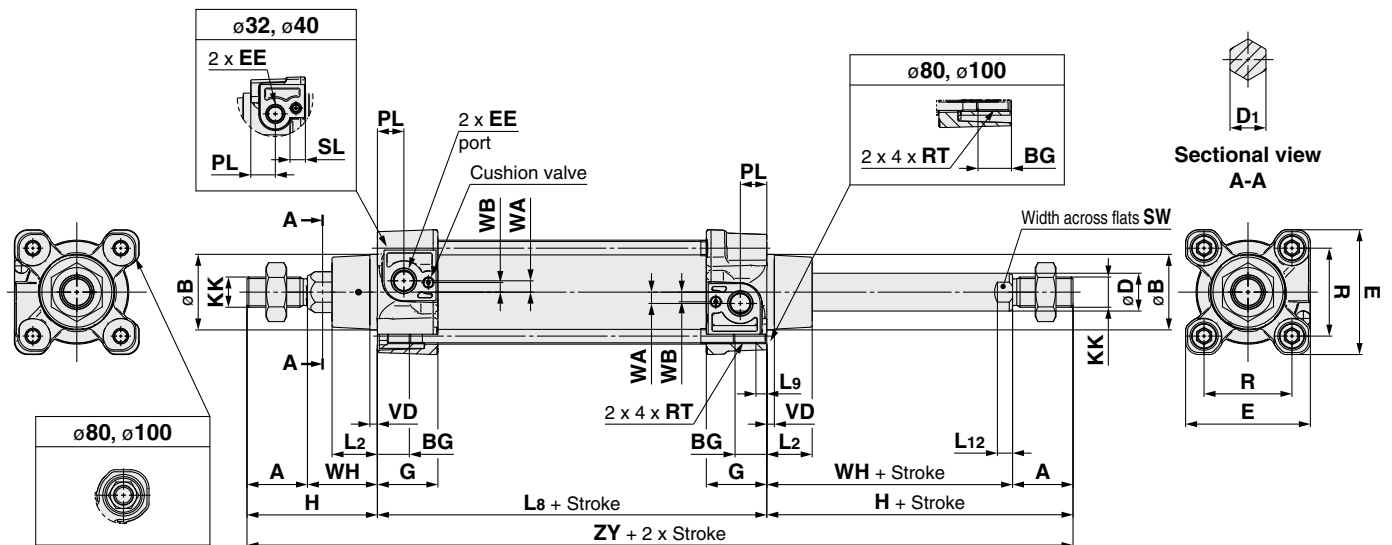

\* Mounting brackets are the same as standard type. Refer to page 10 for details.

Bore size [mm]	Stroke range [mm]	A	øB d11	D1	øD	EE	PL	RT	L12	KK	SW	G	BG	L8	VD	VA	WA	WB	WH	ZZ	ZY	E	R	L2	L9	H	SL
<b>32</b>	Up to 500	22	30	12.2	12	G 1/8	13	M6 x 1	6	M10 x 1.25	10	28.9	16	94	4	4	4	7	26	146	190	47	32.5	15	4	48	8
<b>40</b>	Up to 500	24	35	14.2	16	G 1/4	14	M6 x 1	6.5	M12 x 1.25	13	32.6	16	105	4	4	5	8.9	30	163	213	54	38	17	4	54	8
<b>50</b>	Up to 600	32	40	19	20	G 1/4	14	M8 x 1.25	8	M16 x 1.5	17	32	16	106	4	4	6	5.1	37	179	244	66	46.5	24	5	69	—
<b>63</b>	Up to 600	32	45	19	20	G 3/8	16	M8 x 1.25	8	M16 x 1.5	17	38.6	16	121	4	4	9	6.3	37	194	259	77	56.5	24	5	69	—
<b>80</b>	Up to 800	40	45	23	25	G 3/8	16	M10 x 1.5	10	M20 x 1.5	22	38.4	17	128	4	4	11.5	6	46	218	300	99	72	30	—	86	—
<b>100</b>	Up to 800*	40	55	23	25	G 1/2	18	M10 x 1.5	10	M20 x 1.5	22	42.9	17	138	4	4	17	10	51	233	320	118	89	32	—	91	—

\* Minimum stroke for trunnion mounting: 1 mm for bore size 32 to 80, 5 mm for bore size 100

# ISO (15552) Standard

## Smooth Cylinder Double Acting, Single Rod

# Series C96Y

∅32, ∅40, ∅50, ∅63, ∅80, ∅100



The C96Y series, Smooth Cylinder, ∅125 is the same as the current model. For details, refer to the Web Catalog.

### How to Order

**C96Y** **B** **32** - **100** **C** - [ ]

**With auto switch** **C96YD** **B** **32** - **100** **C** - **M9BW** **S** - [ ]

**Mounting**

<b>B</b>	Basic
<b>L</b>	Axial foot
<b>F</b>	Rod flange
<b>G</b>	Head flange
<b>C</b>	Single clevis
<b>D</b>	Double clevis
<b>T</b>	Center trunnion

\* Mounting brackets are shipped together, (but not assembled). (except center trunnion type)

**Bore size**

<b>32</b>	32 mm
<b>40</b>	40 mm
<b>50</b>	50 mm
<b>63</b>	63 mm
<b>80</b>	80 mm
<b>100</b>	100 mm

**Cylinder stroke [mm]**  
Refer to "Maximum Strokes" on page 20.

**With auto switch**  
(Built-in magnet)

**Made to Order**  
Refer to page 20 for details.

**Number of auto switches**

<b>Nil</b>	2 pcs.
<b>S</b>	1 pc.
<b>3</b>	3 pcs.
<b>n</b>	"n" pcs.

**Auto switch**

<b>Nil</b>	Without auto switch
------------	---------------------

\* For applicable auto switches, refer to the table below.

**Air cushion on both ends + Bumper cushion**

**Applicable Auto Switches**/Refer to the **Web Catalog** or Best Pneumatics for further information on auto switches.

Type	Special function	Electrical entry	Indicator light	Wiring (Output)	Load voltage		Auto switch model		Lead wire length [m]					Pre-wired connector	Applicable load		
					DC	AC	Tie-rod mounting	Band mounting	0.5 (Nil)	1 (M)	3 (L)	5 (Z)	IC circuit		Relay, PLC		
Solid state auto switch	—	Grommet	—	3-wire (NPN)	5 V, 12 V	—	—	<b>M9N</b>	●	●	●	○	○	—	—	—	
				3-wire (PNP)				<b>M9P</b>	●	●	●	○	○				
				2-wire	<b>M9B</b>			●	●	●	○	○					
		3-wire (NPN)		—	<b>G39</b>			—	—	—	—	—					
		2-wire		—	<b>K39</b>			—	—	—	—	—					
		3-wire (NPN)		5 V, 12 V	<b>M9NW</b>			—	●	●	●	○	○				
	3-wire (PNP)	<b>M9PW</b>	—		●	●	●	○	○								
	Diagnostic indication (2-color indication)	Grommet	Yes	24 V	2-wire	12 V	—	<b>M9BW</b>	—	●	●	●	○	○	—	—	
					3-wire (NPN)	5 V, 12 V		<b>M9NA</b> *1	—	○	○	●	○	○			
	Water resistant (2-color indication)	Grommet	—	—	3-wire (PNP)		5 V, 12 V	—	<b>M9PA</b> *1	—	○	○	●	○	○	—	—
					2-wire	<b>M9BA</b> *1			—	○	○	●	○	○			
	With diagnostic output (2-color indication)	Grommet	—	—	4-wire (NPN)	5 V, 12 V	—	<b>F59F</b>	—	●	—	●	○	○	—	—	
2-wire (Non-polar)					—	<b>P4DW</b>		—	—	—	●	●	○				
Reed auto switch	—	Grommet	Yes	3-wire (NPN Equivalent)	—	5 V	—	<b>A96</b>	—	●	—	●	—	—	IC circuit	—	
				No	24 V	12 V	100 V	<b>A93</b>	—	●	●	●	●	—	—	—	—
							100 V or less	<b>A90</b>	—	●	—	●	—	—			
							100 V, 200 V	<b>A54</b>	—	●	—	●	●	—			
		Yes		2-wire	24 V	12 V	200 V or less	<b>A64</b>	—	●	—	●	—	—	—	—	
							—	<b>A33</b>	—	—	—	—	—	—			
		Terminal conduit		—	—	—	100 V, 200 V	—	<b>A34</b>	—	—	—	—	—	—	—	—
								—	<b>A44</b>	—	—	—	—	—	—		
DIN terminal	Yes	—	—	—	—	—	<b>A59W</b>	—	●	—	●	—	—	—	—		
							—	—	—	—	—	—					
Diagnostic indication (2-color indication)	Grommet	—	—	—	—	—	<b>A59W</b>	—	●	—	●	—	—	IC circuit	—		

\*1 Water resistant type auto switches can be mounted on the above models, but in such case SMC cannot guarantee water resistance. Please contact SMC regarding water resistant types with the above model numbers.

\* Lead wire length symbols: 0.5 m ..... Nil (Example) M9NW  
1 m ..... M (Example) M9NWM  
3 m ..... L (Example) M9NWL  
5 m ..... Z (Example) M9NWZ

\* Solid state auto switches marked with "○" are produced upon receipt of order.

\* Since there are other applicable auto switches than listed above, refer to the Best Pneumatics No. 2 for details.

\* For details about auto switches with pre-wired connector, refer to the Best Pneumatics No. 2.

\* The D-A9□/M9□/M9□W/M9□A auto switches are shipped together, (but not assembled). (However, only the auto switch mounting brackets are assembled before shipment.)



Designed with a low sliding resistance of the piston, this air cylinder is ideal for applications such as contact pressure control, which requires smooth movements at low pressure.

Low sliding resistance  
Min. operating pressure –0.01 MPa

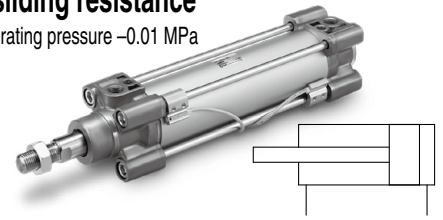

**Sliding resistance** Bi-directional low-friction operation possible.

Pressure can be controlled regardless of its direction.

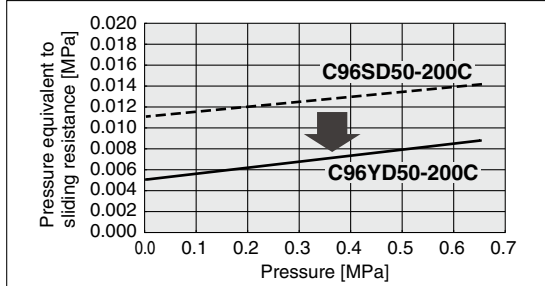

### Application Example

Smooth cylinder combined with precision regulator (e.g. Series IR)

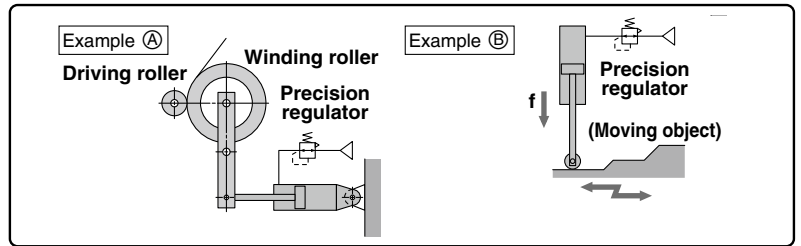

**Made to Order**  
(For details, refer to pages 32 to 41.)

Symbol	Specifications
-XA□	Change of rod end shape
-XC14	Change of trunnion bracket mounting position
-XC7	Tie-rod, tie-rod nut, etc. made of stainless steel
-XC10	Dual stroke cylinder/Double rod type
-XC65	Made of stainless steel (Combination of -XC7 and -XC68)
-XC68	Made of stainless steel (with hard chrome plated piston rod)

Refer to pages 23 to 27 for cylinders with auto switches.

- Auto switch proper mounting position (detection at stroke end) and its mounting height
- Minimum stroke for auto switch mounting
- Auto switch mounting brackets/Part no.
- Operating range

Dimensions are the same as standard type. For details, refer to pages 7 to 9.

### Replacement Parts/Seal Kit

Bore size [mm]	Kit no.	Contents
32	C96Y32-PS	Rod seal 1 pc. Piston seal 1 pc. Cylinder tube gasket 2 pcs. Grease pack (10 g) 1 pc.
40	C96Y40-PS	
50	C96Y50-PS	
63	C96Y63-PS	
80	C96Y80-PS	
100	C96Y100-PS	

\* Seal kits consist of items shown above, and can be ordered by using the seal kit number corresponding to each bore size.

\* Only use the grease recommended by SMC. Order using the following part numbers when only maintenance grease is needed.

Volume	Part no.
5 g	GR-L-005
10 g	GR-L-010
150 g	GR-L-150

### Specifications

Bore size [mm]	32	40	50	63	80	100
<b>Action</b>	Double acting					
<b>Fluid</b>	Air					
<b>Proof pressure</b>	1.05 MPa					
<b>Maximum operating pressure</b>	0.7 MPa					
<b>Minimum operating pressure</b>	0.02 MPa		0.01 MPa			
<b>Ambient and fluid temperature</b>	Without auto switch: –10 to 70°C (No freezing) With auto switch: –10 to 60°C (No freezing)					
<b>Lubrication</b>	Not required (Non-lube)					
<b>Operating piston speed</b>	5 to 500 mm/s					
<b>Allowable stroke tolerance</b>	Up to 500 stroke: $^{+2}_0$ , 501 to 1000 stroke: $^{+2.4}_0$					
<b>Cushion</b>	Bumper					
<b>Port size</b>	G 1/8	G 1/4	G 1/4	G 3/8	G 3/8	G 1/2
<b>Mounting</b>	Basic, Axial foot, Rod flange, Head flange, Single clevis, Double clevis, Center trunnion					
<b>Allowable leakage rate</b>	0.5 L/min (ANR)					

### Maximum Strokes

Bore size [mm]	Maximum stroke*
32	800
40	800
50	1000
63	1000
80	1000
100	1000

Intermediate strokes are available.

\* Please consult with SMC for longer strokes.

### Accessories

Mounting		Basic	Foot	Rod flange	Head flange	Single clevis	Double clevis	Center trunnion
Standard	Rod end nut	●	●	●	●	●	●	●
	Clevis pin	—	—	—	—	—	●	—
Option	Rod end	●	●	●	●	●	●	●
	Rod clevis	●	●	●	●	●	●	●
	Rod boot	—	—	—	—	—	—	—

\* Do not use a rod end (or floating joint) together with a single clevis with a ball joint (or clevis pivot bracket with a ball joint).

\* Refer to pages 10 to 14 for dimensions and part numbers of the accessories.



# Smooth Cylinders Specific Product Precautions 1

Be sure to read this before handling. Refer to the back cover for Safety Instructions. For Actuator and Auto Switch Precautions, refer to “Handling Precautions for SMC Products” and the Operation Manual on SMC website, <http://www.smcworld.com>

## Recommended Pneumatic Circuit

Refer to the diagrams below when controlling speed with the smooth cylinder.

### Warning

#### Horizontal Operation (Speed control)

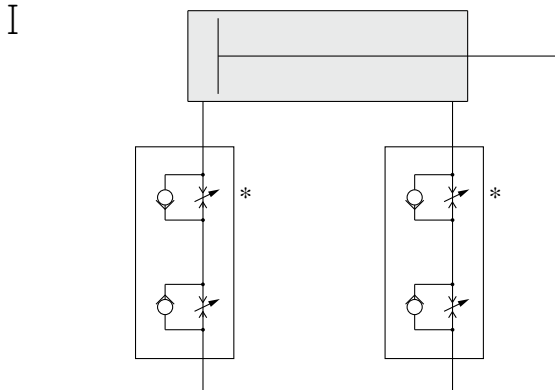

#### Dual speed controller

Speed is controlled by meter-out circuit. Using concurrently the meter-in circuit can alleviate the stick-slip. More stable low speed operation can be achieved than meter-in circuit alone.

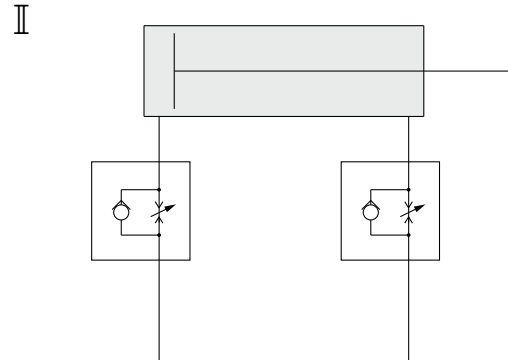

#### Meter-in speed controller

Meter-in speed controllers can reduce lurching while controlling the speed. The two adjustment needles facilitate adjustment.

#### Vertical Operation (Speed control)

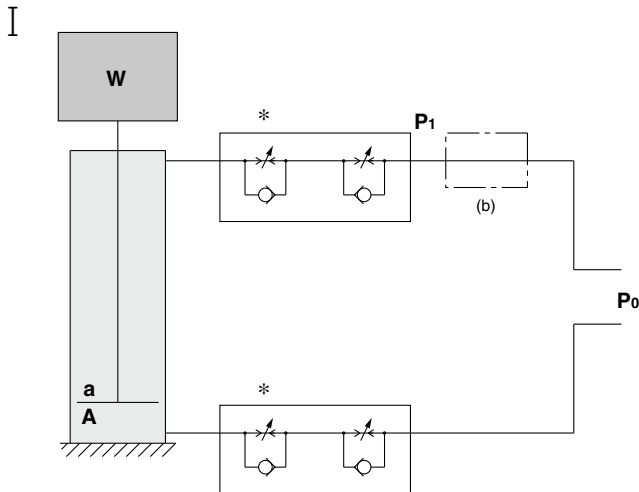

- (1) Speed is controlled by meter-out circuit. Using concurrently the meter-in circuit can alleviate the stick-slip.\*
- (2) Depending on the size of the load, installing a regulator with check valve at position (b) can reduce lurching during descent and operation delay during ascent.  
As a guide,  
when  $W + P_0a > P_0A$ ,  
adjust  $P_1$  to make  $W + P_1a = P_0A$ .

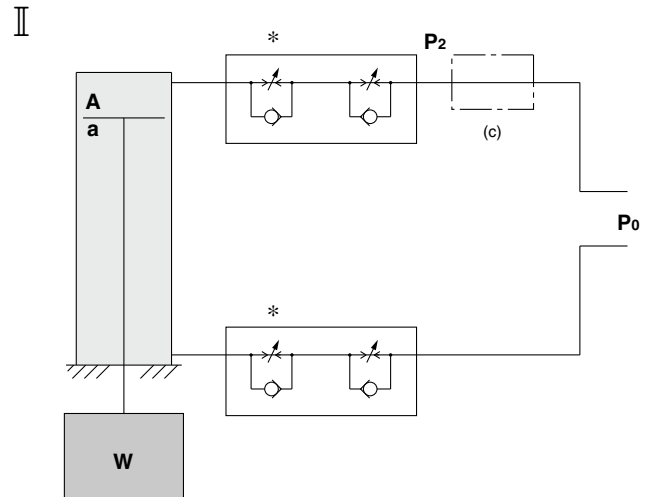

- (1) Speed is controlled by meter-out circuit. Using concurrently the meter-in circuit can alleviate the stick-slip.\*
- (2) Installing a regulator with check valve at position (c) can reduce lurching during descent and operation delay during ascent.  
As a guide,  
adjust  $P_2$  to make  $W + P_2A = P_0a$ .

W: Load [N] P<sub>0</sub>: Operating pressure [MPa] P<sub>1</sub>, P<sub>2</sub>: Reduced pressure [MPa] a: Rod side piston area [mm<sup>2</sup>] A: Head side piston area [mm<sup>2</sup>]



# Smooth Cylinders Specific Product Precautions 2

Be sure to read this before handling. Refer to the back cover for Safety Instructions. For Actuator and Auto Switch Precautions, refer to “Handling Precautions for SMC Products” and the Operation Manual on SMC website, <http://www.smcworld.com>

## Lubrication

### Caution

**1. Operate without lubrication from a pneumatic system lubricator.**

A malfunction may occur when lubricated in this fashion.

**2. Only use the grease recommended by SMC.**

The use of grease other than the specified type can cause a malfunction.

- Order using the following part numbers when only maintenance grease is needed.

#### Grease

Volume	Part no.
5 g	GR-L-005
10 g	GR-L-010
150 g	GR-L-150

**3. Do not wipe out the grease in the sliding part of the air cylinder.**

Wiping grease from the sliding part of the air cylinder forcefully may cause malfunction.

## Air Supply

### Caution

**1. Take measures to prevent pressure fluctuation.**

A malfunction may occur with the fluctuation of pressure.

# Series C96

# Auto Switch Mounting

## Auto Switch Proper Mounting Position (Detection at stroke end) and Its Mounting Height

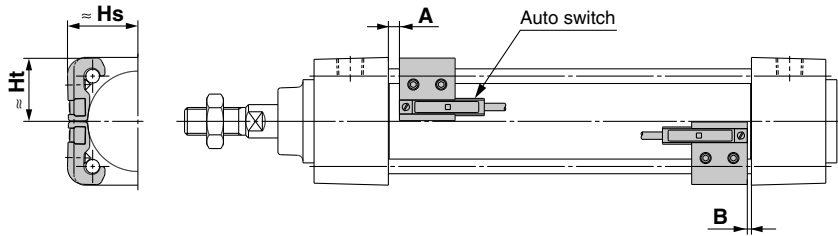

### Auto Switch Proper Mounting Position

[mm]

Auto switch model	D-M9□ D-M9□V D-M9□A		D-A9□ D-A9□V		D-Y59 D-Y69 D-Y7P D-Y7H D-Y7□W D-Y7BA D-Z7□ D-Z80		D-P4DW		D-G39 D-K39 D-A3□ D-A44 D-A5□ D-A6□		D-F5□ D-J59 D-F59F		D-J51		D-A59W		D-F5NT		
	A	B	A	B	A	B	A	B	A	B	A	B	A	B	A	B	A	B	
Bore size																			
32	14	10.5	10	6.5	7.5	4	7	3.5	4	0	10.5	7	10	6.5	8	4.5	15.5	12	
40	14	14	10	10	7.5	7.5	7	7	4	4	10.5	10.5	10	10	8	8	15.5	15.5	
50	15.5	14.5	11.5	10.5	9	8	8.5	7.5	5.5	4.5	12	11	11.5	10.5	9.5	8.5	17	16	
63	16.5	15.5	12.5	11.5	10	9	9.5	8.5	6.5	5.5	13	12	12.5	11.5	10.5	9.5	18	17	
80	21.5	18	17.5	14	15	11.5	14.5	11	11.5	8	18	14.5	17.5	14	15.5	12	23	19.5	
100	21.5	19	17.5	15	15	12.5	14.5	12	11.5	9	18	15.5	17.5	15	15.5	13	23	20.5	

Note) Adjust the auto switch after confirming the operating conditions in the actual setting.

### Auto Switch Mounting Height

[mm]

Auto switch model	D-M9□ D-M9□W D-M9□A D-A9□		D-A9□V		D-M9□V D-M9□WV D-M9□AV		D-A5□ D-A6□ D-A59W		D-F5□ D-J59 D-F59F D-F5□W D-J59W D-F5BA D-F5NT		D-G39 D-K39 D-A3□		D-A44		D-Y59□ D-Y7P D-Y7□W D-Y7BA D-Z7□ D-Z80		D-Y69□ D-Y7PV D-Y7□WV		D-P4DW	
	Hs	Ht	Hs	Ht	Hs	Ht	Hs	Ht	Hs	Ht	Hs	Ht	Hs	Ht	Hs	Ht	Hs	Ht	Hs	Ht
Bore size																				
32	24.5	23	27.5	23	30.5	23	35	24.5	32.5	25	67	27.5	77	27.5	25.5	23	26.5	23	38	31
40	28.5	25.5	31.5	25.5	34	25.5	38.5	27.5	36.5	27.5	71.5	27.5	81.5	27.5	29.5	26	30	26	42	33
50	33.5	31	36	31	38.5	31	43.5	34.5	41	34	77	—	87	—	33.5	31	34.5	31	46.5	39
63	38.5	36	40.5	36	43	36	48.5	39.5	46	39	83.5	—	93.5	—	39	36	40	36	51.5	44
80	46.5	45	49	45	52	45	55	46.5	52.5	46.5	92.5	—	103	—	47.5	45	48.5	45	58	51.5
100	54	53.5	57	53.5	59.5	53.5	62	55	59.5	55	103	—	113.5	—	55.5	53.5	56.5	53.5	65.5	60.5



## Minimum Stroke for Auto Switch Mounting

Auto switch model	Number of auto switches	Support bracket other than center trunnion				
		ø32	ø40	ø50	ø63	ø80, ø100
<b>D-M9</b> □ <b>D-M9</b> □ <b>W</b>	With 1 pc. With 2 pcs. (Different surfaces, Same surface)	10				
	With n pcs.	$10 + 40(n-2)/2$ n = 2, 4, 6, 8...				
<b>D-M9</b> □ <b>V</b> <b>D-M9</b> □ <b>WV</b>	With 1 pc. With 2 pcs. (Different surfaces, Same surface)	10				
	With n pcs.	$10 + 30(n-2)/2$ n = 2, 4, 6, 8...				
<b>D-M9</b> □ <b>A</b>	With 1 pc. With 2 pcs. (Different surfaces, Same surface)	15	10			
	With n pcs.	$15 + 40(n-2)/2$ n = 2, 4, 6, 8...	$10 + 40(n-2)/2$ n = 2, 4, 6, 8...			
<b>D-M9</b> □ <b>AV</b>	With 1 pc. With 2 pcs. (Different surfaces, Same surface)	10				
	With n pcs.	$10 + 30(n-2)/2$ n = 2, 4, 6, 8...				
<b>D-A9</b> □	With 1 pc. With 2 pcs. (Different surfaces, Same surface)	10				
	With n pcs.	$10 + 40(n-2)/2$ n = 2, 4, 6, 8...				
<b>D-A9</b> □ <b>V</b>	With 1 pc. With 2 pcs. (Different surfaces, Same surface)	10				
	With n pcs.	$10 + 30(n-2)/2$ n = 2, 4, 6, 8...				
<b>D-G39</b> <b>D-K39</b> <b>D-A3</b> □	With 2 pcs. (Different surfaces)	35				
	With 2 pcs. (Same surface)	100				
	With n pcs. (Different surfaces)	$35 + 30(n-2)$ n = 2, 3, 4...				
	With n pcs. (Same surface)	$100 + 100(n-2)$ n = 2, 3, 4...				
	With 1 pc.	10				
<b>D-A44</b>	With 2 pcs. (Different surfaces)	35				
	With 2 pcs. (Same surface)	50				
	With n pcs. (Different surfaces)	$35 + 30(n-2)$ n = 2, 3, 4...				
	With n pcs. (Same surface)	$50 + 50(n-2)$ n = 2, 3, 4...				
	With 1 pc.	10				
<b>D-A5</b> □ <b>D-A6</b> □	With 1 pc. With 2 pcs. (Different surfaces, Same surface)	15			10	
	With n pcs. (Same surface)	$15 + 55(n-2)/2$ n = 2, 4, 6, 8...			$10 + 55(n-2)/2$ n = 2, 4, 6, 8...	
<b>D-A59W</b>	With 2 pcs. (Different surfaces, Same surface)	20			15	
	With n pcs. (Same surface)	$20 + 55(n-2)/2$ n = 2, 4, 6, 8...			$15 + 55(n-2)/2$ n = 2, 4, 6, 8...	
	With 1 pc.	15			25	
<b>D-F5</b> □ <b>D-J59</b> <b>D-F5</b> □ <b>W</b> <b>D-J59W</b> <b>D-F5BA</b> <b>D-F59F</b>	With 2 pcs. (Different surfaces, Same surface)	15				
	With n pcs. (Same surface)	$15 + 55(n-2)/2$ n = 2, 4, 6, 8...				
	With 1 pc.	10				
<b>D-F5NT</b>	With 2 pcs. (Different surfaces, Same surface)	15			20	
	With n pcs. (Same surface)	$15 + 55(n-2)/2$ n = 2, 4, 6, 8...			$20 + 55(n-2)/2$ n = 2, 4, 6, 8...	
	With 1 pc.	10			20	
<b>D-Y59</b> □ <b>D-Y7P</b> <b>D-Y7H</b> <b>D-Y7</b> □ <b>W</b> <b>D-Z7</b> □ <b>D-Z80</b>	With 1 pc. With 2 pcs. (Different surfaces, Same surface)	15	10			
	With n pcs.	$15 + 40(n-2)/2$ n = 2, 4, 6, 8...	$10 + 40(n-2)/2$ n = 2, 4, 6, 8...			
<b>D-Y69</b> □ <b>D-Y7PV</b> <b>D-Y7</b> □ <b>WV</b>	With 1 pc. With 2 pcs. (Different surfaces, Same surface)	10				
	With n pcs.	$10 + 30(n-2)/2$ n = 2, 4, 6, 8...				
<b>D-Y7BA</b>	With 1 pc. With 2 pcs. (Different surfaces, Same surface)	20				
	With n pcs.	$20 + 45(n-2)/2$ n = 2, 4, 6, 8...				
<b>D-P4DW</b>	With 1 pc. With 2 pcs. (Different surfaces, Same surface)	15				
	With n pcs.	$15 + 65(n-2)/2$ n = 2, 4, 6, 8...				

Note) n = 3, 4, 5...

## Minimum Stroke for Auto Switch Mounting

Auto switch model	Number of auto switches	Center trunnion					
		ø32	ø40	ø50	ø63	ø80	ø100
D-M9□ D-M9□W	With 1 pc. With 2 pcs. (Different surfaces, Same surface)	75			85	90	95
	With n pcs.	$75 + 40(n-4)/2$ n = 4, 8, 12, 16...			$85 + 40(n-4)/2$ n = 4, 8, 12, 16...	$90 + 40(n-4)/2$ n = 4, 8, 12, 16...	$95 + 40(n-4)/2$ n = 4, 8, 12, 16...
D-M9□V D-M9□WV	With 1 pc. With 2 pcs. (Different surfaces, Same surface)	50	55		60	65	70
	With n pcs.	$50 + 30(n-4)/2$ n = 4, 8, 12, 16...	$55 + 30(n-4)/2$ n = 4, 8, 12, 16...		$60 + 30(n-4)/2$ n = 4, 8, 12, 16...	$65 + 30(n-4)/2$ n = 4, 8, 12, 16...	$70 + 30(n-4)/2$ n = 4, 8, 12, 16...
D-M9□A	With 1 pc. With 2 pcs. (Different surfaces, Same surface)	80			85	95	100
	With n pcs.	$80 + 40(n-2)/2$ n = 4, 8, 12, 16...			$85 + 40(n-2)/2$ n = 4, 8, 12, 16...	$95 + 40(n-2)/2$ n = 4, 8, 12, 16...	$100 + 40(n-2)/2$ n = 4, 8, 12, 16...
D-M9□AV	With 1 pc. With 2 pcs. (Different surfaces, Same surface)	55			65	70	75
	With n pcs.	$55 + 30(n-2)/2$ n = 4, 8, 12, 16...			$65 + 30(n-2)/2$ n = 4, 8, 12, 16...	$70 + 30(n-2)/2$ n = 4, 8, 12, 16...	$75 + 30(n-2)/2$ n = 4, 8, 12, 16...
D-A9□	With 1 pc. With 2 pcs. (Different surfaces, Same surface)	70	75		80	85	95
	With n pcs.	$70 + 40(n-4)/2$ n = 4, 8, 12, 16...	$75 + 40(n-4)/2$ n = 4, 8, 12, 16...		$80 + 40(n-4)/2$ n = 4, 8, 12, 16...	$85 + 40(n-4)/2$ n = 4, 8, 12, 16...	$95 + 40(n-4)/2$ n = 4, 8, 12, 16...
D-A9□V	With 1 pc. With 2 pcs. (Different surfaces, Same surface)	45	50		55	60	70
	With n pcs.	$45 + 30(n-4)/2$ n = 4, 8, 12, 16...	$50 + 30(n-4)/2$ n = 4, 8, 12, 16...		$55 + 30(n-4)/2$ n = 4, 8, 12, 16...	$60 + 30(n-4)/2$ n = 4, 8, 12, 16...	$70 + 30(n-4)/2$ n = 4, 8, 12, 16...
D-G39 D-K39 D-A3□	With 2 pcs. (Different surfaces)	60	65		75	80	85
	With 2 pcs. (Same surface)	90	95		100	105	110
	With n pcs. (Different surfaces)	$60 + 30(n-2)$ n = 2, 4, 6, 8...	$65 + 30(n-2)$ n = 2, 4, 6, 8...		$75 + 30(n-2)$ n = 2, 4, 6, 8...	$80 + 30(n-2)$ n = 2, 4, 6, 8...	$85 + 30(n-2)$ n = 2, 4, 6, 8...
	With n pcs. (Same surface)	$90 + 100(n-2)$ n = 2, 4, 6, 8...	$95 + 100(n-2)$ n = 2, 4, 6, 8...		$100 + 100(n-2)$ n = 2, 4, 6, 8...	$105 + 100(n-2)$ n = 2, 4, 6, 8...	$110 + 100(n-2)$ n = 2, 4, 6, 8...
	With 1 pc.	60	65		75	80	85
D-A44	With 2 pcs. (Different surfaces)	70			75	80	85
	With 2 pcs. (Same surface)	70			75	80	85
	With n pcs. (Different surfaces)	$70 + 30(n-2)$ n = 2, 4, 6, 8...			$75 + 30(n-2)$ n = 2, 4, 6, 8...	$80 + 30(n-2)$ n = 2, 4, 6, 8...	$85 + 30(n-2)$ n = 2, 4, 6, 8...
	With n pcs. (Same surface)	$70 + 50(n-2)$ n = 2, 4, 6, 8...			$75 + 50(n-2)$ n = 2, 4, 6, 8...	$80 + 50(n-2)$ n = 2, 4, 6, 8...	$85 + 50(n-2)$ n = 2, 4, 6, 8...
	With 1 pc.	70			75	80	85
D-A5□ D-A6□	With 1 pc. With 2 pcs. (Different surfaces, Same surface)	60		80	95	105	110
	With n pcs. (Same surface)	$60 + 55(n-4)/2$ n = 4, 8, 12, 16...		$80 + 55(n-4)/2$ n = 4, 8, 12, 16...	$95 + 55(n-4)/2$ n = 4, 8, 12, 16...	$105 + 55(n-4)/2$ n = 4, 8, 12, 16...	$110 + 55(n-4)/2$ n = 4, 8, 12, 16...
D-A59W	With 2 pcs. (Different surfaces, Same surface)	60	70	85	105	110	115
	With n pcs. (Same surface)	$60 + 55(n-4)/2$ n = 4, 8, 12, 16...	$70 + 55(n-4)/2$ n = 4, 8, 12, 16...	$85 + 55(n-4)/2$ n = 4, 8, 12, 16...	$105 + 55(n-4)/2$ n = 4, 8, 12, 16...	$110 + 55(n-4)/2$ n = 4, 8, 12, 16...	$115 + 55(n-4)/2$ n = 4, 8, 12, 16...
	With 1 pc.	60	70	85	105	110	115
D-F5□ D-J59 D-F5□W D-J59W D-F5BA D-F59F	With 2 pcs. (Different surfaces, Same surface)	90	95		100	110	115
	With n pcs. (Same surface)	$90 + 55(n-4)/2$ n = 4, 8, 12, 16...	$95 + 55(n-4)/2$ n = 4, 8, 12, 16...		$100 + 55(n-4)/2$ n = 4, 8, 12, 16...	$110 + 55(n-4)/2$ n = 4, 8, 12, 16...	$115 + 55(n-4)/2$ n = 4, 8, 12, 16...
	With 1 pc.	90	95		100	110	115
D-F5NT	With 2 pcs. (Different surfaces, Same surface)	100	105		110	120	125
	With n pcs. (Same surface)	$100 + 55(n-4)/2$ n = 4, 8, 12, 16...	$105 + 55(n-4)/2$ n = 4, 8, 12, 16...		$110 + 55(n-4)/2$ n = 4, 8, 12, 16...	$120 + 55(n-4)/2$ n = 4, 8, 12, 16...	$125 + 55(n-4)/2$ n = 4, 8, 12, 16...
	With 1 pc.	100	105		110	120	125
D-Y59□ D-Y7P D-Y7H D-Y7□W D-Z7□ D-Z80	With 1 pc. With 2 pcs. (Different surfaces, Same surface)	75	80		85	95	100
	With n pcs. (Same surface)	$75 + 40(n-4)/2$ n = 4, 8, 12, 16...	$80 + 40(n-4)/2$ n = 4, 8, 12, 16...		$85 + 40(n-4)/2$ n = 4, 8, 12, 16...	$95 + 40(n-4)/2$ n = 4, 8, 12, 16...	$100 + 40(n-4)/2$ n = 4, 8, 12, 16...
D-Y69□ D-Y7PV D-Y7□WV	With 1 pc. With 2 pcs. (Different surfaces, Same surface)	55			60	70	75
	With n pcs. (Same surface)	$55 + 30(n-4)/2$ n = 4, 8, 12, 16...			$60 + 30(n-4)/2$ n = 4, 8, 12, 16...	$70 + 30(n-4)/2$ n = 4, 8, 12, 16...	$75 + 30(n-4)/2$ n = 4, 8, 12, 16...
D-Y7BA	With 1 pc. With 2 pcs. (Different surfaces, Same surface)	85	90		100	105	110
	With n pcs. (Same surface)	$85 + 45(n-4)/2$ n = 4, 8, 12, 16...	$90 + 45(n-4)/2$ n = 4, 8, 12, 16...		$100 + 45(n-4)/2$ n = 4, 8, 12, 16...	$105 + 45(n-4)/2$ n = 4, 8, 12, 16...	$110 + 45(n-4)/2$ n = 4, 8, 12, 16...
D-P4DW	With 1 pc. With 2 pcs. (Different surfaces, Same surface)	110			115	125	130
	With n pcs. (Same surface)	$110 + 65(n-4)/2$ n = 4, 8, 12, 16...			$115 + 65(n-4)/2$ n = 4, 8, 12, 16...	$125 + 65(n-4)/2$ n = 4, 8, 12, 16...	$130 + 65(n-4)/2$ n = 4, 8, 12, 16...

Note) n = 3, 4, 5...

## Auto Switch Mounting Brackets/Part No.

Auto switch model	Bore size [mm]					
	ø32	ø40	ø50	ø63	ø80	ø100
D-M9□/M9□V D-M9□W/M9□WV D-M9□A/M9□AV D-A9□/A9□V	BMB5-032	BMB5-032	BA7-040	BA7-040	BA7-063	BA7-063
D-G39/K39 D-A3□/A44	BMB2-032	BMB2-040	BMB1-050	BMB1-063	BMB1-080	BMB1-100
D-F5□/J59 D-F5□W/J59W D-F59F D-F5BA D-F5NT D-A5□/A6□ D-A59W	BT-03	BT-03	BT-05	BT-05	BT-06	BT-06
D-P4DW	BMB3T-040	BMB3T-040	BMB3T-050	BMB3T-050	BMB3T-080	BMB3T-080
D-Y59□/Y69□ D-Y7P/Y7PV D-Y7□W D-Y7□WV D-Y7BA D-Z7□/Z80	BMB4-032	BMB4-032	BMB4-050	BMB4-050	BA4-063	BA4-063

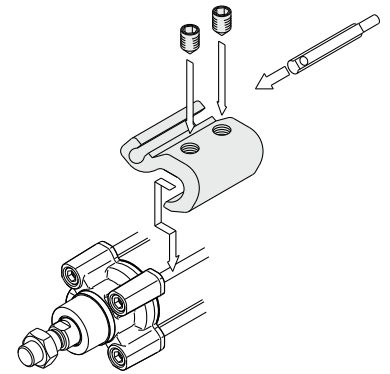

• Mounting example for D-A9□(V), M9□(V), M9□W(V), M9□A(V)

### [Stainless Steel Mounting Screw]

The following stainless steel mounting screw kit (including set screws) is available. Use it in accordance with the operating environment. (Since the auto switch mounting bracket is not included, order it separately.)

BBA1: For D-A5/A6/F5/J5

Note 1) For details on BBA1, refer to the **WEB catalog** or the Best Pneumatics No. 2.

The D-F5BA auto switch is set on the cylinder with the stainless steel screws above when shipped from factory.

When only an auto switch is shipped independently, the BBA1 is attached.

Note 2) When using the D-M9□A(V) or Y7BA, please do not use the iron set screws included with the auto switch mounting bracket (BMB5-032, BA7-□□□, BMB4-□□□, BA4-□□□) shown above, instead order the set of stainless steel set screws (BBA1), and please use the stainless steel set screws (M4 x 6 L) included in BBA1.

## Operating Range

Auto switch model	[mm]					
	32	40	50	63	80	100
D-M9□/M9□V D-M9□W/M9□WV D-M9□A/M9□AV	4	4.5	5	6	6	6
D-A9□/A9□V	7	7.5	8.5	9.5	9.5	10.5
D-Y59□/Y69□ D-Y7P/Y7□V D-Y7□W/Y7□WV D-Y7BA	5.5	5.5	7	7.5	6.5	5.5
D-Z7□/Z80	7.5	8.5	7.5	9.5	9.5	10.5
D-F5□/J59 D-F5□W/J59W D-F5BA/F5NT D-F59F	3.5	4	4	4.5	4.5	4.5
D-A5□/A6□	9	9	10	11	11	11
D-A59W	13	13	13	14	14	15
D-G39/K39	9	9	9	10	10	11
D-A3□/A44	9	9	10	11	11	11
D-P4DW	4	4	4	4.5	4	4.5

\* Values which include hysteresis are for guideline purposes only, they are not a guarantee (assuming approximately ±30% dispersion) and may change substantially depending on the ambient environment.

# Series C96

Other than the applicable auto switches listed in “How to Order”, the following auto switches are mountable.

Refer to the **WEB catalog** or the Best Pneumatics No. 2 for the detailed specifications.

Type	Part no.	Electrical entry	Features
Sold state	D-M9NV, M9PV, M9BV	Grommet (Perpendicular)	—
	D-Y69A, Y69B, Y7PV		—
	D-M9NWV, M9PWV, M9BWW		Diagnostic indication (2-color indication)
	D-Y7NWV, Y7PWV, Y7BWW		Water resistant (2-color indication)
	D-M9NAV, M9PAV, M9BAV		—
	D-Y59A, Y59B, Y7P		Grommet (In-line)
	D-F59, F5P, J59	Diagnostic indication (2-color indication)	
	D-Y7NW, Y7PW, Y7BW	Water resistant (2-color indication)	
	D-F59W, F5PW, J59W	With timer	
	D-F5BA, Y7BA	Magnetic field resistant (2-color indication)	
	D-F5NT	—	
	D-P5DW	—	
	D-A93V, A96V	Grommet (Perpendicular)	
	D-A90V	Grommet (In-line)	—
D-A67, Z80	—		
D-A53, A56, Z73, Z76	—		

\* Normally closed (NC = b contact) solid state auto switches (D-F9G/F9H/Y7G/Y7H) are also available.

For details, refer to the **WEB catalog** or the Best Pneumatics No. 2.

\* With pre-wired connector is also available for solid state auto switches. For details, refer to the **WEB catalog** or the Best Pneumatics No. 2.

# Series C96

# How to Mount and Move the Auto Switch

## Mounting Bracket Tie-rod Mounting Type

### <Applicable Auto Switch>

- Solid state switch ... D-M9N(V), D-M9P(V), D-M9B(V)  
 D-M9NW(V), D-M9PW(V), D-M9BW(V)  
 D-M9NA(V), D-M9PA(V), D-M9BA(V)  
 Reed switch ..... D-A90(V), A93(V), A96(V)

### How to Mount and Move the Auto Switch

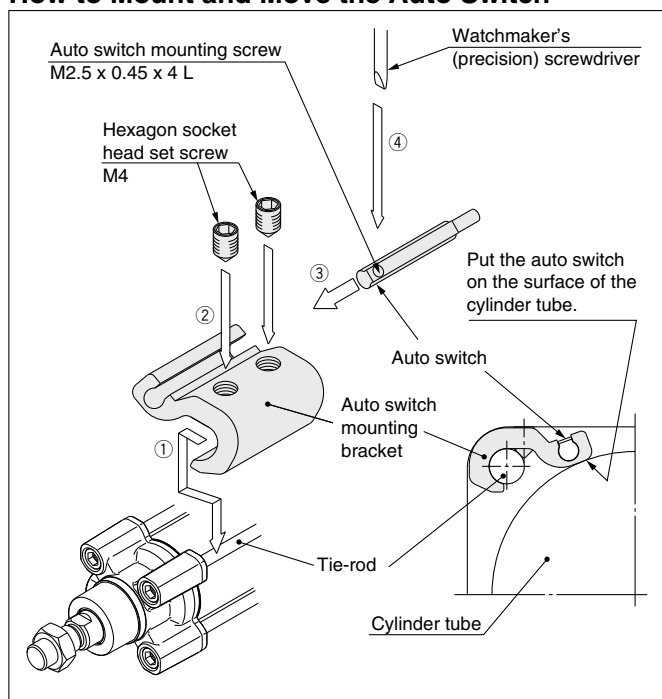

1. Fix it to the detecting position with a set screw by installing an auto switch mounting bracket in cylinder tie-rod and letting the bottom surface of an auto switch mounting bracket contact the cylinder tube firmly.
2. Fix it to the detecting position with a set screw (M4). (Use a hexagon wrench.)
3. Fit an auto switch into the auto switch mounting groove to set it roughly to the mounting position for an auto switch.
4. After confirming the detecting position, tighten up the mounting screw (M2.5 x 0.45 x 4 L) attached to an auto switch, and secure the auto switch.
5. When changing the detecting position, carry out in the state of 3.

- Note 1) To protect auto switches, ensure that main body of an auto switch should be embedded into auto switch mounting groove with a depth of 15 mm or more.  
 Note 2) Set the tightening torque of a hexagon socket head set screw (M4) to be 1.0 to 1.2 N·m.  
 Note 3) When tightening an auto switch mounting screw (M2.5), use a watchmaker's screwdriver with a grip diameter of 5 to 6 mm. Also, set the tightening torque to be 0.05 to 0.15 N·m. As a guide, turn 90° from the position where it comes to feel tight.

### Auto Switch Mounting Bracket Part No. (Including Bracket, Set Screw)

Applicable bore size [mm]					
32	40	50	63	80	100
BMB5-032	BMB5-032	BA7-040	BA7-040	BA7-063	BA7-063

- Note 1) When using the D-M9□A(V), please order stainless steel screw set BBA1 separately (page 26), and use the stainless steel set screws, after selecting set screws of the appropriate length for the cylinder series—as shown in the table above.  
 Note 2) Color or gloss differences in the metal surfaces have no effect on metal performance. The special properties of the chromate (trivalent) applied to the main body of the auto switch mounting bracket for BA7-□ and BMB5-□ result in differences in coloration depending on the production lot, but these have no adverse impact on corrosion resistance.

### <Applicable Auto Switch>

- Solid state switch ... D-G39, D-K39  
 Reed switch ..... D-A33, D-A34, D-A44

### How to Mount and Move the Auto Switch

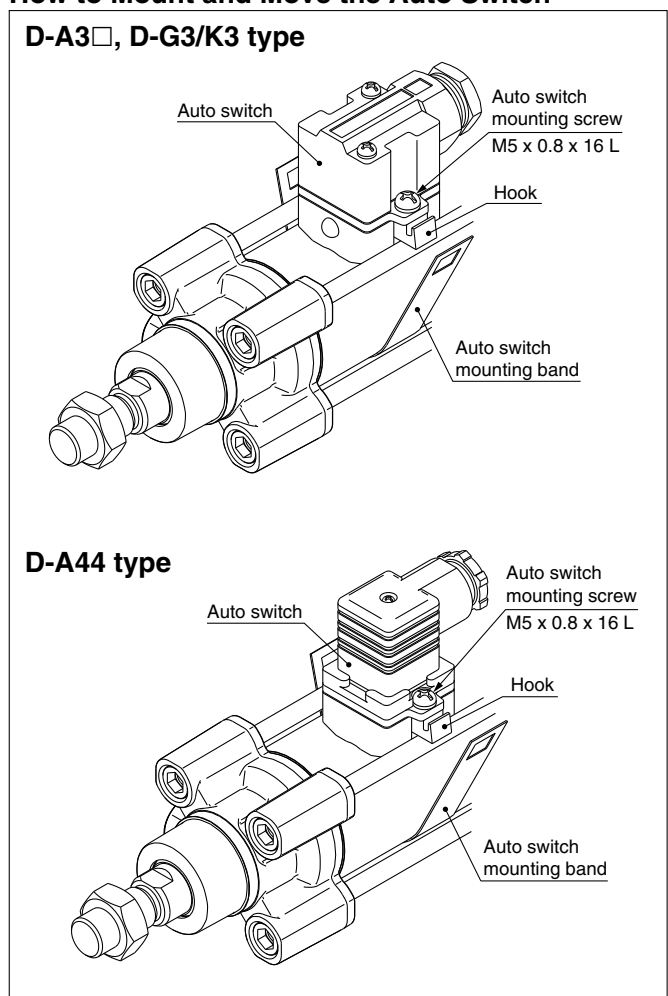

#### D-A3□, D-G3/K3 type

#### D-A44 type

1. Loosen the auto switch mounting screws at both sides to pull down the hook.
2. Put an auto switch mounting band on the cylinder tube and set it at the auto switch mounting position, and then hook the band.
3. Screw lightly the auto switch mounting screw (M5 x 0.8 x 16 L).
4. Set the whole body to the detecting position by sliding, tighten the mounting screw (M5 x 0.8 x 16 L) to secure the auto switch. (The tightening torque should be about 2 to 3 N·m.)
5. When changing the detecting position, carry out in the state of 3.

### Auto Switch Mounting Bracket Part No. (Band)

Applicable bore size [mm]					
32	40	50	63	80	100
BMB2-032	BMB2-040	BMB1-050	BMB1-063	BMB1-080	BMB1-100

## Mounting Bracket Tie-rod Mounting Type

<Applicable Auto Switch>  
Solid state switch ... D-P4DW

### How to Mount and Move the Auto Switch

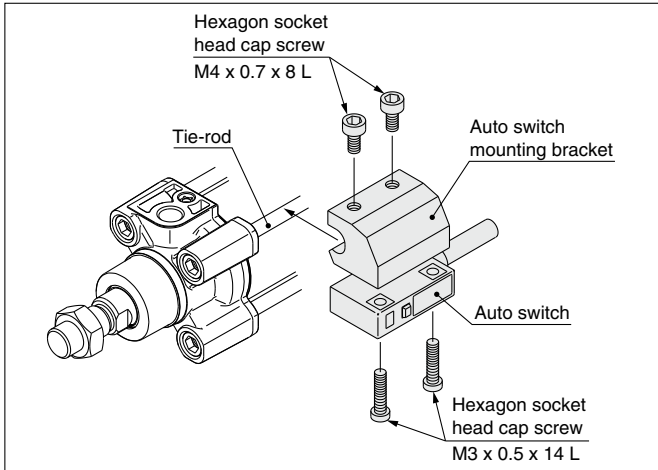

1. Slightly screw the hexagon socket head cap screw (M4 x 0.7 x 8 L) into the M4 tapped portion of auto switch mounting bracket. (2 locations) Use caution that the tip of the hexagon socket head cap screw should not stick out to the concave portion of auto switch mounting bracket.
2. Put a hexagon socket head cap screw (M3 x 0.5 x 14 L) through the auto switch's through-hole (2 locations), and then push it down into the M3 tapped part on the auto switch mounting bracket while turning it lightly.
3. Place the concave part of the auto switch mounting bracket into the cylinder tie-rod, and slide the auto switch mounting bracket in order to set roughly to the detecting position.
4. After reconfirming the detecting position, tighten the M3 mounting screw to secure the auto switch by making the bottom face of auto switch attached to the cylinder tube. (Tightening torque of M3 screw should be 0.5 to 0.7 N·m.)
5. Tighten up M4 screw of auto switch mounting bracket to secure the auto switch mounting bracket. (Ensure that tightening torque of M4 screw should be set 1.0 to 1.2 N·m.)

### Auto Switch Mounting Bracket Part No. (Including Bracket, Screw)

Applicable bore size [mm]					
32	40	50	63	80	100
BMB3T-040	BMB3T-040	BMB3T-050	BMB3T-050	BMB3T-080	BMB3T-080

<Applicable Auto Switch>  
Solid state switch ... D-Y59<sup>A</sup><sub>B</sub>, Y69<sup>A</sup><sub>B</sub>, D-Y7P(V)  
D-Y7NW(V), Y7PW(V), Y7BW(V)  
D-Y7BA  
Reed switch ..... D-Z73, Z76, Z80

### How to Mount and Move the Auto Switch

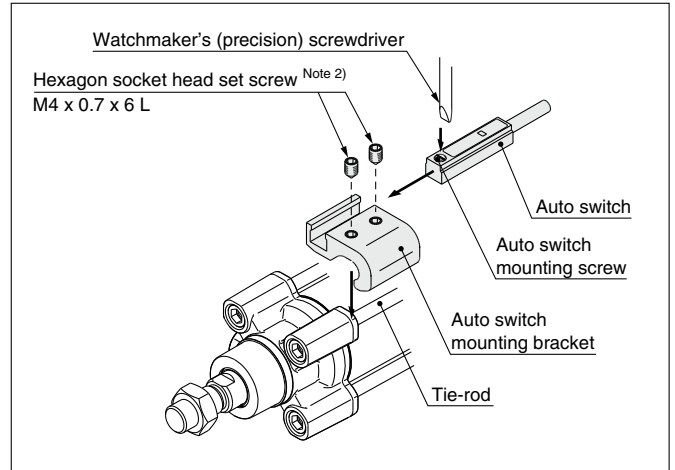

**Note 1) When tightening an auto switch mounting screw, use a watchmaker's screwdriver with a handle diameter of 5 to 6 mm. Also, set the tightening torque to be 0.05 to 0.1 N·m. As a guide, turn 90° from the position where it comes to feel tight. Set the tightening torque of a hexagon socket head set screw (M4 x 0.7 x 6 L) to be 1.0 to 1.2 N·m.**

1. Fix it to the detecting position with a set screw by installing an auto switch mounting bracket in cylinder tie-rod and letting the bottom surface of an auto switch mounting bracket contact the cylinder tube firmly. (Use a hexagon wrench.)
2. Fit an auto switch into the auto switch mounting groove to set it roughly to the mounting position for an auto switch.
3. After confirming the detecting position, tighten up the mounting screw attached to an auto switch, and secure the auto switch.
4. When changing the detecting position, carry out in the state of 2.

\* To protect auto switches, ensure that main body of an auto switch should be embedded into auto switch mounting groove with a depth of 15 mm or more.

### Auto Switch Mounting Bracket Part No. (Including Bracket, Set Screw)

Applicable bore size [mm]					
32	40	50	63	80	100
BMB4-032	BMB4-032	BMB4-050	BMB4-050	BA4-063	BA4-063

Note 2) When using the D-Y7BA, please order stainless steel screw set BBA1 separately (page 26), and use the stainless steel set screws, after selecting set screws of the appropriate length for the cylinder series — as shown in the table above.

## Mounting Bracket Tie-rod Mounting Type

### <Applicable Auto Switch>

- Solid state switch ...** D-F59, D-F5P  
 D-J59, D-F5BA  
 D-F59W, D-F5PW, D-J59W  
 D-F59F, D-F5NT
- Reed switch .....** D-A53, D-A54, D-A56, D-A64, D-A67  
 D-A59W

1. Fix the auto switch on the auto switch mounting bracket with the auto switch mounting screw (M4) and install the set screw (M4).
2. Fit the auto switch mounting bracket into the cylinder tie-rod and then fix the auto switch at the detecting position with a set screw (M4).  
 (Be sure to put the auto switch on the surface of cylinder tube.) (Use a hexagon wrench.)
3. When changing the detecting position, loosen the set screw to move the auto switch and then re-fix the auto switch on the cylinder tube.  
 (Tightening torque of M4 screw should be 1.0 to 1.2 N·m.)

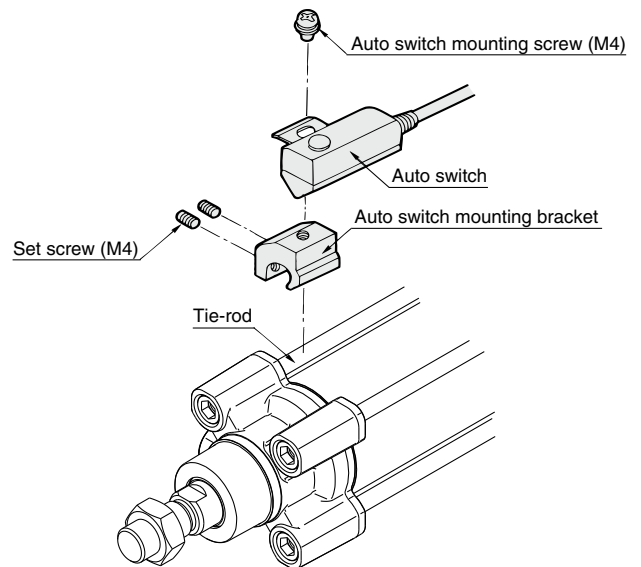

### Auto Switch Mounting Bracket Part No. (Including Bracket, Screw, Set Screw)

Applicable bore size [mm]					
32	40	50	63	80	100
BT-03	BT-03	BT-05	BT-05	BT-06	BT-06

The following stainless steel mounting screw kit (including set screws) is available. Use it in accordance with the operating environment. (Since the auto switch mounting bracket is not included, order it separately.)

BBA1: For D-A5/A6/F5/J5

The D-F5BA auto switch is set on the cylinder with the stainless steel screws above when shipped from factory.

When only an auto switch is shipped independently, the BBA1 is attached.

### Stainless Steel Mounting Screw Set

Part no.	Contents				Applicable auto switch mounting bracket part no.	Applicable auto switch
	No.	Description	Size	Q'ty		
<b>BBA1</b>	1	Auto switch mounting screw	M4 x 0.7 x 8 L	1	BT-□□	D-A5, A6 D-F5, J5
	2	Set screw	M4 x 0.7 x 6 L	2	BT-03, BT-04, BT-05 BT-06, BT-08, BT-12	D-Z7, Z8 D-Y5, Y6, Y7
					BMB5-032	D-A9
					BA7-040, BA7-063, BA7-080	D-M9
	3	Set screw	M4 x 0.7 x 8 L	2	BT-16, BT-18A, BT-20	D-A5, A6 D-F5, J5
					BS4-125, BS4-160 BS4-180, BS4-200	D-Z7, Z8 D-Y5, Y6, Y7
BS5-125, BS5-160 BS5-180, BS5-200					D-A9 D-M9	

Note) Use the set screw after selecting the appropriate length for the auto switch mounting bracket.  
 (Example) When using the BA7-040, select the 6 L type. 8 L type is not required.

# Prior to Use

## Auto Switch Connection and Example

### Sink Input Specifications

#### 3-wire, NPN

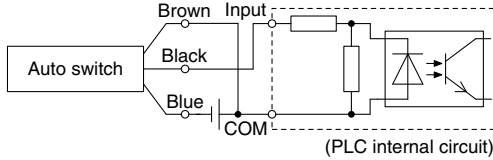

#### 2-wire

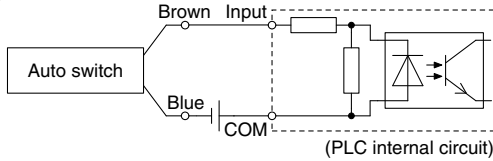

### Source Input Specifications

#### 3-wire, PNP

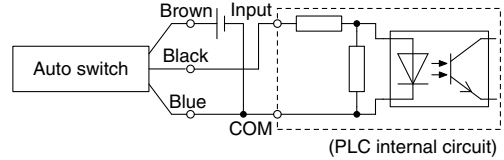

#### 2-wire

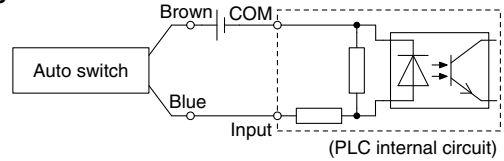

Connect according to the applicable PLC input specifications, as the connection method will vary depending on the PLC input specifications.

### Example of AND (Series) and OR (Parallel) Connection

\* When using solid state auto switches, ensure the application is set up so the signals for the first 50 ms are invalid.

#### 3-wire AND connection for NPN output

(Using relays)

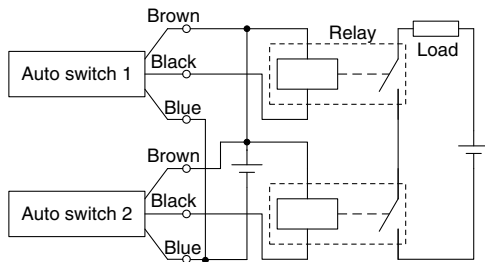

(Performed with auto switches only)

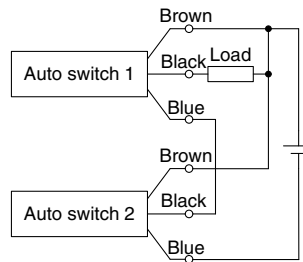

#### 3-wire OR connection for NPN output

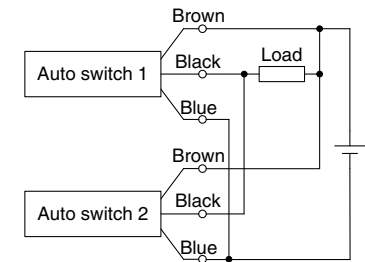

#### 3-wire AND connection for PNP output

(Using relays)

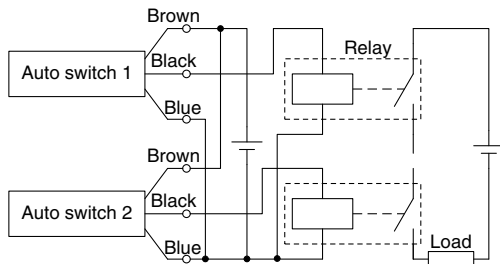

(Performed with auto switches only)

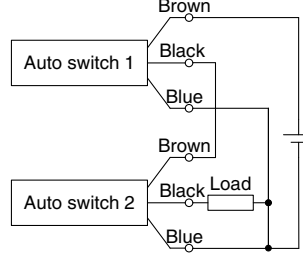

#### 3-wire OR connection for PNP output

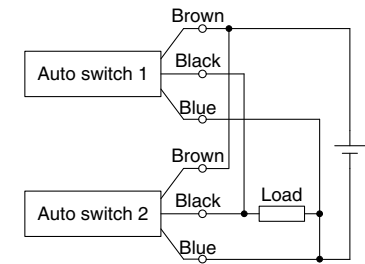

#### 2-wire AND connection

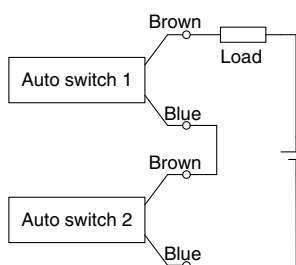

When two auto switches are connected in series, a load may malfunction because the load voltage will decline when in the ON state. The indicator lights will light up when both of the auto switches are in the ON state. Auto switches with load voltage less than 20 V cannot be used.

$$\begin{aligned} \text{Load voltage at ON} &= \text{Power supply voltage} - \\ &\quad \text{Residual voltage} \times 2 \text{ pcs.} \\ &= 24 \text{ V} - 4 \text{ V} \times 2 \text{ pcs.} \\ &= 16 \text{ V} \end{aligned}$$

Example: Power supply is 24 VDC  
Internal voltage drop in auto switch is 4 V.

#### 2-wire OR connection

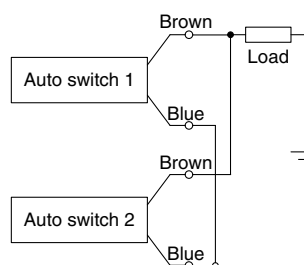

(Solid state)  
When two auto switches are connected in parallel, malfunction may occur because the load voltage will increase when in the OFF state.

(Reed)  
Because there is no current leakage, the load voltage will not increase when turned OFF. However, depending on the number of auto switches in the ON state, the indicator lights may sometimes grow dim or not light up, due to the dispersion and reduction of the current flowing to the auto switches.

$$\begin{aligned} \text{Load voltage at OFF} &= \text{Leakage current} \times 2 \text{ pcs.} \times \\ &\quad \text{Load impedance} \\ &= 1 \text{ mA} \times 2 \text{ pcs.} \times 3 \text{ k}\Omega \\ &= 6 \text{ V} \end{aligned}$$

Example: Load impedance is 3 k $\Omega$ .  
Leakage current from auto switch is 1 mA.





Please contact SMC for detailed specifications, delivery and prices.

## Simple Specials

The following special specifications can be ordered as a simplified Made-to-Order. There is a specification sheet available on paper and CD-ROM. Please contact your SMC sales representatives if necessary.

Symbol	Specifications	C96 (Standard type)		C96Y (Smooth cylinder)	Page
		Double acting			
		Single rod	Double rod	Single rod	
-XA0 to 30	Change of rod end shape	●	●	●	Page 33
-XC14	Change of trunnion bracket mounting position	●	●	●	Page 34

## Made to Order

Symbol	Specifications	C96 (Standard type)		C96Y (Smooth cylinder)	Page
		Double acting			
		Single rod	Double rod	Single rod	
-XB6	Heat resistant cylinder (-10 to 150°C) <sup>Note)</sup>	●	●		Page 35
-XB7	Cold resistant cylinder (-40 to 70°C) <sup>Note)</sup>	●	●		Page 35
-XC4	With heavy duty scraper	●	●		Page 36
-XC7	Tie-rod, tie-rod nut, etc. made of stainless steel	●	●	●	Page 36
-XC10	Dual stroke cylinder/Double rod type	●		●	Page 37
-XC11	Dual stroke cylinder/Single rod type	●			Page 38
-XC22	Fluororubber seal	●	●		Page 39
-XC35	With coil scraper	●	●		Page 39
-XC65	Made of stainless steel (Combination of -XC7 and -XC68)	●	●	●	Page 40
-XC68	Made of stainless steel (with hard chrome plated piston rod)	●	●	●	Page 40
-XC88	Spatter resistant coil scraper, Lube-retainer, grease for welding (Piston rod: Stainless steel 304)	●	●		Page 41
-XC89	Spatter resistant coil scraper, Lube-retainer, grease for welding (Piston rod: S45C)	●	●		Page 41

Note) The products with an auto switch are not compatible.

# Series C96 Simple Specials

These changes are dealt with Simple Specials System.

For details, refer to the Simple Specials System in the WEB catalog.  
<http://www.smcworld.com>

## 1 Change of Rod End Shape

Symbol  
**-XA0 to -XA30**

### Applicable Series

Description	Model	Action	Symbol for change of rod end shape
Standard type	<b>C96S</b>	Double acting, Single rod	XA0 to 30
	<b>C96S-W</b>	Double acting, Double rod	XA0 to 30
Smooth type	<b>C96Y</b>	Double acting, Single rod	XA0 to 30

### ⚠ Precautions

- SMC will make appropriate arrangements if no dimension, tolerance, or finish instructions are given in the diagram.
- Standard dimensions marked with "\*" will be as follows to the rod diameter (D). Enter any special dimension you desire.  
 $D \leq 6 \rightarrow D - 1 \text{ mm}$ ,  $6 < D \leq 25 \rightarrow D - 2 \text{ mm}$ ,  $D > 25 \rightarrow D - 4 \text{ mm}$
- In the case of double rod type and single acting retraction type, enter the dimensions when the rod is retracted.
- Only the single side of a double rod is able to manufacture.

<b>Symbol: A0</b> 	<b>Symbol: A1</b> 	<b>Symbol: A2</b> 	<b>Symbol: A3</b> 	<b>Symbol: A4</b> 
<b>Symbol: A5</b> 	<b>Symbol: A6</b> 	<b>Symbol: A7</b> 	<b>Symbol: A8</b> 	<b>Symbol: A9</b> 
<b>Symbol: A10</b> 	<b>Symbol: A11</b> 	<b>Symbol: A12</b> 	<b>Symbol: A13</b> 	<b>Symbol: A14</b> 
<b>Symbol: A15</b> 	<b>Symbol: A16</b> 	<b>Symbol: A17</b> 	<b>Symbol: A18</b> 	<b>Symbol: A19</b> 
<b>Symbol: A20</b> 	<b>Symbol: A21</b> 	<b>Symbol: A22</b> 	<b>Symbol: A23</b> 	<b>Symbol: A24</b> 
<b>Symbol: A25</b> 	<b>Symbol: A26</b> 	<b>Symbol: A27</b> 	<b>Symbol: A28</b> 	<b>Symbol: A29</b> 
<b>Symbol: A30</b> 				

## 2 Change of Trunnion Bracket Mounting Position

The position for mounting the trunnion pivot bracket on the cylinder can be moved from the standard mounting position to any desired position.

### Applicable Series

Description	Model	Action
Standard type	<b>C96S</b>	Double acting, Single rod
	<b>C96S-W</b>	Double acting, Double rod
Smooth type	<b>C96Y</b>	Double acting, Single rod

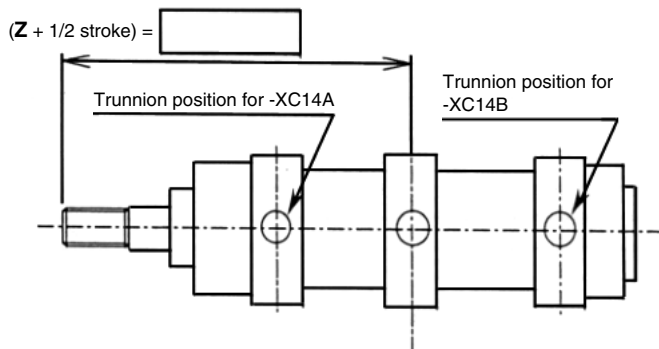

### ⚠ Precautions

1. Specify "Z + 1/2 stroke" in the case the trunnion bracket position is not -XC14A, B or trunnion is not a center trunnion.
2. SMC will make appropriate arrangements if no dimension, tolerance, or finish instructions are given in the diagram.
3. The possible range of trunnion bracket mounting position is indicated in the table below.
4. Some trunnion mounting positions do not allow auto switch mounting. Please consult with SMC for more information.

### Series C96

[mm]

Bore size	Symbol	Trunnion bracket position			
		For -XC14		Reference: Standard (Center trunnion)	Minimum stroke
		Minimum	Maximum		
<b>32</b>		86	104 + Stroke	95 + 0.5 stroke	0
<b>40</b>		98	115 + Stroke	106.5 + 0.5 stroke	
<b>50</b>		112.5	131.5 + Stroke	122 + 0.5 stroke	
<b>63</b>		122	137 + Stroke	129.5 + 0.5 stroke	
<b>80</b>		142	158 + Stroke	150 + 0.5 stroke	
<b>100</b>		154.5	165.5 + Stroke	160 + 0.5 stroke	5

# Series C96

## Made to Order

Please contact SMC for detailed dimensions, specifications and lead times.



### 1 Heat Resistant Cylinder (−10 to 150°C)

Symbol

**-XB6**

Air cylinder which changed the seal material and grease, so that it could be used even at higher temperature up to 150°C.

#### Applicable Series

Description	Model	Action
Standard type	<b>C96S</b>	Double acting, Single rod
	<b>C96S-W</b>	Double acting, Double rod

#### How to Order

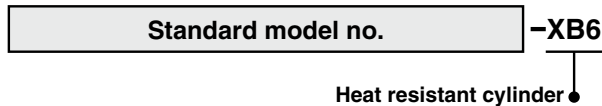

#### Specifications

Ambient temperature range	−10 to 150°C
Seal material	Fluororubber
Grease	Heat resistant grease
Specifications other than above and external dimensions	Same as standard type

- Note 1) Operate without lubrication from a pneumatic system lubricator.  
 Note 2) Please contact SMC for details on the maintenance intervals for this cylinder, which differ from those of the standard cylinder.  
 Note 3) In principle, it is impossible to make built-in magnet type and the one with auto switch.  
 But, as for the one with auto switch, and the heat resistant cylinder with heat resistant auto switch, since it will be differed depending on the series, please contact SMC.  
 Note 4) Piston speed is ranged from 50 to 500 mm/s.

#### Warning

#### Precautions

Be aware that smoking cigarettes etc. after your hands have come into contact with the grease used in this cylinder can create a gas that is hazardous to humans.

### 2 Cold Resistant Cylinder (−40 to 70°C)

Symbol

**-XB7**

Air cylinder which changed the seal material and grease, so that it could be used even at lower temperature down to −40°C.

#### Applicable Series

Description	Model	Action	Note
Standard type	<b>C96S</b>	Double acting, Single rod	Except with auto switch. Mounting bracket: Basic type only. Minimum operating pressure 0.2 MPa
	<b>C96S-W</b>	Double acting, Double rod	

#### How to Order

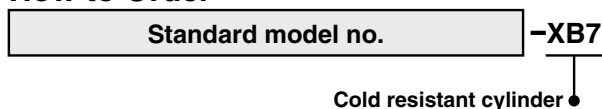

#### Specifications

Ambient temperature range	−40 to 70°C
Seal material	Low nitrile rubber
Grease	Cold resistant grease
Auto switch	Not mountable
Dimensions	Same as standard type
Specifications other than above	Same as standard type

- Note 1) Operate without lubrication from a pneumatic system lubricator.  
 Note 2) Use dry air which is suitable for heatless air dryer etc. not to cause the moisture to be frozen.  
 Note 3) Please contact SMC for details on the maintenance intervals for this cylinder, which differ from those of the standard cylinder.  
 Note 4) Mounting auto switch is impossible.

#### Warning

#### Precautions

Be aware that smoking cigarettes etc. after your hands have come into contact with the grease used in this cylinder can create a gas that is hazardous to humans.

Symbol  
**-XC4**

### 3 With Heavy Duty Scraper

It is suitable for using cylinders under the environment, where there are much dusts in a surrounding area by using a heavy duty scraper on the wiper ring, or using cylinders under earth and sand exposed to the die-casted equipment, construction machinery, or industrial vehicles.

#### Applicable Series

Description	Model	Action
Standard type	<b>C96S</b>	Double acting, Single rod
	<b>C96S-W</b>	Double acting, Double rod

#### How to Order

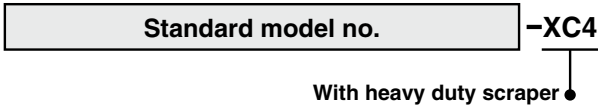

**Specifications: Same as standard type**

**Dimensions: Same as standard type**

#### ⚠ Caution

**Do not replace heavy duty scrapers.**

Since heavy duty scrapers are press-fit, do not replace the cover only, but rather the entire rod cover assembly.

Symbol  
**-XC7**

### 4 Tie-rod, Tie-rod Nut, etc. Made of Stainless Steel

When using in locations where the rust generation or corrosion likelihood exists, the standard parts material have been partly changed to the stainless steel.

#### Applicable Series

Description	Model	Action
Standard type	<b>C96S</b>	Double acting, Single rod
	<b>C96S-W</b>	Double acting, Double rod
Smooth type	<b>C96Y</b>	Double acting, Single rod

#### How to Order

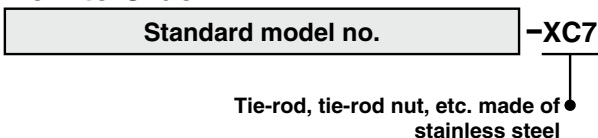

#### Specifications

<b>Parts changed to stainless steel</b>	Tie-rod, Tie-rod nut, Mounting bracket nut, Spring washer, Lock nut
<b>Specifications other than above</b>	Same as standard type for each series
<b>Dimensions</b>	Same as standard type for each series

# Series C96

Symbol

## 5 Dual Stroke Cylinder/Double Rod Type

**-XC10**

Two cylinders are constructed as one cylinder in a back-to-back configuration allowing the cylinder stroke to be controlled in three steps.

### Applicable Series

Description	Model	Action	Note
Standard type	<b>C96S</b>	Double acting, Single rod	Except clevis and trunnion types
Smooth type	<b>C96Y</b>	Double acting, Single rod	Except clevis and trunnion types

### How to Order

C96S **Mounting style** **Bore size** - **Stroke A** + **Stroke B** C - XC10  
 C96Y

Dual stroke cylinder

### Specifications

Maximum manufacturable stroke [mm]
1000

### Function

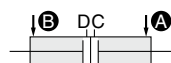

When air pressure is supplied to ports **A** and **B**, both strokes A and B retract.

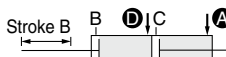

When air pressure is supplied to ports **A** and **D**, B out strokes.



When air pressure is supplied to ports **B** and **C**, A out strokes.



When air pressure is supplied to ports **C** and **D**, both strokes A and B out strokes.

### Dimensions (Dimensions other than below are the same as standard type.)

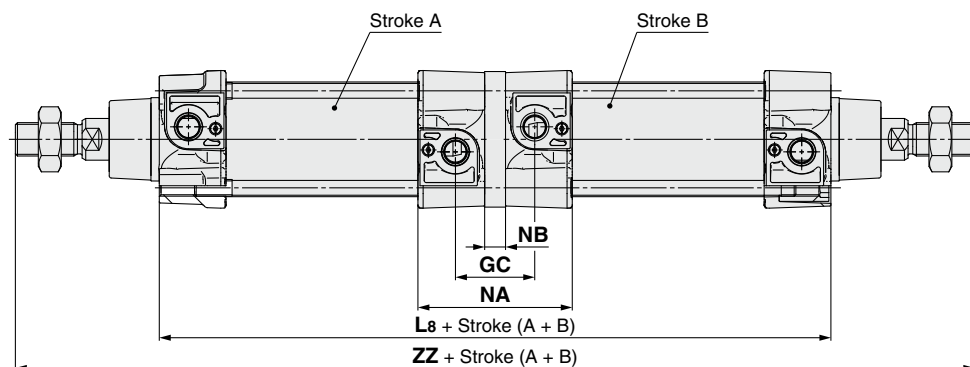

Bore size [mm]	L8	ZZ	NA	NB	GC
ø32	198	294	67.8	10	36
ø40	220	328	75.2	10	38
ø50	222	360	74	10	38
ø63	252	390	87.2	10	42
ø80	270	442	90.8	14	46
ø100	290	472	99.8	14	50

Symbol  
**-XC11**

## 6 Dual Stroke Cylinder/Single Rod Type

Two cylinders can be integrated by connecting them in line, and the cylinder stroke can be controlled in two stages in both directions.

### Applicable Series

Description	Model	Action	Note
Standard type	<b>C96S</b>	Double acting, Single rod	Except trunnion type

### How to Order

Specifications: Same as standard type

**C96S** Mounting style Bore size - Stroke A + Stroke B-A **C - XC11**  
Dual stroke cylinder/Single rod type

### Function

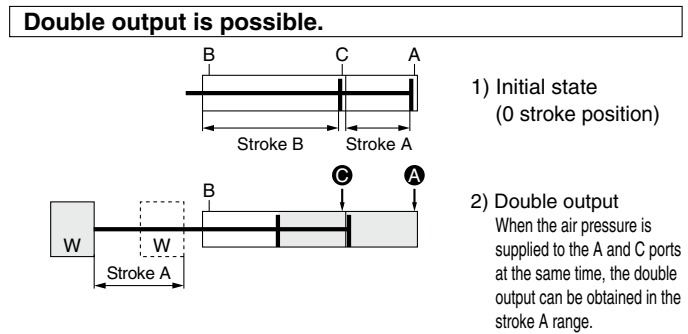
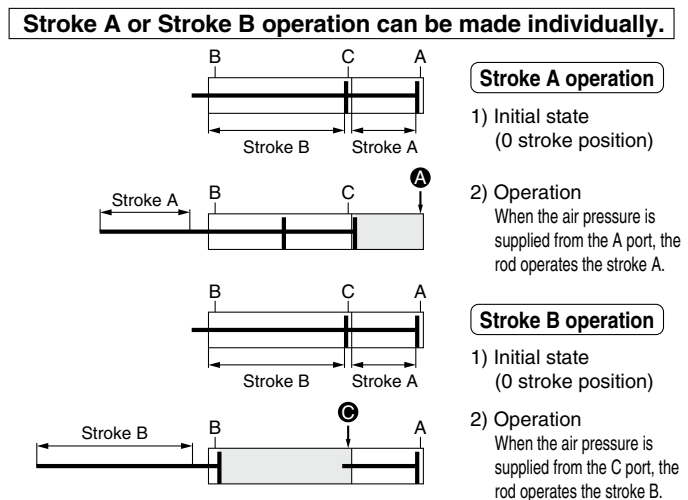
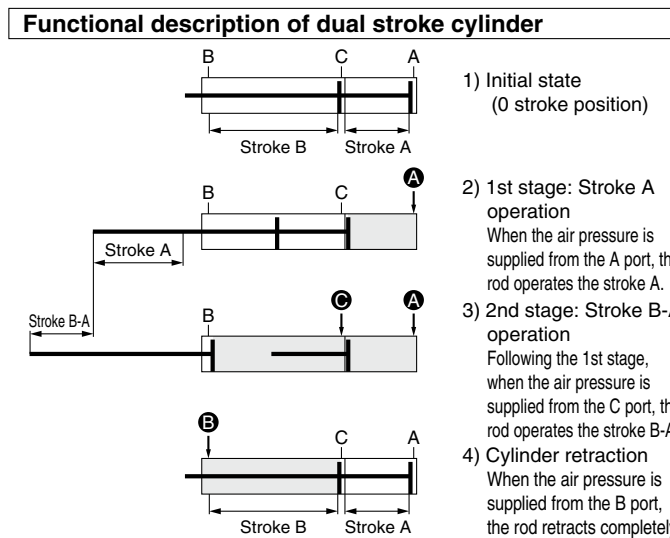

### Precautions

#### ⚠ Caution

1. Do not supply air until the cylinder is fixed with the attached bolt.
2. If air is supplied without securing the cylinder, the cylinder could lurch, posing the risk of bodily injury or damage to the peripheral equipment.

### Dimensions (Dimensions other than below are the same as standard type.)

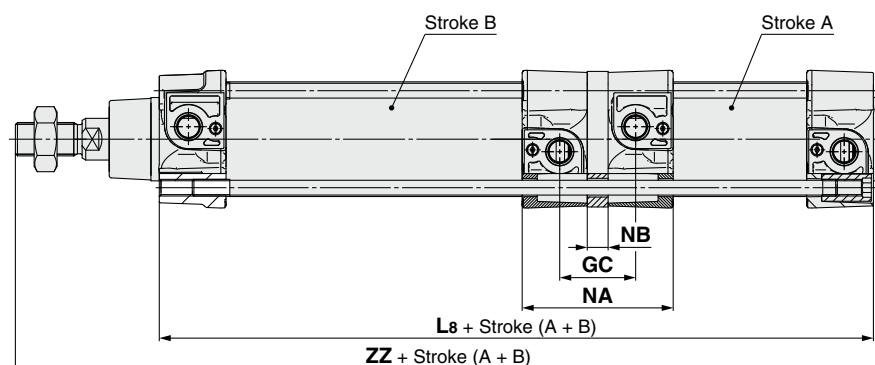

Bore size [mm]	L8	ZZ	NA	NB	GC
ø32	199	251	67.2	10	35.4
ø40	221	279	74.6	10	37.4
ø50	223	296	73.4	10	37.4
ø63	253	326	86.6	10	41.4
ø80	271	361	90.2	14	45.4
ø100	291	386	99.2	14	49.4

## 7 Fluororubber Seal

### Applicable Series

Description	Model	Action
Standard type	<b>C96S</b>	Double acting, Single rod
	<b>C96S-W</b>	Double acting, Double rod

### How to Order

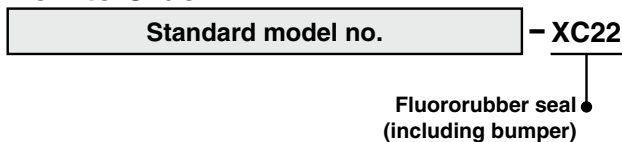

### Specifications

Seal material	Fluororubber
Ambient temperature range	With auto switch: -10°C to 60°C (No freezing) <sup>Note 1)</sup> Without auto switch: -10°C to 70°C (No freezing)
Specifications other than above and external dimensions	Same as standard type

Note 1) Please contact SMC, as the type of chemical and the operating temperature may not allow the use of this product.

Note 2) Cylinders with auto switches can also be produced; however, auto switch related parts (auto switch units, mounting brackets, built-in magnets) are the same as standard products. Before using these, please contact SMC regarding their suitability for the operating environment.

## 8 With Coil Scraper

It gets rid of frost, ice, weld spatter, cutting chips adhered to the piston rod, and protects the seals etc.

### Applicable Series

Description	Model	Action
Standard type	<b>C96S</b>	Double acting, Single rod
	<b>C96S-W</b>	Double acting, Double rod

### How to Order

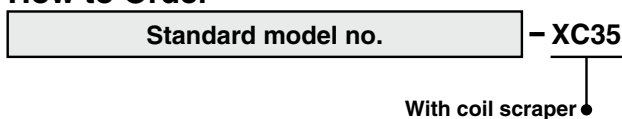

**Specifications: Same as standard type**

**Dimensions: Same as standard type**



Symbol  
**-XC65**

**9 Made of Stainless Steel (Combination of -XC7 and -XC68)**

Suitable for the cases it is likely to generate rust by being immersed in the water and corrosion.

**Applicable Series**

Description	Model	Action
Standard type	<b>C96S</b>	Double acting, Single rod
	<b>C96S-W</b>	Double acting, Double rod
Smooth type	<b>C96Y</b>	Double acting, Single rod

Note) There is a maximum stroke limit for C96 cylinder.

**Maximum Stroke** [mm]

Double acting, Single rod	Double acting, Double rod
ø32: 1000 ø40 to ø100: 1700	1000 (Same as standard type)

**Specifications**

<b>Parts changed to stainless steel</b>	Piston rod, Rod end nut, Tie-rod, Tie-rod nut, Mounting bracket nut, Spring washer, Lock nut
<b>Other specifications and external dimensions</b>	Same as standard type

**How to Order**

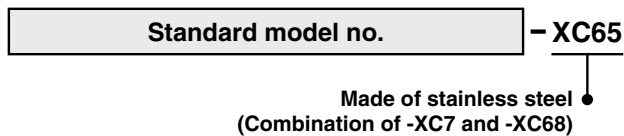

Symbol  
**-XC68**

**10 Made of Stainless Steel (With Hard Chrome Plated Piston Rod)**

Suitable for the cases it is likely to generate rust by being immersed in the water and corrosion.

**Applicable Series**

Description	Model	Action
Standard type	<b>C96S</b>	Double acting, Single rod
	<b>C96S-W</b>	Double acting, Double rod
Smooth type	<b>C96Y</b>	Double acting, Single rod

Note) There is a maximum stroke limit.

**Maximum Stroke** [mm]

Double acting, Single rod	Double acting, Double rod
ø32: 1000 ø40 to ø100: 1700	1000 (Same as standard type)

**Specifications**

<b>Parts changed to stainless steel</b>	Piston rod, Rod end nut
<b>Other specifications and external dimensions</b>	Same as standard type

**How to Order**

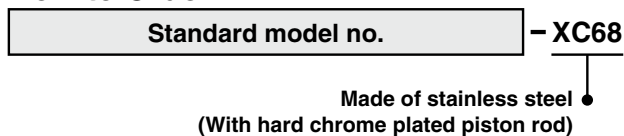

# Series C96

## 11 Spatter Resistant Coil Scraper, Lube-retainer, Grease for Welding (Piston rod: Stainless steel 304)

Symbol  
**-XC88**

Reduces spatter adhesion and improves durability by the use of the coil scraper, Lube-retainer and grease for welding.

### Applicable Series

Description	Model	Action
Standard type	<b>C96S</b>	Double acting, Single rod
	<b>C96S-W</b>	Double acting, Double rod

### How to Order

Standard model no. **- XC88**

● Spatter resistant coil scraper, Lube-retainer, grease for welding (Piston rod: Stainless steel 304)

### Specifications

<b>Piston rod</b>	Stainless steel 304 (With hard chrome plated)
<b>Scraper</b>	With coil scraper, With Lube-retainer
<b>Grease</b>	Grease for welding
<b>Other specifications and external dimensions</b>	Same as standard type

## 12 Spatter Resistant Coil Scraper, Lube-retainer, Grease for Welding (Piston rod: S45C)

Symbol  
**-XC89**

Reduces spatter adhesion and improves durability by the use of the coil scraper, Lube-retainer and grease for welding.

### Applicable Series

Description	Model	Action
Standard type	<b>C96S</b>	Double acting, Single rod
	<b>C96S-W</b>	Double acting, Double rod

### How to Order

Standard model no. **- XC89**

● Spatter resistant coil scraper, Lube-retainer, grease for welding (Piston rod: S45C)

### Specifications

<b>Piston rod</b>	S45C (With hard chrome plated)
<b>Scraper</b>	With coil scraper, With Lube-retainer
<b>Grease</b>	Grease for welding
<b>Other specifications and external dimensions</b>	Same as standard type



## Series C96

# Specific Product Precautions

Be sure to read this before handling. Refer to the back cover for Safety Instructions. For Actuator and Auto Switch Precautions, refer to “Handling Precautions for SMC Products” and the Operation Manual on SMC website, <http://www.smcworld.com>

### Adjustment

## Warning

### 1. Do not open the cushion valve more than the allowable number of rotations (following table).

Although the cushion valve is caulked as a retaining mechanism, do not open the cushion valve more than the allowable number of rotations. If air is supplied and operation started without confirming the above condition, the cushion valve may be ejected from the cover.

The allowable number of rotations refers to the number of rotations until the restrictor of the cushion valve is completely opened from the completely closed state.

### 2. Keep the screwing torque and the unscrewing torque of the cushion valve to the allowable torque or below (following table).

If a screwing torque or unscrewing torque beyond the allowable torque is applied, the valve will be damaged when the valve is closed completely or exceeds the retaining mechanism when the valve is opened completely, which will dislocate the engagement of the screw and eject the valve.

Bore size [mm]	Cushion valve width across flats	Hexagon wrench	Allowable number of rotations	Allowable torque [N·m]
<b>32, 40</b>	2	JIS 4648 Hexagon wrench key 2	4	0.02
<b>50, 63</b>	2	JIS 4648 Hexagon wrench key 2	4.5	0.02
<b>80, 100</b>	3	JIS 4648 Hexagon wrench key 3	5.5	0.06

### 3. Be certain to activate the air cushion at the stroke end.

When the air cushion is inactivated, if the allowable kinetic energy exceeds the value on page 5, the piston rod assembly or the tie-rod may be damaged. Set the air cushion to valid when operating the cylinder.

## Caution

### 1. When replacing brackets, use the hexagon wrenches shown below.

Bore size [mm]	Width across flats	Tightening torque [N·m]
<b>32, 40</b>	4	4.8
<b>50, 63</b>	5	10.4
<b>80, 100</b>	6	18.2

## Safety Instructions

These safety instructions are intended to prevent hazardous situations and/or equipment damage. These instructions indicate the level of potential hazard with the labels of “**Caution**,” “**Warning**” or “**Danger**.” They are all important notes for safety and must be followed in addition to International Standards (ISO/IEC)\*1), and other safety regulations.

 **Caution:** **Caution** indicates a hazard with a low level of risk which, if not avoided, could result in minor or moderate injury.

 **Warning:** **Warning** indicates a hazard with a medium level of risk which, if not avoided, could result in death or serious injury.

 **Danger :** **Danger** indicates a hazard with a high level of risk which, if not avoided, will result in death or serious injury.

\*1) ISO 4414: Pneumatic fluid power – General rules relating to systems.  
ISO 4413: Hydraulic fluid power – General rules relating to systems.  
IEC 60204-1: Safety of machinery – Electrical equipment of machines.  
(Part 1: General requirements)  
ISO 10218-1: Manipulating industrial robots – Safety.  
etc.

### Warning

#### 1. The compatibility of the product is the responsibility of the person who designs the equipment or decides its specifications.

Since the product specified here is used under various operating conditions, its compatibility with specific equipment must be decided by the person who designs the equipment or decides its specifications based on necessary analysis and test results. The expected performance and safety assurance of the equipment will be the responsibility of the person who has determined its compatibility with the product. This person should also continuously review all specifications of the product referring to its latest catalog information, with a view to giving due consideration to any possibility of equipment failure when configuring the equipment.

#### 2. Only personnel with appropriate training should operate machinery and equipment.

The product specified here may become unsafe if handled incorrectly. The assembly, operation and maintenance of machines or equipment including our products must be performed by an operator who is appropriately trained and experienced.

#### 3. Do not service or attempt to remove product and machinery/equipment until safety is confirmed.

1. The inspection and maintenance of machinery/equipment should only be performed after measures to prevent falling or runaway of the driven objects have been confirmed.
2. When the product is to be removed, confirm that the safety measures as mentioned above are implemented and the power from any appropriate source is cut, and read and understand the specific product precautions of all relevant products carefully.
3. Before machinery/equipment is restarted, take measures to prevent unexpected operation and malfunction.

#### 4. Contact SMC beforehand and take special consideration of safety measures if the product is to be used in any of the following conditions.

1. Conditions and environments outside of the given specifications, or use outdoors or in a place exposed to direct sunlight.
2. Installation on equipment in conjunction with atomic energy, railways, air navigation, space, shipping, vehicles, military, medical treatment, combustion and recreation, or equipment in contact with food and beverages, emergency stop circuits, clutch and brake circuits in press applications, safety equipment or other applications unsuitable for the standard specifications described in the product catalog.
3. An application which could have negative effects on people, property, or animals requiring special safety analysis.
4. Use in an interlock circuit, which requires the provision of double interlock for possible failure by using a mechanical protective function, and periodical checks to confirm proper operation.

### Caution

#### 1. The product is provided for use in manufacturing industries.

The product herein described is basically provided for peaceful use in manufacturing industries.  
If considering using the product in other industries, consult SMC beforehand and exchange specifications or a contract if necessary.  
If anything is unclear, contact your nearest sales branch.

### Limited warranty and Disclaimer/ Compliance Requirements

The product used is subject to the following “Limited warranty and Disclaimer” and “Compliance Requirements”.

Read and accept them before using the product.

#### Limited warranty and Disclaimer

1. The warranty period of the product is 1 year in service or 1.5 years after the product is delivered, whichever is first.\*2)  
Also, the product may have specified durability, running distance or replacement parts. Please consult your nearest sales branch.
2. For any failure or damage reported within the warranty period which is clearly our responsibility, a replacement product or necessary parts will be provided.  
This limited warranty applies only to our product independently, and not to any other damage incurred due to the failure of the product.
3. Prior to using SMC products, please read and understand the warranty terms and disclaimers noted in the specified catalog for the particular products.

##### \*2) Vacuum pads are excluded from this 1 year warranty.

A vacuum pad is a consumable part, so it is warranted for a year after it is delivered.  
Also, even within the warranty period, the wear of a product due to the use of the vacuum pad or failure due to the deterioration of rubber material are not covered by the limited warranty.

#### Compliance Requirements

1. The use of SMC products with production equipment for the manufacture of weapons of mass destruction (WMD) or any other weapon is strictly prohibited.
2. The exports of SMC products or technology from one country to another are governed by the relevant security laws and regulations of the countries involved in the transaction. Prior to the shipment of a SMC product to another country, assure that all local rules governing that export are known and followed.

### Caution

#### SMC products are not intended for use as instruments for legal metrology.

Measurement instruments that SMC manufactures or sells have not been qualified by type approval tests relevant to the metrology (measurement) laws of each country. Therefore, SMC products cannot be used for business or certification ordained by the metrology (measurement) laws of each country.

#### Revision history

- Edition B**
- \* Standard type, double rod C96-W series added.
  - \* Non-rotating rod type, single rod C96K series, double rod C96K-W series added.
  - \* Smooth cylinder C96Y series added.
  - \* Made to Order: Heat resistant cylinder (-XB6), With heavy duty scraper (-XC4), With coil scraper (-XC35), etc. added.
  - \* Number of pages increased from 24 to 44.

TV

## Safety Instructions

Be sure to read “Handling Precautions for SMC Products” (M-E03-3) before using.