

Electric Actuator

LEL Series

Guide Rod Slider

Step Motor (Servo/24 VDC)



Low-profile/Flat Height 48 mm

Profile reduced by side mounting of motor

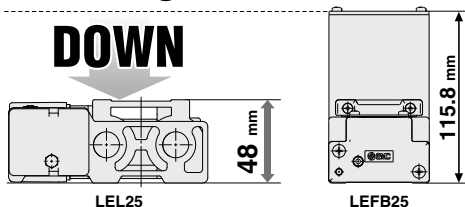

Max. stroke: 1000 mm
Transfer speed: 1000 mm/s

No interference with motor, even with large workpieces!

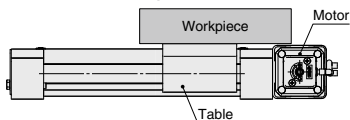

Belt drive
With belt cover

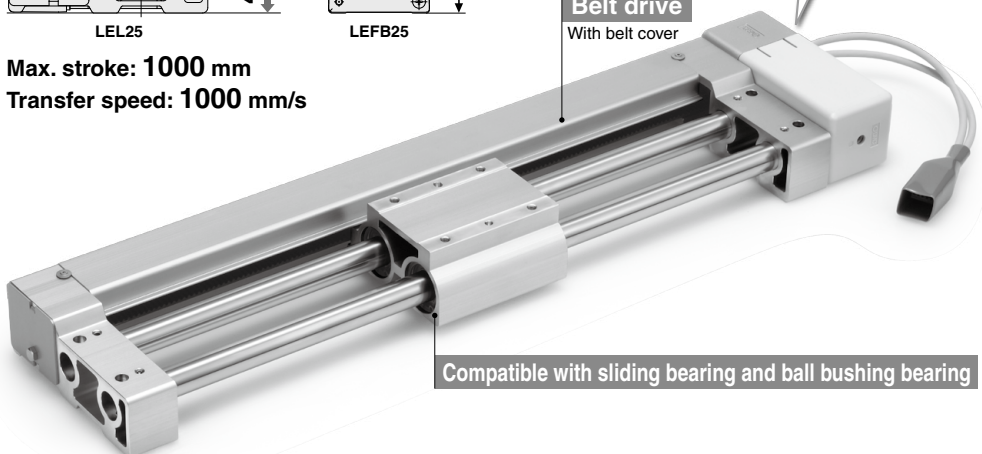

Compatible with sliding bearing and ball bushing bearing

Model	Size	Bearing	Stroke [mm]	Work load (Horizontal) [kg]	Speed [mm/s]	Positioning repeatability [mm]	Page
LEL25M	25	Sliding bearing	Up to 1000	3	Up to 500	±0.08	▶Page 152
LEL25L		Ball bushing bearing	Up to 1000	5	Up to 1000	±0.08	

Step Motor (Servo/24 VDC) Controller

▶Page 547

▶Step data input type
LECP6 Series

- 64 points positioning
- Input using controller setting kit or teaching box



▶CC-Link direct input type
LECPMJ Series*

* Not applicable to CE.



▶EtherCAT®/
EtherNet/IP™/
PROFINET/
DeviceNet™/
IO-Link
direct input type
JXCE1/91/P1/D1/L1 Series



▶Programless type
LECP1 Series

- 14 points positioning
- Control panel setting



LEL Series

Step Motor (Servo/24 VDC) Type

Guide Rod Slider Size: 25

Simple construction. Guide type can be selected.

Max. stroke: **1000 mm**

Transfer speed: **1000 mm/s**

Guide type

- **Sliding bearing**

Work load: 3 kg (Horizontal)

Reduced noise (60 dB or less) ^{Note)}

- **Ball bushing bearing**

Work load: 5 kg (Horizontal)

Transfer speed: 1000 mm/s

Note) When the maximum speed is 500 mm/s
(Measured by SMC)

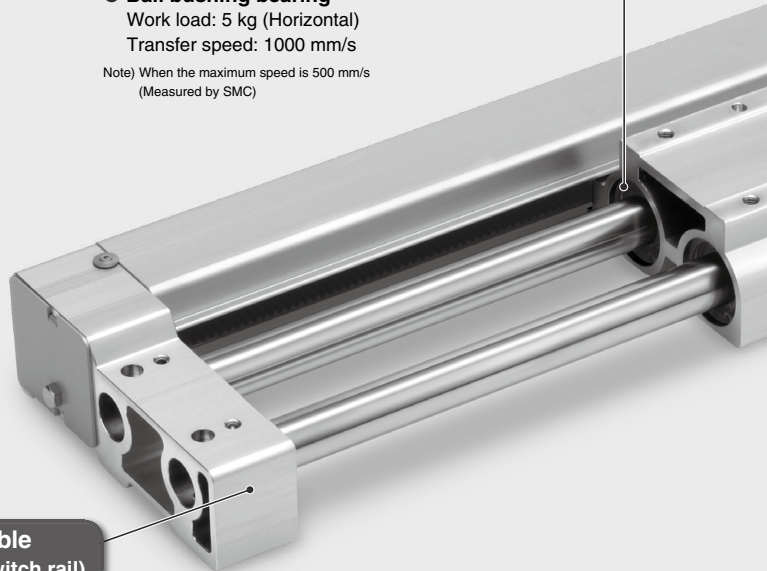

Auto switch mountable (Option: With magnet/switch rail)

For checking the limit and intermediate signal
Applicable to the D-M9□ and D-M9□W (2-color indicator)

* The auto switches should be ordered separately. Refer to pages 161 and 162 for details.

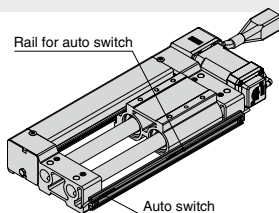

2-color indicator solid state auto switch

Appropriate setting of the mounting position
can be performed without mistakes.

A **green** light
lights up at the
optimum operating
range.

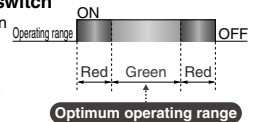

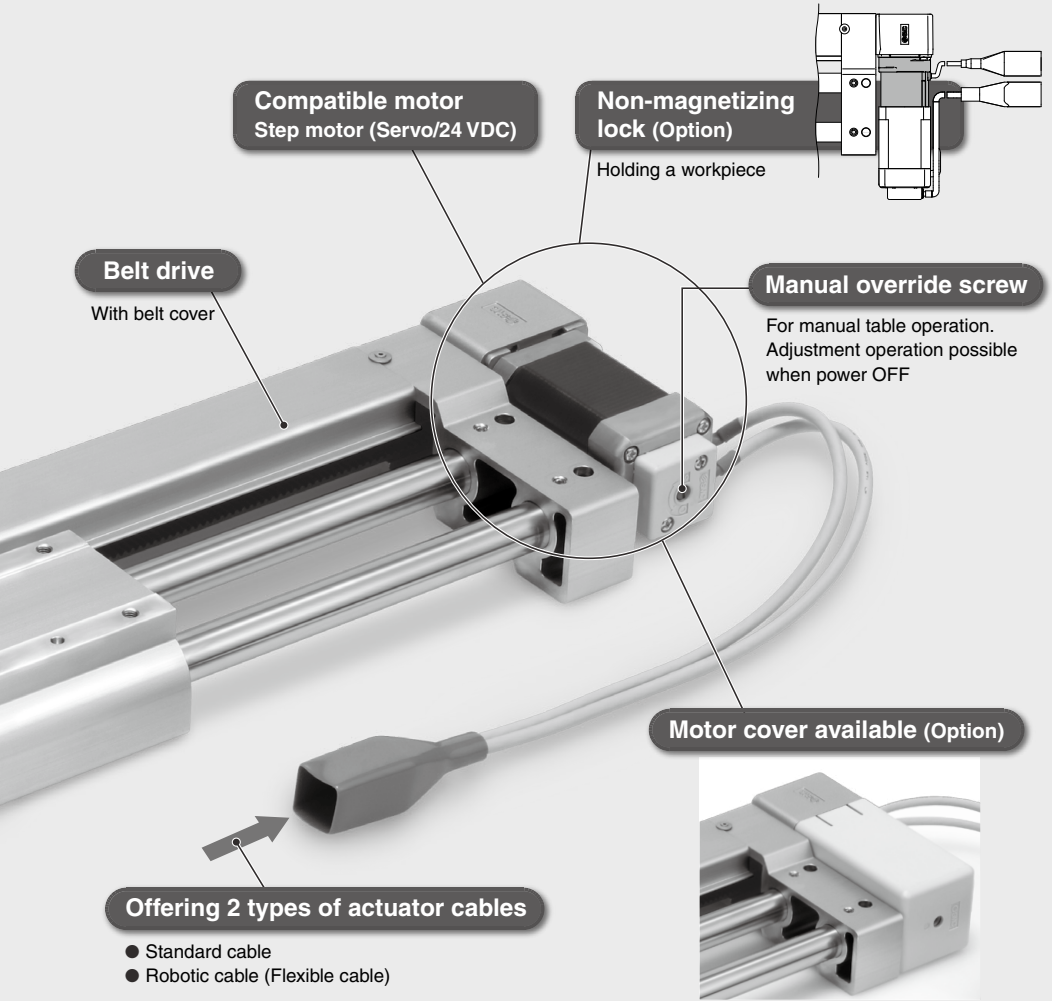

Application Examples

Load and unload transfer of workpieces

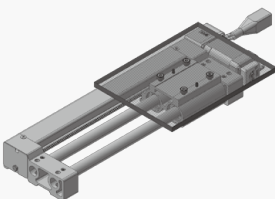

Pick and place

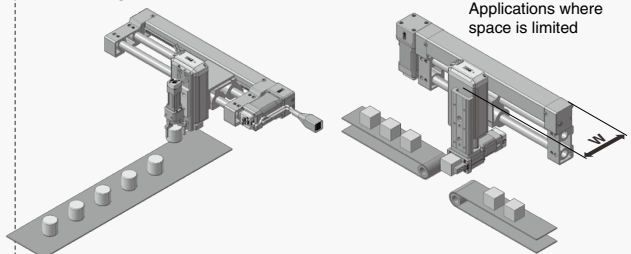

Step Motor (Servo/24 VDC)

Electric Actuator/Guide Rod Slider *LEL Series*



Model Selection	Page 152
How to Order	Pages 156, 157-1
Specifications	Page 158
Construction	Page 159
Dimensions	Page 160
Auto Switch	Page 161
Specific Product Precautions	Page 163

Step Motor (Servo/24 VDC) Controller



Step Data Input Type/ <i>LECP6 Series</i>	Page 560
Controller Setting Kit/ <i>LEC-W2</i>	Page 569
Teaching Box/ <i>LEC-T1</i>	Page 570
CC-Link Direct Input Type/ <i>LECPMJ Series</i>	Page 600
Controller Setting Kit/ <i>LEC-W2</i>	Page 603-2
Teaching Box/ <i>LEC-T1</i>	Page 603-3
EtherCAT®/EtherNet/IP™/PROFINET/DeviceNet™/IO-Link Direct Input Type/ <i>JXCE1/91/P1/D1/L1 Series</i>	Page 603-5
Controller Setting Kit/ <i>LEC-W2</i>	Page 603-10
Teaching Box/ <i>LEC-T1</i>	Page 605
Gateway Unit/ <i>LEC-G Series</i>	Page 572
Programless Controller/ <i>LECP1 Series</i>	Page 576

Guide Rod Slider

LEL Series

Step Motor (Servo/24 VDC)



Model Selection



LEL Series Pages 156, 157-1

Selection Procedure

- Step 1** Check the work load-speed. → **Step 2** Check the cycle time. → **Step 3** Check the allowable moment.

Selection Example

Operating conditions

- Workpiece mass: 4 [kg]
- Speed: 300 [mm/s]
- Acceleration/Deceleration: 3000 [mm/s²]
- Stroke: 500 [mm]
- Mounting position: Horizontal upward
- Workpiece mounting condition:

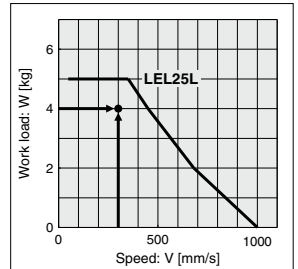
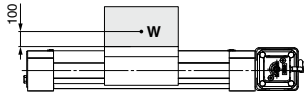

<Speed-Work load graph>
(LEL25L/Step motor)

Step 1 Check the work load-speed. <Speed-Work load graph> (Page 155)
Select the target model based on the workpiece mass and speed with reference to the <Speed-Work load graph>.

Selection example) The LEL25LT-500 is temporarily selected based on the graph shown on the right side.

Step 2 Check the cycle time.

Calculate the cycle time using the following calculation method.

Cycle time:

T can be found from the following equation.

$$T = T1 + T2 + T3 + T4 \text{ [s]}$$

- T1: Acceleration time and T3: Deceleration time can be obtained by the following equation.

$$T1 = V/a1 \text{ [s]} \quad T3 = V/a2 \text{ [s]}$$

- T2: Constant speed time can be found from the following equation.

$$T2 = \frac{L - 0.5 \cdot V \cdot (T1 + T3)}{V} \text{ [s]}$$

- T4: Settling time varies depending on the conditions such as motor types, load and in position of the step data. Therefore, please calculate the settling time with reference to the following value.

$$T4 = 0.3 \text{ [s]}$$

Calculation example)

T1 to T4 can be calculated as follows.

$$T1 = V/a1 = 300/3000 = 0.1 \text{ [s]}$$

$$T3 = V/a2 = 300/3000 = 0.1 \text{ [s]}$$

$$T2 = \frac{L - 0.5 \cdot V \cdot (T1 + T3)}{V} \\ = \frac{500 - 0.5 \cdot 300 \cdot (0.1 + 0.1)}{300} \\ = 1.57 \text{ [s]}$$

$$T4 = 0.3 \text{ [s]}$$

Therefore, the cycle time can be obtained as follows.

$$T = T1 + T2 + T3 + T4 \\ = 0.1 + 1.57 + 0.1 + 0.3 \\ = 2.07 \text{ [s]}$$

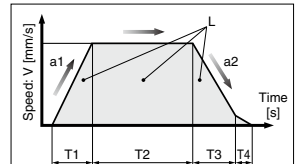

- L : Stroke [mm]
- ... (Operating condition)
- V : Speed [mm/s]
- ... (Operating condition)
- a1 : Acceleration [mm/s²]
- ... (Operating condition)
- a2 : Deceleration [mm/s²]
- ... (Operating condition)

- T1: Acceleration time [s]
Time until reaching the set speed
- T2: Constant speed time [s]
Time while the actuator is operating at a constant speed
- T3: Deceleration time [s]
Time from the beginning of the constant speed operation to stop
- T4: Settling time [s]
Time until positioning is completed

Step 3 Check the guide moment.

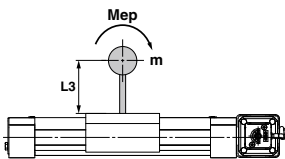

Based on the above calculation result, the LEL25LT-500 is selected.

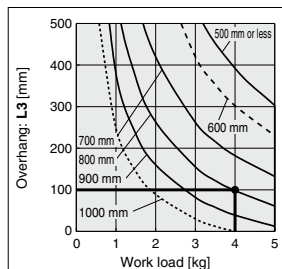

Dynamic Allowable Moment

* This graph shows the amount of allowable overhang (guide unit) when the center of gravity of the workpiece overhangs in one direction. When selecting the overhang, refer to "Calculation of Guide Load Factor" or the Electric Actuator Selection Software for confirmation, <http://www.smcworld.com>

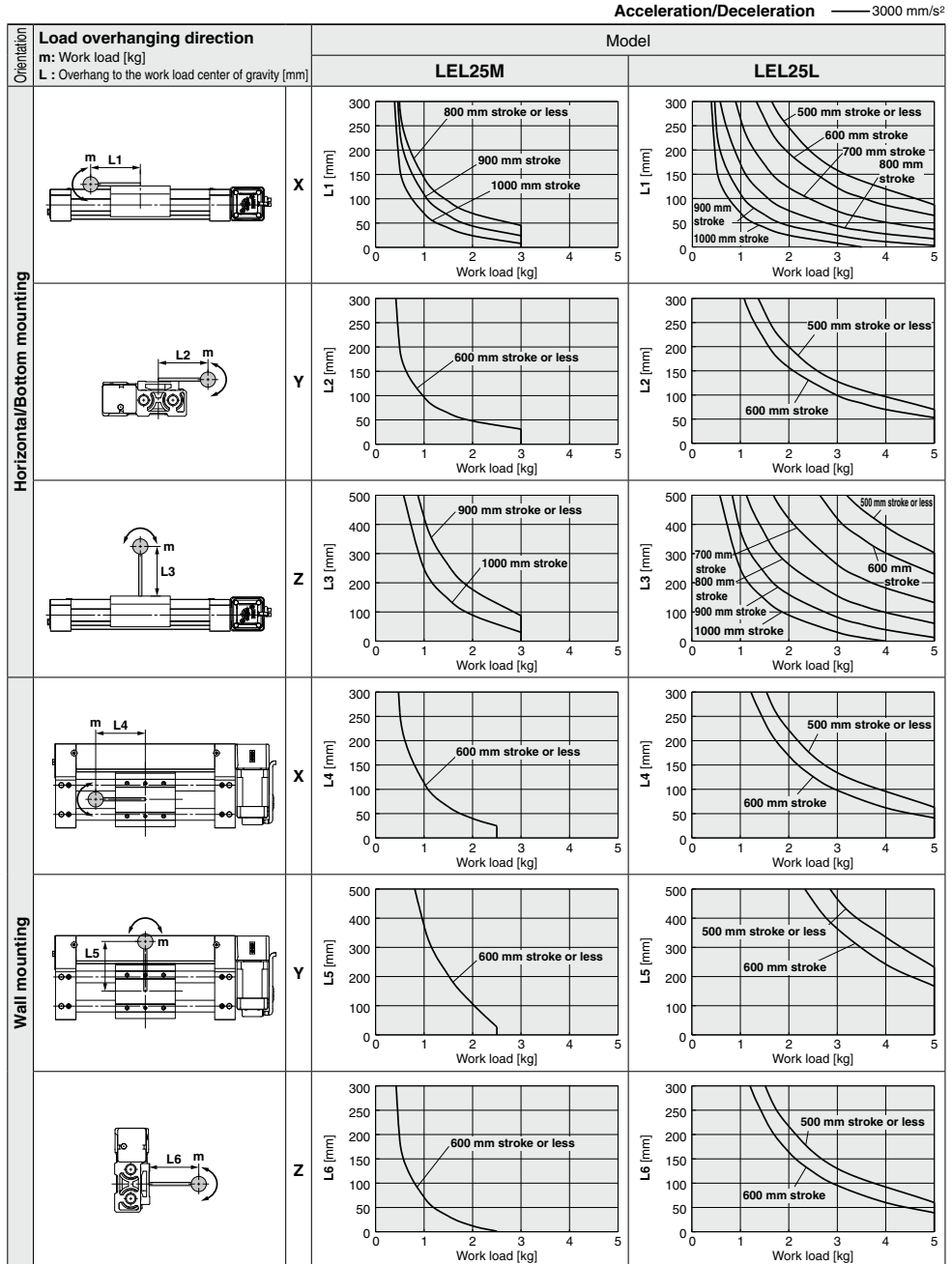

Calculation of Guide Load Factor

1. Decide operating conditions.

Model: LEL

Size: 25

Mounting orientation: Horizontal/Bottom/Wall

Acceleration [mm/s²]: a

Work load [kg]: m

Work load center position [mm]: Xc/Yc/Zc

2. Select the target graph with reference to the model, size and mounting orientation.

3. Based on the acceleration and work load, obtain the overhang [mm]: Lx/Ly/Lz from the graph.

4. Calculate the load factor for each direction.

$$\alpha_x = Xc/Lx, \alpha_y = Yc/Ly, \alpha_z = Zc/Lz$$

5. Confirm the total of α_x , α_y and α_z is 1 or less.

$$\alpha_x + \alpha_y + \alpha_z \leq 1$$

When 1 is exceeded, please consider a reduction of acceleration and work load, or a change of the work load center position and series.

Mounting orientation

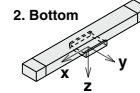
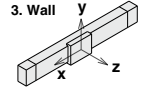
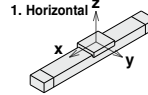

Example

1. Operating conditions

Model: LEL

Size: 25L

Stroke: 500

Mounting orientation: Horizontal

Acceleration [mm/s²]: 3000

Work load [kg]: 4

Work load center position [mm]: Xc = 30, Yc = 20, Zc = 100

2. Select three graphs from the top of the right side on page 153.

3. Lx = 120 mm, Ly = 65 mm, Lz = 390 mm

4. The load factor for each direction can be obtained as follows.

$$\alpha_x = 30/120 = 0.25$$

$$\alpha_y = 20/65 = 0.31$$

$$\alpha_z = 100/390 = 0.26$$

5. $\alpha_x + \alpha_y + \alpha_z = 0.82 \leq 1$

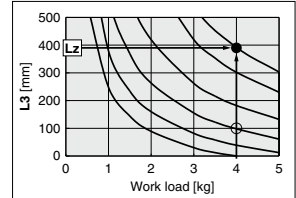
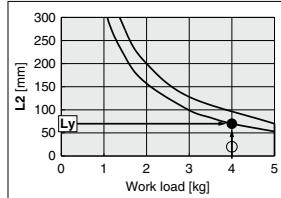
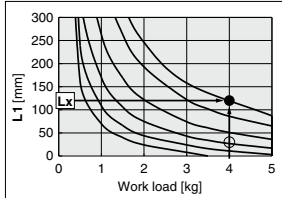

Speed-Work Load Graph (Guide)

LEL25M

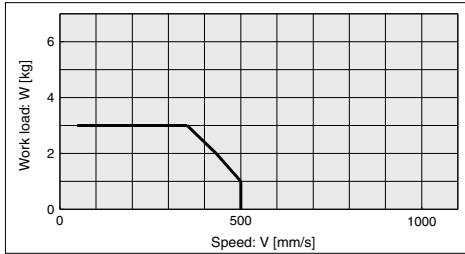

LEL25L

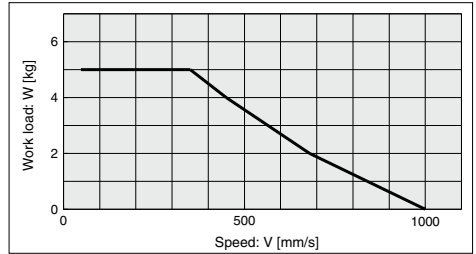
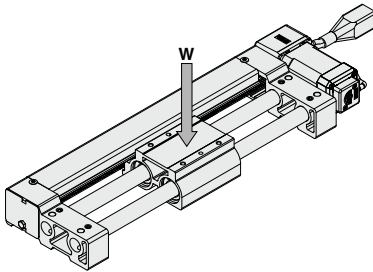
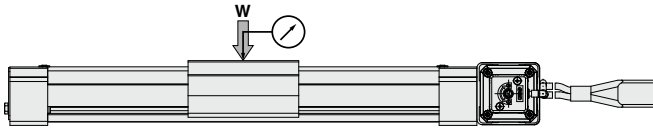

Table Displacement (Reference Value)

* Amount of displacement of the table when the load center of gravity is located at the table center in the middle of the stroke.



Load center of gravity located at the center of the table

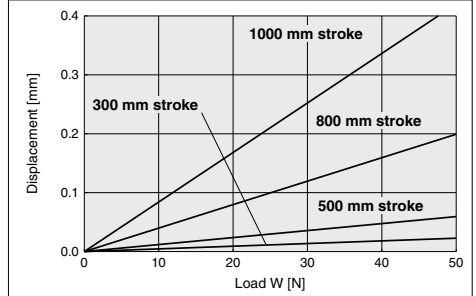
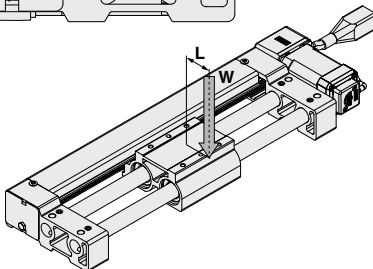
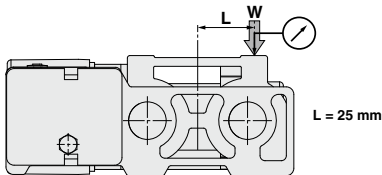
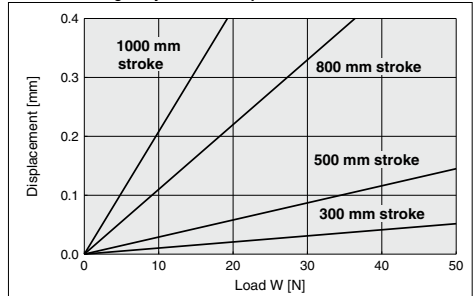

Table Displacement (Reference Value)

* Amount of displacement when the load is offset by "L" from the center of the table.



Load center of gravity located at a position offset when L = 25 mm



Electric Actuator/Guide Rod Slider Belt Drive

LEL Series LEL25



How to Order

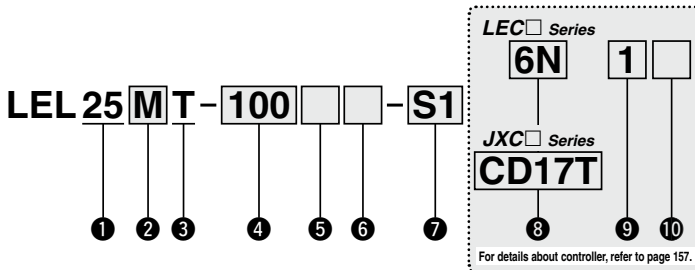

① Size

25

② Bearing type

M	Sliding bearing
L	Ball bushing bearing

③ Equivalent lead

T	48 mm
---	-------

④ Stroke^{*1 *2} [mm]

Stroke	None	
	Size	Applicable stroke
100 to 1000	25	100, 200, 300, 400, 500, 600, 700, 800, 900, 1000 (100 mm increments)

⑤ Motor option

Nll	Without option
B	With lock
C	With motor cover ^{*3}

⑥ Switch rail option^{*4}

Nll	Without option
R	With magnet/switch rail

⑦ Actuator cable type/length^{*6}

Standard cable [m]		Robotic cable [m]			
Nll	None	R1	1.5	RA	10 ^{*5}
S1	1.5	R3	3	RB	15 ^{*5}
S3	3	R5	5	RC	20 ^{*5}
S5	5	R8	8 ^{*5}		

LEC Series (For details, refer to page 157-1.)

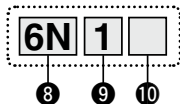

8 Controller type*7

Nil	Without controller	
6N	LECP6	NPN
6P	(Step data input type)	PNP
1N	LECP1	NPN
1P	(Programless type)	PNP
MJ	LECPMJ	—
	(CC-Link direct input type)	

9 I/O cable length*8, Communication plug

Nil	Without cable (Without communication plug connector)*10
1	1.5 m
3	3 m*9
5	5 m*9
S	Straight type communication plug connector*10
T	T-branch type communication plug connector*10

10 Controller mounting

Nil	Screw mounting
D	DIN rail mounting*11



JXC Series (For details, refer to page 157-1.)

8 Controller

Nil	Without controller
C□1□□	With controller



Communication protocol

E	EtherCAT®
9	EtherNet/IP™
P	PROFINET
D	DeviceNet™
L	IO-Link

Mounting

7	Screw mounting
8 *11	DIN rail mounting

• For single axis

Communication plug connector for DeviceNet™12

Nil	Without plug connector
S	Straight type
T	T-branch type



*1 Please consult with SMC as all non-standard and non-made-to-order strokes are produced as special orders.

*2 The strokes in bold are produced upon receipt of order.

*3 When [With lock] is selected, [With motor cover] cannot be selected.

*4 After purchasing the "Nil" type, the magnet and switch rail cannot be attached afterwards.

*5 Produced upon receipt of order (Robotic cable only)

*6 The standard cable should only be used on fixed parts.

For use on moving parts, select the robotic cable.

*7 For details about controller and compatible motor, refer to the compatible controller on the next page.

*8 When "Without controller" is selected for controller types, I/O cable length cannot be selected.

*9 When "Pulse input type" is selected for controller/driver types, pulse input usable only with differential. Only 1.5 m cables usable with open collector.

*10 For the LECPMJ, only "Nil", "S" and "T" are selectable since I/O cable is not included.

*11 DIN rail is not included. Order it separately.

*12 Select "Nil" for anything other than DeviceNet™.

⚠ Caution

[CE-compliant products]

① EMC compliance was tested by combining the electric actuator LEL series and the controller LEC/JXC series.

The EMC depends on the configuration of the customer's control panel and the relationship with other electrical equipment and wiring. Therefore, conformity to the EMC directive cannot be certified for SMC components incorporated into the customer's equipment under actual operating conditions. As a result, it is necessary for the customer to verify conformity to the EMC directive for the machinery and equipment as a whole.

② CC-Link direct input type (LECPMJ) is not CE-compliant.

[UL-compliant products]

When conformity to UL is required, the electric actuator and controller/driver should be used with a UL1310 Class 2 power supply.

The actuator and controller/driver are sold as a package.

Confirm that the combination of the controller/driver and the actuator is correct.

<Check the following before use.>

- ① Check the actuator label for model number. This matches the controller/driver.
- ② Check Parallel I/O configuration matches (NPN or PNP).

LEL25MT-100

①

②

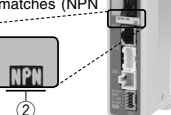



* Refer to the Operation Manual for using the products. Please download it via our website, <https://www.smcworld.com>

LEL Series





Step Motor (Servo/24 VDC)

Compatible Controller

LEC□ Series

Type	Step data input type 	CC-Link direct input type 	Programless type 
	Series	LECP6	LECPMJ
Features	Value (Step data) input Standard controller	CC-Link direct input	Capable of setting up operation (step data) without using a PC or teaching box
Compatible motor	Step motor (Servo/24 VDC)		
Maximum number of step data	64 points		14 points
Power supply voltage	24 VDC		
Reference page	Page 560	Page 600	Page 576

JXC□ Series

Type	EtherCAT® direct input type 	EtherNet/IP™ direct input type 	PROFINET direct input type 	DeviceNet™ direct input type 	IO-Link direct input type 
	Series	JXCE1	JXC91	JXCP1	JXCD1
Features	EtherCAT® direct input	EtherNet/IP™ direct input	PROFINET direct input	DeviceNet™ direct input	IO-Link direct input
Compatible motor	Step motor (Servo/24 VDC)				
Maximum number of step data	64 points				
Power supply voltage	24 VDC				
Reference page	Page 603-5				

Specifications

Step Motor (Servo/24 VDC)

Model		LEL25M	LEL25L
Actuator specifications	Stroke [mm] ^{Note 1)}	(100), (200), 300, 400, 500, 600 (700), (800), (900), (1000)	
	Work load [kg] ^{Note 2)}	Horizontal (Wall mounting) 3 (2.5)	5 (5)
	Speed [mm/s] ^{Note 2)}	48 to 500	
	Max. acceleration/deceleration [mm/s ²]	3000	
	Positioning repeatability [mm]	±0.08	
	Lost motion [mm] ^{Note 3)}	0.1 or less	
	Equivalent lead [mm]	48	
	Impact/Vibration resistance [m/s ²] ^{Note 4)}	50/20	
	Actuation type	Belt	
	Guide type	Sliding bearing	Ball bushing bearing
	Allowable external force [N] ^{Note 5)}	5	
	Operating temperature range [°C]	5 to 40	
Operating humidity range [%RH]	90 or less (No condensation)		
Electric specifications	Motor size	□42	
	Motor type	Step motor (Servo/24 VDC)	
	Encoder	Incremental A/B phase (800 pulse/rotation)	
	Rated voltage [V]	24 VDC ±10%	
	Power consumption [W] ^{Note 6)}	32	
	Standby power consumption when operating [W] ^{Note 7)}	16	
	Max. instantaneous power consumption [W] ^{Note 8)}	60	
Lock unit specifications	Type ^{Note 9)}	Non-magnetizing lock	
	Holding force [N]	19	
	Power consumption [W] ^{Note 10)}	5	
	Rated voltage [V]	24 VDC ±10%	

Note 1) Strokes shown in () are produced upon receipt of order. Please consult with SMC as all non-standard and non-made-to-order strokes are produced as special orders.

Note 2) Speed changes according to the work load. Check "Speed-Work Load Graph (Guide)" on page 155. The work load changes according to the stroke and work load mounting condition.

Check "Dynamic Allowable Moment" graph on page 153. Furthermore, if the cable length exceeds 5 m, then it will decrease by up to 10% for each 5 m.

Note 3) A reference value for correcting an error in reciprocal operation.

Note 4) Impact resistance: No malfunction occurred when the actuator was tested with a drop tester in both the stroke direction and a perpendicular direction to the stroke. (The test was performed with the actuator in the initial state.)

Vibration resistance: No malfunction occurred in a test ranging between 45 to 2000 Hz, when the actuator was tested in both stroke direction and a perpendicular direction to the stroke. (The test was performed with the actuator in the initial state.)

Note 5) Allowable external resistance is the allowable resistance when flexible moving tube or similar is used.

Note 6) The power consumption (including the controller) is for when the actuator is operating.

Note 7) The standby power consumption when operating (including the controller) is for when the actuator is stopped in the set position during operation.

Note 8) The maximum instantaneous power consumption (including the controller) is for when the actuator is operating. This value can be used for the selection of the power supply.

Note 9) With lock only

Note 10) For an actuator with lock, add the power consumption for the lock.

Actuator Product Weight

Stroke [mm]		(100)	(200)	300	400	500	600	(700)	(800)	(900)	(1000)
Product weight [kg]	LEL25M	2.13	2.47	2.82	3.17	3.52	3.87	4.21	4.56	4.91	5.26
	LEL25L	2.38	2.72	3.07	3.42	3.77	4.12	4.47	4.82	5.17	5.52
Additional weight with lock [kg]						0.26					
Additional weight with cover [kg]						0.04					

Construction

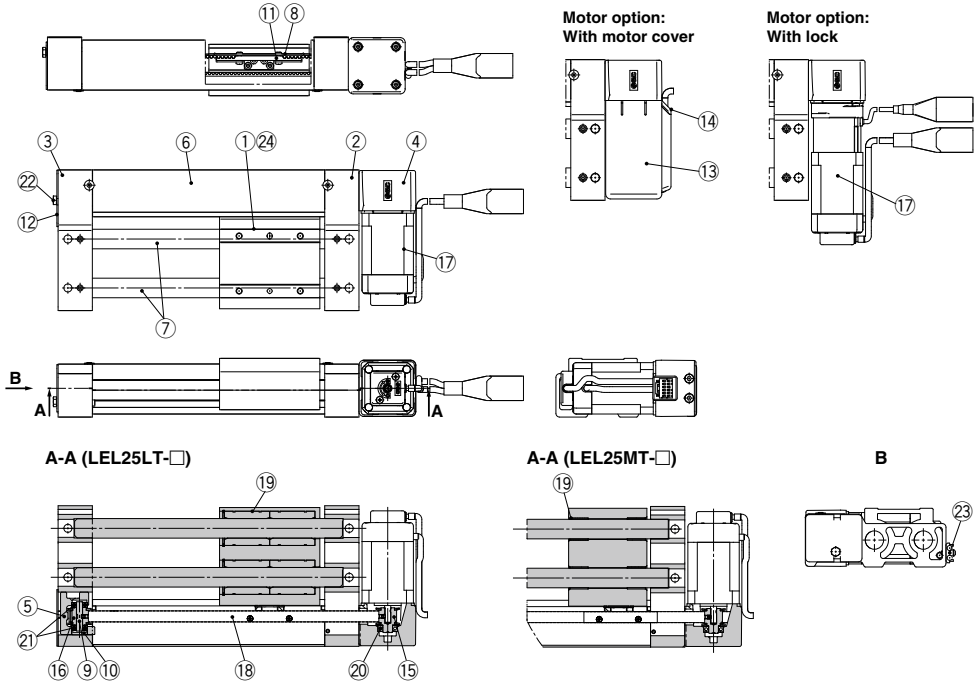

Component Parts

No.	Description	Material	Note
1	Table	Aluminum alloy	Anodized
2	Motor end plate	Aluminum alloy	Anodized
3	End plate	Aluminum alloy	Anodized
4	Motor mount	Aluminum die-cast	Painting
5	Pulley holder	Aluminum alloy	
6	Belt cover	Aluminum alloy	Anodized
7	Guide rod	Carbon steel	Hard chrome plating
8	Belt holder	Carbon steel	Chromating
9	Pulley shaft	Stainless steel	
10	Spacer	Aluminum alloy	
11	Belt stopper	Aluminum alloy	
12	Tension plate	Aluminum alloy	Anodized
13	Motor cover	Synthetic resin	"With motor cover" only
14	Grommet	Synthetic resin	"With motor cover" only
15	Motor pulley	Aluminum alloy	Anodized
16	End pulley	Aluminum alloy	Anodized
17	Motor	—	
18	Belt	—	
19	Bushing	—	
20	Ball bushing bearing	—	
21	Bearing	—	
22	Hexagon bolt	Carbon steel	Chromating
23	Switch rail	Aluminum alloy	"With magnet/switch rail" only
24	Magnet	—	"With magnet/switch rail" only

LEL Series

Step Motor (Servo/24 VDC)

Dimensions

LEL25^MT

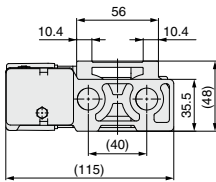
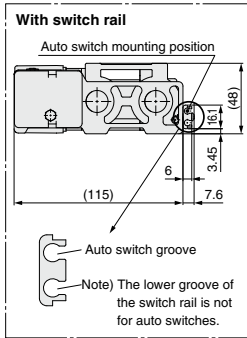

With motor cover

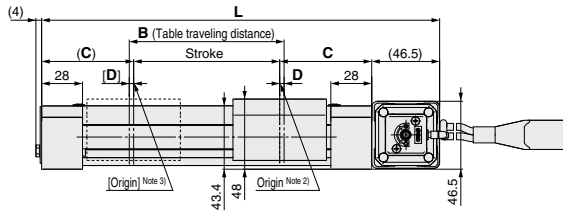
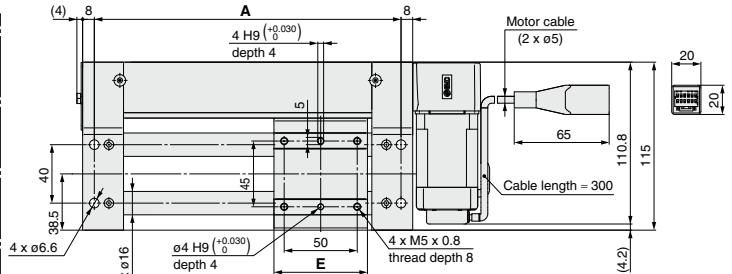
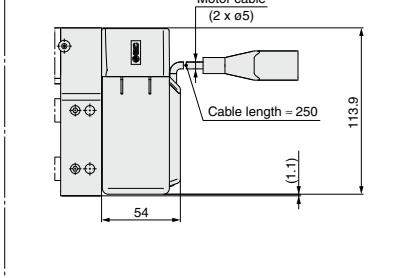

With lock

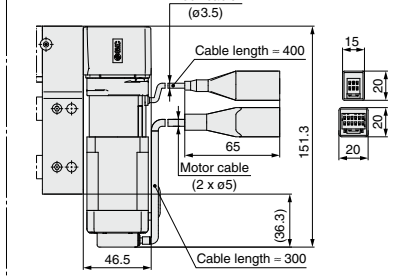

Note 1) Distance within which the table can move when it returns to origin. Make sure a workpiece mounted on the table does not interfere with the workpieces and facilities around the table.

Note 2) Position after return to origin.

Note 3) [] for when the direction of return to origin has changed.

Model	L	L*	A	B	C	D	E
LEL25MT-100□□-□□□□	272.5	280	210	106	63	3	64
LEL25MT-200□□-□□□□	372.5	380	310	206			
LEL25MT-300□□-□□□□	472.5	480	410	306			
LEL25MT-400□□-□□□□	572.5	580	510	406			
LEL25MT-500□□-□□□□	672.5	680	610	506			
LEL25MT-600□□-□□□□	772.5	780	710	606			
LEL25MT-700□□-□□□□	872.5	880	810	706			
LEL25MT-800□□-□□□□	972.5	980	910	806			
LEL25MT-900□□-□□□□	1072.5	1080	1010	906			
LEL25MT-1000□□-□□□□	1172.5	1180	1110	1006			
LEL25LT-100□□-□□□□	292.5	300	230	108	73	4	82
LEL25LT-200□□-□□□□	392.5	400	330	208			
LEL25LT-300□□-□□□□	492.5	500	430	308			
LEL25LT-400□□-□□□□	592.5	600	530	408			
LEL25LT-500□□-□□□□	692.5	700	630	508			
LEL25LT-600□□-□□□□	792.5	800	730	608			
LEL25LT-700□□-□□□□	892.5	900	830	708			
LEL25LT-800□□-□□□□	992.5	1000	930	808			
LEL25LT-900□□-□□□□	1092.5	1100	1030	908			
LEL25LT-1000□□-□□□□	1192.5	1200	1130	1008			

* With motor cover

Solid State Auto Switch Direct Mounting Type

D-M9N(V)/D-M9P(V)/D-M9B(V)



Grommet

- 2-wire load current is reduced (2.5 to 40 mA).
- Using flexible cable as standard spec.



⚠ Caution

Precautions

Fix the auto switch with the existing screw installed on the auto switch body. The auto switch may be damaged if a screw other than the one supplied is used.

Auto Switch Specifications

Refer to SMC website for the details of the products conforming to the international standards.

PLC: Programmable Logic Controller

D-M9□, D-M9□V (With indicator light)						
Auto switch model	D-M9N	D-M9NV	D-M9P	D-M9PV	D-M9B	D-M9BV
Electrical entry direction	In-line	Perpendicular	In-line	Perpendicular	In-line	Perpendicular
Wiring type	3-wire				2-wire	
Output type	NPN		PNP		—	
Applicable load	IC circuit, Relay, PLC				24 VDC relay, PLC	
Power supply voltage	5, 12, 24 VDC (4.5 to 28 V)					
Current consumption	10 mA or less				—	
Load voltage	28 VDC or less		—		24 VDC (10 to 28 VDC)	
Load current	40 mA or less				2.5 to 40 mA	
Internal voltage drop	0.8 V or less at 10 mA (2 V or less at 40 mA)				4 V or less	
Leakage current	100 μA or less at 24 VDC				0.8 mA or less	
Indicator light	Red LED illuminates when turned ON.					
Standard	CE marking, RoHS					

Oilproof Heavy-duty Lead Wire Specifications

Auto switch model		D-M9N(V)	D-M9P(V)	D-M9B(V)
Sheath	Outside diameter [mm]	2.6		
Insulator	Number of cores	3 cores (Brown/Blue/Black)		2 cores (Brown/Blue)
	Outside diameter [mm]	0.88		
Conductor	Effective area [mm ²]	0.15		
	Strand diameter [mm]	0.05		
Minimum bending radius [mm] (Reference values)		17		

Note 1) Refer to Best Pneumatics No. 2-1 for solid state auto switch common specifications.
Note 2) Refer to Best Pneumatics No. 2-1 for lead wire lengths.

Weight

(g)

Auto switch model		D-M9N(V)	D-M9P(V)	D-M9B(V)
Lead wire length	0.5 m (Nii)	8	7	7
	1 m (M)	14	13	13
	3 m (L)	41	38	38
	5 m (Z)	68	63	63

Dimensions

(mm)

D-M9□

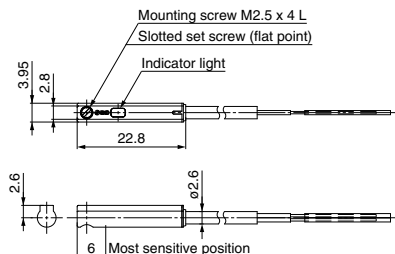

D-M9□V

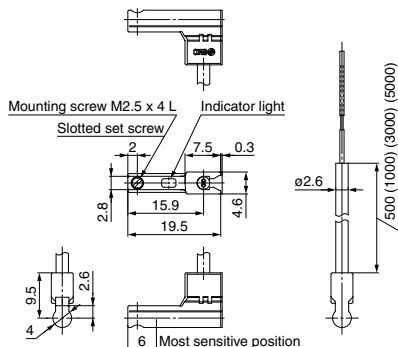

2-Color Indicator Solid State Auto Switch Direct Mounting Type

D-M9NW(V)/D-M9PW(V)/D-M9BW(V)



Refer to SMC website for the details of the products conforming to the international standards.

Grommet

- 2-wire load current is reduced (2.5 to 40 mA).
- Using flexible cable as standard spec.
- The proper operating range can be determined by the color of the light. (Red → Green ← Red)



Caution

Precautions

Fix the auto switch with the existing screw installed on the auto switch body. The auto switch may be damaged if a screw other than the one supplied is used.

Auto Switch Specifications

PLC: Programmable Logic Controller

D-M9□W, D-M9□WV (With indicator light)						
Auto switch model	D-M9NW	D-M9NWV	D-M9PW	D-M9PWV	D-M9BW	D-M9BWV
Electrical entry direction	In-line	Perpendicular	In-line	Perpendicular	In-line	Perpendicular
Wiring type	3-wire			2-wire		
Output type	NPN		PNP		—	
Applicable load	IC circuit, Relay, PLC				24 VDC relay, PLC	
Power supply voltage	5, 12, 24 VDC (4.5 to 28 V)				—	
Current consumption	10 mA or less				—	
Load voltage	28 VDC or less		—		24 VDC (10 to 28 VDC)	
Load current	40 mA or less				2.5 to 40 mA	
Internal voltage drop	0.8 V or less at 10 mA (2 V or less at 40 mA)				4 V or less	
Leakage current	100 μA or less at 24 VDC				0.8 mA or less	
Indicator light	Operating range Red LED illuminates. Proper operating range Green LED illuminates.					
Standard	CE marking, RoHS					

Oilproof Flexible Heavy-duty Lead Wire Specifications

Auto switch model		D-M9NW(V)	D-M9PW(V)	D-M9BW(V)
Sheath	Outside diameter [mm]	2.6		
Insulator	Number of cores	3 cores (Brown/Blue/Black)		2 cores (Brown/Blue)
	Outside diameter [mm]	0.88		
Conductor	Effective area [mm ²]	0.15		
	Strand diameter [mm]	0.05		
Minimum bending radius [mm] (Reference values)		17		

Note 1) Refer to Best Pneumatics No. 2-1 for solid state auto switch common specifications.
Note 2) Refer to Best Pneumatics No. 2-1 for lead wire lengths.

Weight

(g)

Auto switch model		D-M9NW(V)	D-M9PW(V)	D-M9BW(V)
Lead wire length	0.5 m (NII)	8	7	7
	1 m (M)	14	13	13
	3 m (L)	41	38	38
	5 m (Z)	68	63	63

Dimensions

(mm)

D-M9□W

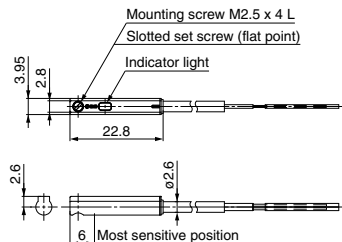

D-M9□WV

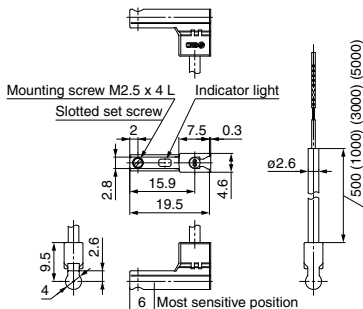

Electric Actuator/Guide Rod Slider Specific Product Precautions 1

Be sure to read this before handling the products. Refer to back page 50 for Safety Instructions and pages 3 to 8 for Electric Actuator Precautions.



Design

⚠ Caution

- 1. Do not apply a load in excess of the specification limits.**
Select a suitable actuator by work load and allowable moment. If the product is used outside of the specification limits, the eccentric load applied to the guide will be excessive and have adverse effects such as creating play on the guide, degrading accuracy and shortening the life of the product. And also when "With magnet/switch rail" option is selected, Auto switch may not detect correctly by the deflection of the guide.
- 2. Do not use the product in applications where excessive external force or impact force is applied to it.**
This can cause failure.
- 3. Because of the guide mechanism type, vibration that comes from an external source may be introduced into the workpiece during operation. Do not use this product in a location where vibration is not allowed.**
- 4. When the product repeatedly cycles with partial strokes (see the table below), operate it at a full stroke at least once every 10 dozens of cycles.**

Otherwise, lubrication can run out.

Model	Partial stroke
LEL25L	40 mm or less

Handling

⚠ Caution

- 1. Set [In position] in the step data to at least 1.**
Otherwise, completion signal of in position may not be output.
- 2. INP output signal**
 - 1) Positioning operation
When the product comes within the set range by step data [In position], the INP output signal will turn on.
Initial value: Set to [1] or higher.

Handling

⚠ Caution

- 3. Never hit at the stroke end except during return to origin.**
When incorrect instructions are inputted, such as using the product outside of the specification limits or operation outside of actual stroke through changes in the controller/driver setting and/or origin position, the table may collide against the stroke end of the actuator. Check these points before use.
If the table collides against the stroke end of the actuator, the guide, belt or internal stopper can be broken. This may lead to abnormal operation.

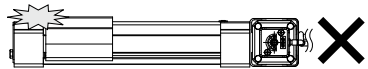

- 4. The moving force should be the initial value (100%).**
If the moving force is set below the initial value, it may cause an alarm.
- 5. The actual speed of this actuator is affected by the work load.**
When selecting a product, check the catalog for the instructions regarding selection.
- 6. Do not apply a load, impact or resistance in addition to the transferred load during return to origin.**
Additional force will cause the displacement of the origin position since it is based on detected motor torque.
- 7. Do not dent, scratch or cause other damage to the body and table mounting surfaces.**
This may cause unevenness in the mounting surface, play in the guide or an increase in the sliding resistance.
- 8. Do not apply strong impact or an excessive moment while mounting a workpiece.**
If an external force over the allowable moment is applied, it may cause play in the guide or an increase in the sliding resistance.
- 9. Keep the flatness of the mounting surface 0.2 mm or less.**
Unevenness of a workpiece or base mounted on the body of the product may cause play in the guide and an increase in the sliding resistance.
- 10. When mounting the product, keep a 40 mm or longer diameter for bends in the cable.**
- 11. Do not hit the table with the workpiece in the positioning operation and positioning range.**
- 12. Hold by the end plates when moving the body. Do not hold the belt cover.**

LEL Series

Electric Actuator/Guide Rod Slider Specific Product Precautions 2

Be sure to read this before handling the products. Refer to back page 50 for Safety Instructions and pages 3 to 8 for Electric Actuator Precautions.



Handling

⚠ Caution

13. When mounting the product, use screws with adequate length and tighten them with adequate torque.

Tightening the screws with a higher torque than recommended may cause a malfunction, whilst the tightening with a lower torque can cause the displacement of the mounting position or in extreme conditions the actuator could become detached from its mounting position.

Body fixed

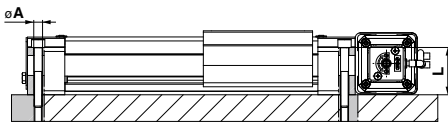

Model	Screw size	Max. tightening torque [N·m]	φA [mm]	L [mm]
LEL25	M6	5.2	6.6	35.5

Workpiece fixed

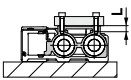

Model	Screw size	Max. tightening torque [N·m]	L (Max. screw-in depth) [mm]
LEL25	M5 x 0.8	3	8

To prevent the workpiece retaining screws from touching the body, use screws that are 0.5 mm or shorter than the maximum screw-in depth. If long screws are used, they can touch the body and cause a malfunction.

14. Do not operate by fixing the table and moving the actuator body.
15. The belt drive actuator cannot be used vertically for applications.
16. Check the specifications for the minimum speed of each actuator.
Otherwise, unexpected malfunctions, such as knocking, may occur.
17. In the case of the belt drive actuator, vibration may occur during operation at speeds within the actuator specifications, this could be caused by the operating conditions. Change the speed setting to a speed that does not cause vibration.

Maintenance

⚠ Warning

Maintenance frequency

Perform maintenance according to the table below.

Frequency	Appearance check	Internal check	Belt check
Inspection before daily operation	○	—	—
Inspection every 6 months/1000 km/ 5 million cycles*	○	○	○

* Select whichever comes first.

• Items for visual appearance check

1. Loose set screws, Abnormal dirt
2. Check of flaw and cable joint
3. Vibration, Noise

• Items for internal check

1. Lubricant condition on moving parts.
2. Loose or mechanical play in fixed parts or fixing screws.

• Items for belt check

Stop operation immediately and replace the belt when belt appear to be below. Further, ensure your operating environment and conditions satisfy the requirements specified for the product.

a. Tooth shape canvas is worn out.

Canvas fiber becomes fuzzy. Rubber is removed and the fiber becomes whitish. Lines of fibers become unclear.

b. Peeling off or wearing of the side of the belt

Belt corner becomes round and frayed thread sticks out.

c. Belt partially cut

Belt is partially cut. Foreign matter caught in teeth other than cut part causes flaw.

d. Vertical line of belt teeth

Flaw which is made when the belt runs on the flange.

e. Rubber back of the belt is softened and sticky.

f. Crack on the back of the belt