

Vacuum Switch Diaphragm Type

ZSM1-115/121 Series



Specifications

Model	ZSM1-115	ZSM1-121
Switch specifications	Solid state	Contact (Reed switch)
Fluid	Air/Inert gas	
Max. operating pressure	0.5 MPa	
Regulating pressure range	-27 to -80 kPa	
Hysteresis	Max. 15 kPa	Max. 20 kPa
Repeatability	±10% or less	
Ambient and fluid temperature	-5 to 60°C (No freezing)	
Supply voltage	4.5 to 28 VDC	100 VAC/DC or less
Indicator light	ON: When output is ON.	
Lead wire	3	2
Port size	R 1/8	
Weight	65 g	

Electrical Specifications

ZSM1-115

Supply voltage	4.5 to 28 VDC
Output (Open collector)	28 V, Max. 40 mA
Current consumption	10 mA or less (24 VDC)

ZSM1-121

Supply voltage	100 VAC/DC
Max. operating current range	24 V or less: 50 mA, 48 V: 40 mA, 100 V: 20 mA
Max. contact capacity	AC 2 VA, 2 W DC

How to Order

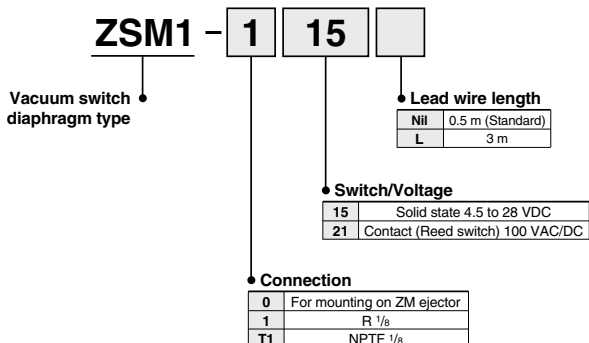

Vacuum Switch Diaphragm Type **ZSM1-115/121 Series**

Internal Circuit

ZSM1-115

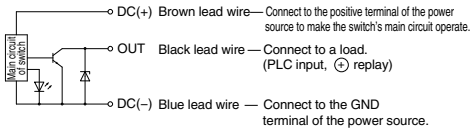

ZSM1-121

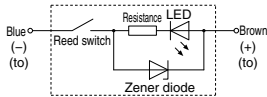

Wiring

ZSM1-115

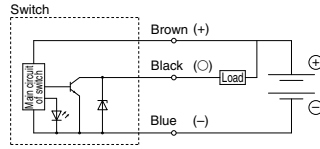

Dimensions

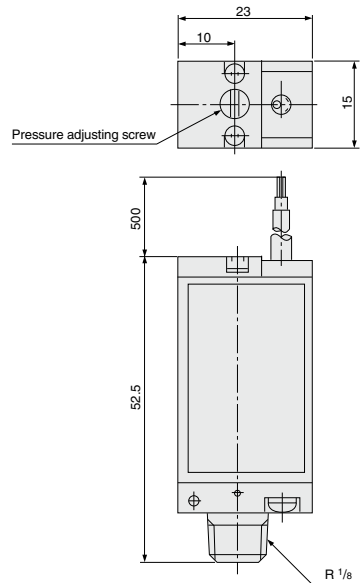

ZSM1-115

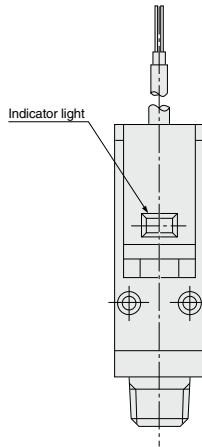

ZSM1-121

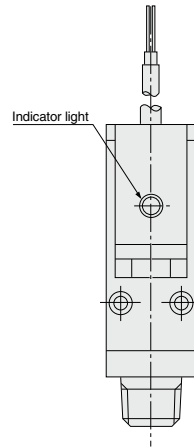

ZSE20
ISE20

ZSE30
ISE30

ZSE40
ISE40

ZSE10
ISE10

ISE70

ZSE80
ISE80

PS

ISA3

ISA2

ISE35

PSE

IS

ISG

ZSM1



ZSM1-115/121 Series Specific Product Precautions

Be sure to read this before handling the products.

Refer to back page 50 for Safety Instructions and pages 11 and 12 for Pressure Switch Precautions.

Wiring

⚠ Warning

- Do not apply excessive pulling force on the lead wire. It may cause a malfunction or damage.
- Wiring of ZSM1-121**
Switches may be connected in series, voltage drop will be increased by the LED's internal resistance (2 V drop per each). Use switches within the specified range of min. operating voltage.
- Diaphragm switches have no built-in contact protection circuits. Use switches with contact protection box (part no. CD-P11) with inductive loads or 5 m or more lead wire length.
- Internal circuit of contact protection box**

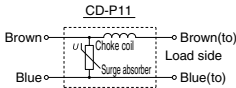

5. How to connect the contact protection box

Connect the lead wires from the body and the contact protective box side indicated "SWITCH".

Lead wire should be as short as possible, within 1 m.

Installation/Piping

⚠ Caution

- When piping switch by hand, hold body. Electrical wire must not be subjected to excessive force.
- Do not drop nor apply excessive force. It may cause malfunction or damage.
- Tighten switch by applying the wrench on the fitting part. Turning it by applying a wrench on the main body may cause damage to the product.
- Mounting is possible in either horizontal or vertical orientation.

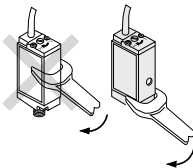

Pressure Source

⚠ Warning

- Do not absorb water, etc. when using as an adsorption confirmation switch. It may result in a malfunction or damage.
- Operating fluids are either air or inert gas exclusively. It cannot be used with corrosive fluids.

Pressure Setting

⚠ Warning

1. Setting of vacuum pressure

Set the possible minimum pressure for adsorption when used for adsorption confirmation. If setting the pressure lower than that, switch becomes ON in case when adsorption is not complete. If setting the pressure higher than that, switch does not become ON though it is absorbing workpieces properly.

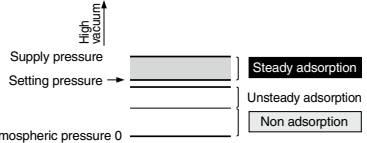

2. Hysteresis

Hysteresis is the pressure difference between the ON pressure and the OFF pressure of the output signal. The set pressure is the pressure selected to switch from OFF to ON condition.

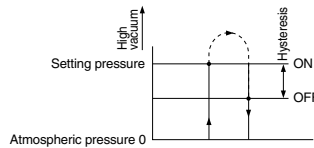

3. Number of rotations of pressure adjusting screw

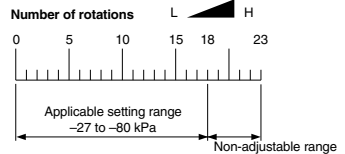

Max. number of rotations are 18.

⚠ Caution

1. How to Set Vacuum Pressure

The pressure setting trimmer is used to set the on-pressure. Clockwise rotation increases the on-pressure setting.

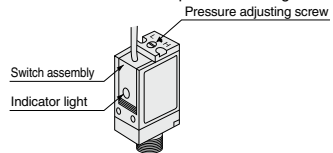

Operating Environment

⚠ Warning

- Not able to use it under the influence of a magnetic field. Affected by the magnetic field, and result in a malfunction.
- Do not use in such an environment where water or oil is splashed. Since it is the open type construction, if water or oil make an ingress into the internal parts, the electric circuit will be corroded and may result in malfunction or damage.
- Never use switch in an environment where flammable fluid or gas is used. It may result in an explosive disaster, since it is not explosion-proof construction.