

# Vacuum Pad

## ZP3E Series

ø32, ø40, ø50, ø63, ø80, ø100, ø125

Flat Type

With Groove

Bellows Type

With Groove

RoHS

Stability of suction position,  
improved ease of removal

Number of mounting screws  
reduced (4 pcs. → 1 pc.)

Pad and metal parts can be  
disposed of separately.

Improved uneven workpiece  
surface suction.



ZP3

ZP3E

ZP2

ZP2V

ZP

ZPT

ZPR

XT661

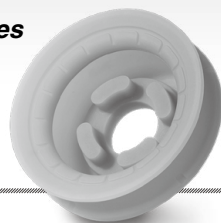

## Stability of suction position

Groove and rib formed to adsorb with entire surface

- Groove on the adsorption surface secures the interior space.
- Ribs reduce the inclinations during transport of workpiece.

ZP (Current model/Bellows pad)

ZP3E (Bellows pad)

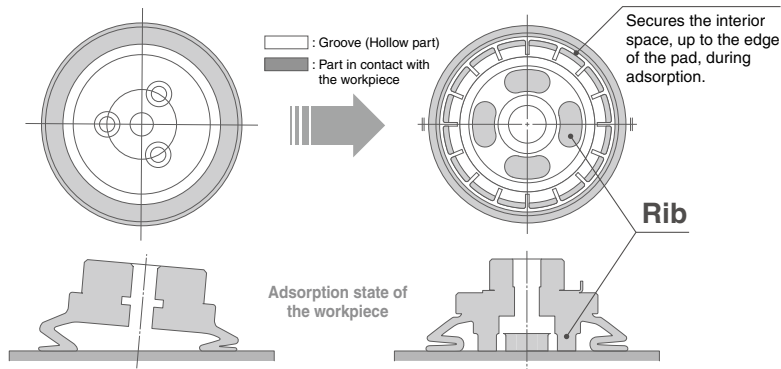

## Improved ease of removal

### With groove

Dents and bumps on the adsorption surface prevent the workpiece from sticking to it. This facilitates easy removal.

### Shot-blasted

Micro-dents and bumps are formed on the adsorption surface. Workpieces can be removed easily.

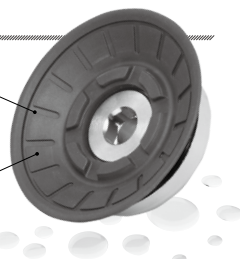

## The number of mounting screws reduced

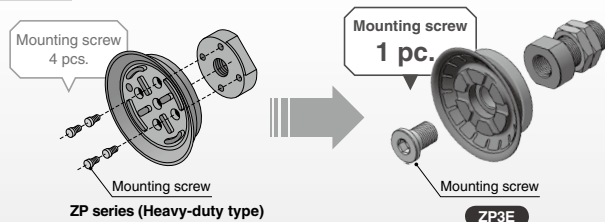

## Can be disposed of separately.

The rubber pad and metal part can be separated.

The metal parts and rubber parts can be separated completely.

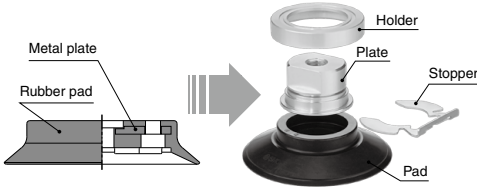

ZP series (Heavy-duty type)

**ZP3E**

## Mark-free

For use where adsorption marks must not be left on workpieces.

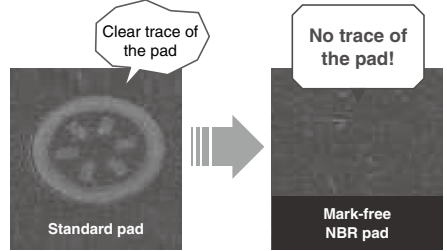

## Suction flow rate increased

Applicable to workpieces with a large suction flow rate and high permeability, and vacuum blow pumps with large suction flow rates.

**Double suction port size**

Pad diameter:  $\phi 63$ ,  $\phi 80$   
(Compared with the ZP series)

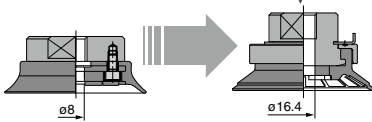

Pad diameter	ZP (Current model)		ZP3E	
	Suction port	Area [mm <sup>2</sup> ]	Suction port	Area [mm <sup>2</sup> ]
$\phi 32$	—	—	$\phi 8.4$	55.4
$\phi 40$	$\phi 6$	28.3		
$\phi 50$	$\phi 8$	50.2	$\phi 16.4$	211
$\phi 63$				
$\phi 80$				
$\phi 100$	$\phi 10$	78.52		
$\phi 125$	—	—	—	—

## Ball joint type pad weight reduced

Weight reduced by changing the internal structure and materials

\* The pad material when weight was measured is NBR.

Weight reduced by up to **290 g**

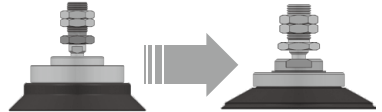

Pad diameter	ZP2/Flat type	ZP3E/Flat type with groove
	Weight [g]	Weight [g]
$\phi 32$	—	56
$\phi 40$	91	57
$\phi 50$	110	75
$\phi 63$	230	150
$\phi 80$	270	160
$\phi 100$	430	190
$\phi 125$	560	270

## Direct mounting with metal thread added

Direct mounting

- Reduced in height
- Easy mounting with tightening with a hexagonal wrench

Seal washer

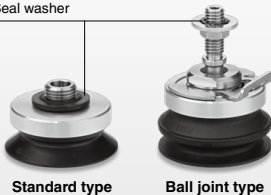

Standard type

Ball joint type

**ZP3E**

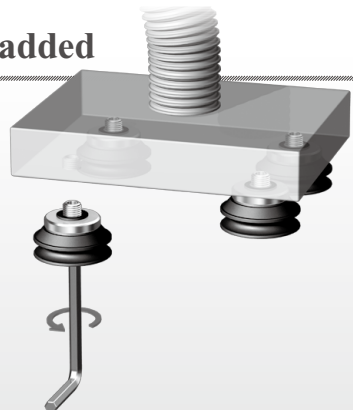

ZP3

ZP3E

ZP2

ZP2V

ZP



ZPT

ZPR

XT661

**Pad Unit Variations**



Form	Pad diameter							Material	Page
	ø32	ø40	ø50	ø63	ø80	ø100	ø125		
 <b>ZP3E-□UM-□</b> <b>Flat type with groove</b> For adsorption of general workpieces. To be used when adsorption surface of the workpiece is flat and not deformed.	●	●	●	●	●	●	●	NBR Silicone rubber Urethane rubber FKM Mark-free NBR	404
 <b>ZP3E-□BM-□</b> <b>Bellows type with groove</b> To be used when adsorption surface of the workpiece is slanted.	●	●	●	●	●	●	●		404

**INDEX**

**Vacuum Pad Flat Type with Groove/Bellows Type with Groove**

ø32, ø40, ø50, ø63, ø80, ø100, ø125

<ul style="list-style-type: none"> <li>■ <b>Model Selection</b> ..... P.382                             <ul style="list-style-type: none"> <li>1. Features and Precautions for Vacuum Adsorption ..... P.383</li> <li>2. Vacuum Pad Selection ..... P.383</li> <li>3. Selection of Vacuum Ejector and Vacuum Switching Valve ..... P.392</li> <li>4. Leakage Volume during Workpiece Adsorption ..... P.392</li> <li>5. Adsorption Response Time ..... P.393</li> <li>6. Precautions on Vacuum Equipment Selection and SMC's Proposal. P.395</li> <li>7. Vacuum Equipment Selection Example ..... P.398</li> <li>8. Data ..... P.399</li> </ul> </li> <li>■ <b>Flat Type Pad/Bellows Type Pad with Groove</b> · P.404                             <ul style="list-style-type: none"> <li>Pad Unit: Flat Type with Groove ..... P.404</li> <li>Pad Unit: Bellows Type with Groove ..... P.406</li> </ul> </li> <li>■ <b>Vertical Vacuum Inlet/With Adapter</b> ..... P.408                             <ul style="list-style-type: none"> <li>With Set Screw: Flat Type with Groove ..... P.408</li> <li>With Male Thread Adapter: Flat Type with Groove ..... P.410</li> <li>With Female Thread Adapter: Flat Type with Groove ..... P.412</li> <li>With Set Screw: Bellows Type with Groove ..... P.414</li> <li>With Male Thread Adapter: Bellows Type with Groove ..... P.416</li> <li>With Female Thread Adapter: Bellows Type with Groove ..... P.418</li> </ul> </li> <li>■ <b>Lateral Vacuum Inlet/With Adapter</b> ..... P.420                             <ul style="list-style-type: none"> <li>With Male Thread Adapter: Flat Type with Groove ..... P.420</li> <li>With Female Thread Adapter: Flat Type with Groove ..... P.422</li> <li>With Male Thread Adapter: Bellows Type with Groove ..... P.424</li> <li>With Female Thread Adapter: Bellows Type with Groove ..... P.426</li> </ul> </li> <li>■ <b>Vertical Vacuum Inlet/With Buffer</b> ..... P.428                             <ul style="list-style-type: none"> <li>With Buffer: Flat Type with Groove ..... P.428</li> <li>With Buffer: Bellows Type with Groove ..... P.430</li> </ul> </li> </ul>	<ul style="list-style-type: none"> <li>■ <b>Lateral Vacuum Inlet/With Buffer</b> .... P.432                             <ul style="list-style-type: none"> <li>With Buffer: Flat Type with Groove ..... P.432</li> <li>With Buffer: Bellows Type with Groove ..... P.434</li> </ul> </li> <li>■ <b>Vertical Vacuum Inlet/With Ball Joint Adapter</b> .... P.436                             <ul style="list-style-type: none"> <li>With Ball Joint Adapter: Flat Type with Groove ..... P.436</li> <li>With Ball Joint Male Thread Adapter: Flat Type with Groove ..... P.439</li> <li>With Ball Joint Female Thread Adapter: Flat Type with Groove ... P.441</li> <li>With Ball Joint Adapter: Bellows Type with Groove ..... P.443</li> <li>With Ball Joint Male Thread Adapter: Bellows Type with Groove ..... P.445</li> <li>With Ball Joint Female Thread Adapter: Bellows Type with Groove ... P.447</li> </ul> </li> <li>■ <b>Lateral Vacuum Inlet/With Ball Joint Adapter</b> .... P.449                             <ul style="list-style-type: none"> <li>With Ball Joint Male Thread Adapter: Flat Type with Groove ..... P.449</li> <li>With Ball Joint Female Thread Adapter: Flat Type with Groove ..... P.452</li> <li>With Ball Joint Male Thread Adapter: Bellows Type with Groove ..... P.454</li> <li>With Ball Joint Female Thread Adapter: Bellows Type with Groove ..... P.456</li> </ul> </li> <li>■ <b>Vertical Vacuum Inlet/With Ball Joint Buffer</b> .... P.458                             <ul style="list-style-type: none"> <li>With Ball Joint Buffer: Flat Type with Groove ..... P.458</li> <li>With Ball Joint Buffer: Bellows Type with Groove ..... P.461</li> </ul> </li> <li>■ <b>Lateral Vacuum Inlet/With Ball Joint Buffer</b> .... P.463                             <ul style="list-style-type: none"> <li>With Ball Joint Buffer: Flat Type with Groove ..... P.463</li> <li>With Ball Joint Buffer: Bellows Type with Groove ..... P.466</li> </ul> </li> </ul>
<ul style="list-style-type: none"> <li>Construction ..... P.468</li> <li>Component Part No. .... P.471</li> <li>How to Replace the Pad ..... P.479</li> <li>Component Parts: Dimensions ..... P.480</li> <li>Ball Joint Assembly/Unit Part No. .... P.487</li> <li>Ball Joint Buffer Unit Part No. .... P.492</li> </ul>	



With Adapter Variations

Standard Type



Ball Joint Type



Vacuum inlet direction Mounting	Mounting thread size	Buffer attachment	Page
<b>Vertical</b> Male thread/Direct mounting ZP3E-T□□□-□	M10 M16	Without buffer	408
<b>Vertical</b> Male thread/Plate connection ZP3E-T□□□-□	M14 M16		408
<b>Vertical</b> Female thread mounting ZP3E-T□□□-□	M8 M10 M12 M18		408
<b>Lateral</b> Male thread mounting ZP3E-Y□□□-□	M14 M16	Without buffer	420
<b>Lateral</b> Female thread mounting ZP3E-Y□□□-□	M8 M12		420
<b>Vertical</b> Male thread mounting ZP3E-T□□□JB□	M18 M22	With buffer Stroke · 10 mm · 30 mm · 50 mm	428
<b>Lateral</b> Male thread mounting ZP3E-Y□□□JB□			432

Vacuum inlet direction Mounting	Mounting thread size	Buffer attachment	Page
<b>Vertical</b> Male thread/Direct mounting ZP3E-TF□□□□-□	M6 M12	Without buffer	436
<b>Vertical</b> Male thread/Plate connection ZP3E-TF□□□□-□	M14 M16		436
<b>Vertical</b> Female thread mounting ZP3E-TF□□□□-□	M8 M12		436
<b>Lateral</b> Male thread mounting ZP3E-YF□□□□-□	M14 M16	Without buffer	449
<b>Lateral</b> Female thread mounting ZP3E-YF□□□□-□	M8 M12		449
<b>Vertical</b> Male thread mounting ZP3E-TF□□□□JB□	M18 M22	With buffer Stroke · 10 mm · 30 mm · 50 mm	458
<b>Lateral</b> Male thread mounting ZP3E-YF□□□□JB□			463

ZP3

ZP3E

ZP2

ZP2V

ZP

ZPT

ZPR

XT661

# Vacuum Equipment Model Selection

## CONTENTS

### **1 Features and Precautions for Vacuum Adsorption** Page 383

### **2 Vacuum Pad Selection** Page 383

- Vacuum Pad Selection Procedures
- Points for Selecting Vacuum Pads
  - A. Shear Force and Moment Applied to Vacuum Pad
  - B. Theoretical Lifting Force
- Vacuum Pad Type
- Vacuum Pad Material
- Rubber Material and Properties
- Color and Identification
- Buffer Attachment
- Pad Selection by Workpiece Type

### **3 Selection of Vacuum Ejector and Vacuum Switching Valve** Page 392

- Calculating Vacuum Ejector and Switching Valve Size with the Formula

### **4 Leakage Volume during Workpiece Adsorption** Page 392

- Leakage Volume from Conductance of Workpiece
- Leakage Volume from Suction Test

### **5 Adsorption Response Time** Page 393

- Relationship between Vacuum Pressure and Response Time after Supply Valve (Switching Valve) is Operated
- Calculating Adsorption Response Time with the Formula
- Adsorption Response Time from the Selection Graph

### **6 Precautions on Vacuum Equipment Selection and SMC's Proposal** Page 395

- Safety Measures
- Precautions on Vacuum Equipment Selection
- Vacuum Ejector or Pump and Number of Vacuum Pads
- Vacuum Ejector Selection and Handling Precautions
- Supply Pressure of Vacuum Ejector
- Timing for Vacuum Generation and Suction Verification
  - A. Timing for Vacuum Generation
  - B. Suction Verification
  - C. Set Pressure for Vacuum Pressure Switch
- Dust Handling of Vacuum Equipment

### **7 Vacuum Equipment Selection Example** Page 398

- Transfer of Semiconductor Chips

### **8 Data** Page 399

- Selection Graph
- Glossary of Terms
- Countermeasures for Vacuum Adsorption System Problems (Troubleshooting)
- Non-conformance Examples
- Time of Replacement of Vacuum Pad

## 1 Features and Precautions for Vacuum Adsorption

Vacuum adsorption system as a method to hold a workpiece has the following features.

- Compared with the mechanical gripper and other similar products, it has a simpler construction and fewer moving parts.
- Workpieces with any shape are possible if they have an adsorption surface.
- No need for accurate positioning
- Compatible with soft and easily-deformed workpieces

However, special care is required in the following conditions.

- Be careful and do not drop the workpiece caused by the transfer conditions (acceleration, vibration, or impact).
- The piping may be clogged by liquid or particles suctioned near the workpiece.
- It is necessary to place the pad in the appropriate position to transfer heavy objects.
- The vacuum pad (rubber) may deteriorate depending on the operating environment and conditions.
- As the product life (replacement period) depends on the customer's operating conditions, it cannot be estimated beforehand.

A suction test is recommended with actual equipment before selecting the product model.

Consider the features and precautions shown above, and perform periodic maintenance and take corrective actions for the operating conditions.

## 2 Vacuum Pad Selection

Before selecting the product model, read "How to Order", "Vacuum Equipment Precautions", and "Safety Instructions."

The operating range and performance data and values shown in this catalog are the guidelines for selecting a model. In actual operation, there is a possibility that a general specification is not applicable due to unexpected factors or conditions.

Before using the product, determine whether or not the values shown in this catalog are applicable to expected usage, and accept all danger and responsibility caused thereby. SMC cannot take any responsibility for any items which are not shown in this catalog.

### ● Vacuum Pad Selection Procedures

- 1) Fully taking into account the balance of a workpiece, identify the suction position, number of pads and applicable pad diameter (or pad area).
  - \* When selecting the model based on product weight, there is a possibility that the workpiece cannot be adsorbed or it is dropped depending on the operating conditions (workpiece balance, transfer acceleration, pressure or friction force applied to the workpiece during transfer etc.).
- 2) Find the theoretical lifting force from the identified adsorption area (pad area x number of pads) and vacuum pressure, and then find the lifting force considering actual lifting and safety factor of transfer condition.
  - \* Use the calculated values as a guideline (reference value) and check the actual values by performing a suction test as necessary.
- 3) Determine the necessary pad diameter (pad area) and suction position (workpiece balance) so that the lift force is larger than weight of the workpiece.
- 4) Determine the pad form and materials, and the necessity of buffer based on the operating environment, and the workpiece shape and materials.
- 5) This product is not designed to hold a vacuum.
- 6) Perform a suction test with actual equipment to determine whether or not the product can be used.

The above shows selection procedures for general vacuum pads; thus, they will not be applicable for all pads. Customers are required to conduct a test on their own and to select applicable suction conditions and pads based on the test results.

### ● Points for Selecting Vacuum Pads

#### A. Shear Force and Moment Applied to Vacuum Pad

- a) Vacuum pads are susceptible to shear force (parallel force with adsorption surface) and moment.
- b) Minimize the moment applied to the vacuum pad with the position of the workpiece center of gravity in mind.
- c) The acceleration rate of the movement must be as small as possible, and make sure to take into consideration the wind pressure and impact. If measures to slow down the acceleration rate are introduced, safety to prevent the workpiece from dropping will improve.
- d) Avoid lifting the workpiece by adsorbing the vertical side with a vacuum pad (vertical lifting).
  - When it is unavoidable, a sufficient safety factor must be secured.

ZP3

ZP3E

ZP2

ZP2V

ZP

ZPT  
ZPR

XT661

# Model Selection

## Lifting Force, Moment, Horizontal Force

(Refer to Fig. 1) To lift a workpiece vertically, make sure to take into consideration the acceleration rate, wind pressure, impact, etc., in addition to the mass of the workpiece.

(Refer to Fig. 2) Because the pads are susceptible to moments, mount the pad so as not to allow the workpiece to create a moment.

(Refer to Fig. 3) When a workpiece that is suspended horizontally is moved laterally, the workpiece could shift depending on the extent of the acceleration rate or the size of the friction coefficient between the pad and the workpiece. Therefore, the acceleration rate of the lateral movement must be minimized.

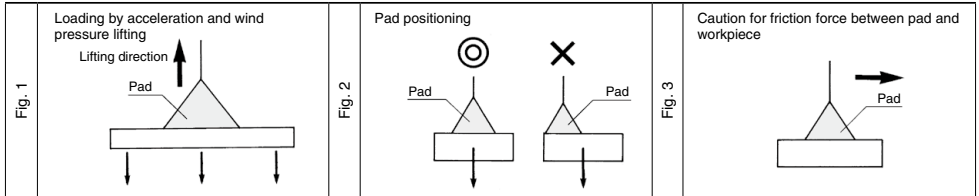

## Balance of Pad and Workpiece

1) Make sure that the pad's adsorption area is not larger than the surface of the workpiece to prevent vacuum leakage and unstable picking.

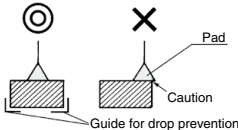

2) If multiple pads are used for transferring a flat object with a large surface area, properly allocate the pads to maintain balance. Also, make sure that the pads are aligned properly to prevent them from becoming disengaged along the edges.

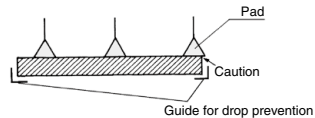

Provide an auxiliary device (example: a guide for preventing the workpieces from dropping) as necessary.

\* Mount the guide for drop prevention so that no load is applied to the workpiece (it does not push the workpiece up). If a load is applied, it is applied to the pad when the guide for drop prevention is removed. This may drop the workpiece.

3) Consider that the load may increase at a certain place due to the suction balance.

## Formula examples with beams (Reference)

Load/Shape conditions			
Formula (Reactive force: R, Total load: W)	$RA=RB=P/2$ $W=P$	$RA=Pb/L$ $RB=Pa/L$ $W=P$	$RA=RC=5Pb/16$ $RB=11P/8$

## Mounting Position

The basic mounting method is a horizontal lift.

Do not perform a suction when tilted, vertical suction, or holding suction (the pad receives the load of the workpiece). If the unit must be installed in such a manner, be certain to guarantee guide and absolute safety.

The vacuum pad is designed for workpiece transfer while suctioned from above. When the workpiece is suctioned from below or it is held with the pad after being positioned by other components, perform a suction test to determine whether or not the transfer method is applicable.

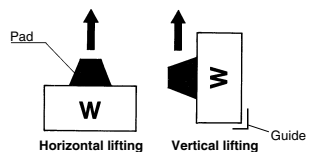

## B. Theoretical Lifting Force

- The theoretical lifting force is determined by vacuum pressure and contact area of the vacuum pad.
- Since the theoretical lifting force is the value measured at the static state, the safety factor responding to the actual operating conditions must be estimated in the actual operation.
- It is not necessarily true that higher vacuum pressure is better. Extremely high vacuum pressure may cause problems.
  - If the vacuum pressure is higher than necessary, an increase in the friction of the pad, generation of cracks, sticking of the pad and workpiece, and sticking of the pad (bellows pad) will occur easily, possibly shortening the life of the pad.
  - Doubling the vacuum pressure makes the theoretical lifting force double, while doubling the pad diameter makes the theoretical lifting force quadruple.
  - When the vacuum pressure (set pressure) is high, it makes not only response time longer, but also the necessary energy to generate a vacuum larger.

**Example) Theoretical lifting force = Pressure x Area** → 2 times

Pad diameter	Area [cm <sup>2</sup> ]	Vacuum pressure [-40 kPa]	Vacuum pressure [-80 kPa]
∅6	0.28	Theoretical lifting force 1.1 N	Theoretical lifting force 2.2 N
∅16	2.01	Theoretical lifting force 8.0 N	Theoretical lifting force 16.1 N

↓ 4 times

### Lifting Force and Vacuum Pad Diameter

- Set the vacuum pressure below the pressure that has been stabilized after adsorption.  
However, when a workpiece is permeable or has a rough surface, note that the vacuum pressure drops since the workpiece takes air in. In this case, it is necessary to perform a suction test to check the vacuum pressure reached during suction.
- The vacuum pressure when using an ejector is approximately -40 to -60 kPa as a guide.

The theoretical lifting force of a pad can be found by calculation or from the theoretical lifting force table.

#### Calculation

$$W = P \times S \times 0.1 \times \frac{1}{t}$$

**W** : Lifting force [N]  
**P** : Vacuum pressure [kPa]  
**S** : Pad area [cm<sup>2</sup>]  
**t** : Safety factor    Horizontal lifting: 4 or more  
                                  Vertical lifting: 8 or more

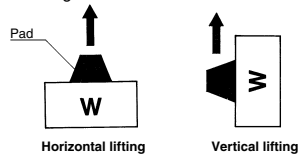

(This type of application should basically be avoided.)

#### Theoretical Lifting Force

The theoretical lifting force (not including the safety factor) is found from the pad diameter and vacuum pressure. The required lifting force is then found by dividing the theoretical lifting force by the safety factor t.

$$\text{Lifting force} = \text{Theoretical lifting force} \div t$$

#### Theoretical Lifting Force (Theoretical lifting force = P x S x 0.1) [N]

Pad diameter [mm]	∅32	∅40	∅50	∅63	∅80	∅100	∅125
S: Pad area [cm <sup>2</sup> ]	8.04	12.56	19.63	31.16	50.24	78.50	122.66
Vacuum pressure [kPa]	-85	68.3	107	167	265	427	667
	-80	64.3	100	157	249	402	628
	-75	60.3	94.2	147	234	377	589
	-70	56.3	87.9	137	218	352	550
	-65	52.2	81.6	128	203	327	510
	-60	48.2	75.4	118	187	301	471
	-55	44.2	69.1	108	171	276	432
	-50	40.2	62.8	98.1	156	251	393
	-45	36.2	56.5	88.3	140	226	353
	-40	32.2	50.2	78.5	125	201	314

ZP3

ZP3E

ZP2

ZP2V

ZP

ZPT  
ZPR

XT661





# Model Selection

## ● Vacuum Pad Type

- Flat type with groove and bellows type with groove are available in the ZP3E series. Select the optimal form in accordance with the workpiece and operating environment.

### Pad Type

Pad form	Application
Flat type with groove 	For adsorption of general workpieces. To be used when adsorption surface of the workpiece is flat and not deformed.
Bellows type with groove 	To be used when adsorption surface of the workpiece is slanted.

\* The bellows of the bellows type pad (including groove) may become stuck due to the operating conditions (flat board, high vacuum pressure, suction time (vacuum holding), etc.). If so, consider using a flat type pad. Select the pad type after evaluating them sufficiently at the customer's site.

## ● Vacuum Pad Material

- It is necessary to determine vacuum pad materials carefully taking into account the workpiece shape, adaptability in the operating environment, effect after being adsorbed, electrical conductivity, etc.

## ● Rubber Material and Properties

General name	NBR (Nitrile rubber)	Silicone rubber	Urethane rubber	FKM (Fluoro rubber)	
Main features	Good oil resistance, abrasion resistance, and aging resistance	Excellent heat resistance, and cold resistance	Excellent mechanical strength	Best heat resistance, and chemical resistance	
Pure gum property (specific gravity)	1.00-1.20	0.95-0.98	1.00-1.30	1.80-1.82	
Physical properties of blended gum	Impact resilience	○	◎	△	
	Abrasion resistance	◎	× to △	◎	
	Tear resistance	○	× to △	◎	
	Flex crack resistance	○	× to ○	◎	
	Maximum operation temperature °C	120	200	60	250
	Minimum operation temperature °C	0	-30	0	0
	Volume resistivity [Ωcm]	—	—	—	—
	Heat aging	○	◎	△	◎
	Weather resistance	○	◎	◎	◎
	Ozone resistance	△	◎	◎	◎
Chemical resistance	Gas permeability resistance	○	× to △	× to △	
	Gasoline/Gas oil	◎	× to △	◎	
	Benzene/Toluene	× to △	×	× to △	
	Alcohol	◎	◎	△	
	Ether	× to △	× to △	×	
	Ketone (MEK)	×	○	×	
	Ethyl acetate	× to △	△	× to △	
Alkaline resistance	Water	◎	○	△	
	Organic acid	× to △	○	×	
	Organic acid of high concentration	△ to ○	△	×	
	Organic acid of low concentration	○	○	△	
	Strong alkali	○	◎	×	
	Weak alkali	○	◎	×	

◎ = Excellent --- Not affected at all, or almost no effect    ○ = Good --- Affected a little, but adequate resistance depending on conditions

△ = Better not to use if possible



× = Unsuitable for usage. Severely affected.

\* Properties, chemical resistance, and other values are not guaranteed.

These values depend on the operating environment, so they cannot be guaranteed by SMC. Thorough research and confirmation are necessary before usage.

## ● Color and Identification

General name	NBR (Nitrile rubber)	Silicone rubber	Urethane rubber	FKM (Fluoro rubber)	Mark-free NBR
Color of rubber	Black	White	Brown	Black	Black
Identification (Symbol)	—	—	—	F	—
Rubber hardness (±5°)	A55	A50	A50	A60	A60

Pad type	Material of the adsorption part (Part in contact with the workpiece)	Adsorption mark *1			Static friction ratio *5
		Condition *2 (Initial value)		Operating temperature range [°C]	
		Visual checking	Vapor method *3		
<b>Mark-free Pad Series</b>  <b>Mark-free NBR pad</b> 	Mark-free NBR (Specially treated *4)	○	○	5 to 40	0.15 to 0.2
<b>Standard</b> <b>ZP series (Standard material)</b> 	NBR FKM Conductive NBR  Silicone rubber Urethane rubber	×  ○	×  ×	—	—

Adsorption mark characteristics [○]: Little or no influence ○: Can be used depending on the conditions. ×: Not suitable

For NBR, FKM, and conductive rubber, black powder (rubber materials) may adhere to the the workpiece when it is adsorbed or when horizontal slippage occurs.

\* The above table is for reference when selecting the pad.

Values and evaluation are reference data only. Preparatory testing under actual operating conditions is recommended.

- \*1 **Adsorption mark** ——— Indicates the transfer of rubber constituents from the pad.
- \*2 **Condition** ——— Visual evaluation of the adsorption mark
- \*3 **Vapor method** ——— Method of applying vapor to the workpiece to visually check for adsorption marks
- \*4 **Specially treated** ——— NBR is specially treated to modify and reduce the transfer of rubber constituents.
- \*5 **Static friction ratio** ——— Static friction ratio when the workpiece (glass) is adsorbed by the pad. (NBR = 1 as a benchmark)

### Cleaning method [Mark-free NBR pad]

- Always clean the product before operation and when carrying out regular maintenance.
- 1) Hold the part other than the adsorption surface.
  - \* Non particle-generating vinyl gloves are recommended.
- 2) Soak a non particle-generating cloth in 2-propanol (isopropyl alcohol) (purity > 99.5%).
  - \* Please use the solution recommended above.
- 3) Wipe the adsorption surface (pad/resin attachment) and the part that comes into contact with the workpiece.
- 4) Dry them with clean air blow. (Or, wipe again with a dry non particle-generating cloth.)

Fine cracks may be generated on the mark-free NBR pad. However, it does not affect product operation.

### Mark-free Pad Series [Mark-free NBR]

- Although the adsorption marks (transfer of rubber component to workpieces) of this product are minimized compared with current rubber pads, confirm if the adsorption marks have any effect when used in the actual system before use.
- 1) High vacuum pressure leaks from the lip may occur in the mark-free pad series due to the manufacturing method compared with common rubber pads.
- 2) Note that this product cannot be used to hold a vacuum.
- 3) Secure as high a flow rate as possible to suppress the pressure effect caused by leakage to a minimum.
- 4) Be sure to wash the portion of the pad that contacts the workpiece before use, or during periodic maintenance. If the pad is not washed correctly, deposits and solvents, etc. from the washing may remain as an adsorption mark.
- 5) When adsorbing workpieces with few impurities (high cleanliness), if "Mark-free NBR" is used, the edge of the pad may wear out early. Please consider using the ZP2 series "Stuck fluororesin pad" or "Resin attachment."

ZP3

ZP3E

ZP2

ZP2V

ZP

ZPT

ZPR

XT661

# Model Selection

## Pad Displacement to Vacuum Pressure (Flat Type with Groove)

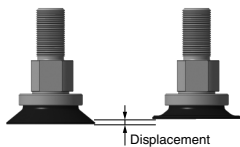

The data shown below are only for reference and are not guaranteed. These values depend on the operating environment, workpiece mass and transfer method. Therefore, thorough research and confirmation are necessary before use.

NBR (N): ——— Silicone rubber (S): ····· Urethane rubber (U): - - - - FKM (F): - · - · - Mark-free NBR (CL): - · - · -

**ZP3E-32UM** □

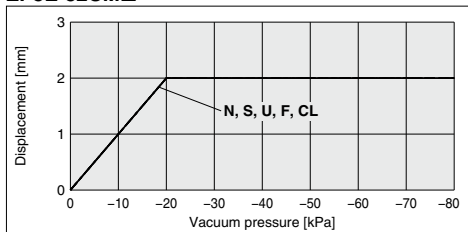

**ZP3E-80UM** □

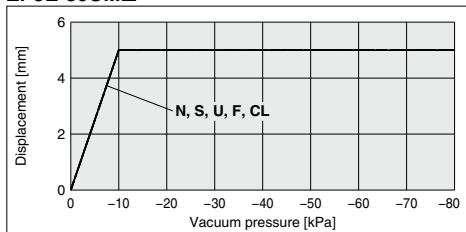

**ZP3E-40UM** □

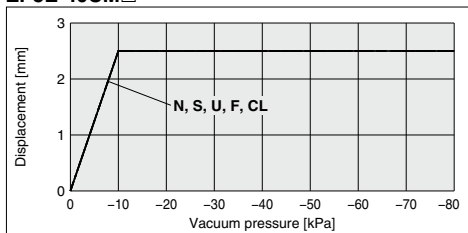

**ZP3E-100UM** □

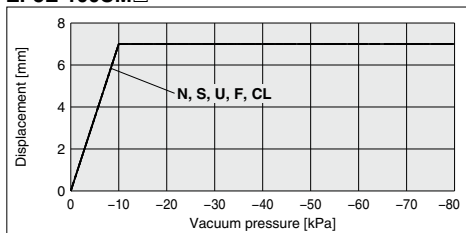

**ZP3E-50UM** □

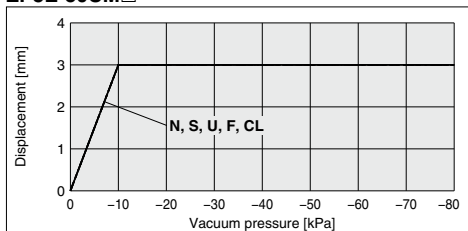

**ZP3E-125UM** □

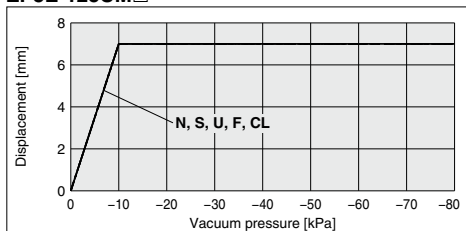

**ZP3E-63UM** □

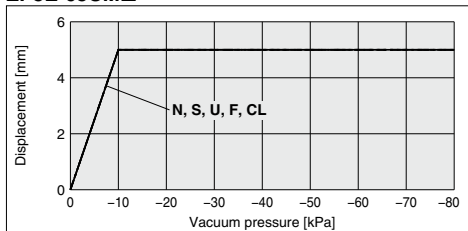

## Pad Displacement to Vacuum Pressure (Bellows Type with Groove)

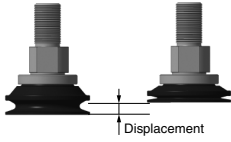

The data shown below are only for reference and are not guaranteed. These values depend on the operating environment, workpiece mass and transfer method. Therefore, thorough research and confirmation are necessary before use.

NBR (N): — Silicone rubber (S): ····· Urethane rubber (U): - - - - FKM (F): - · - · - Mark-free NBR (CL): - - - - -

**ZP3E-32BM** □

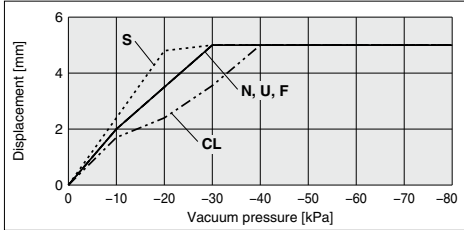

**ZP3E-80BM** □

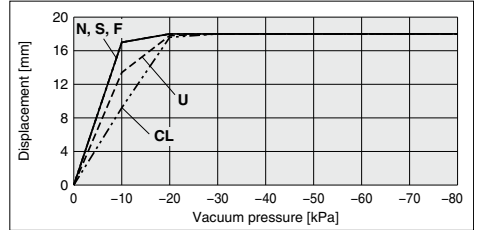

**ZP3E-40BM** □

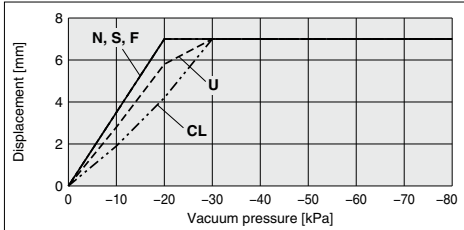

**ZP3E-100BM** □

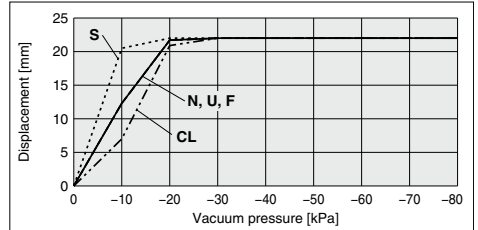

**ZP3E-50BM** □

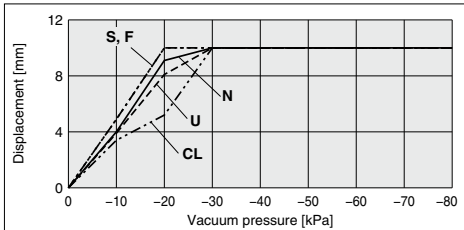

**ZP3E-125BM** □

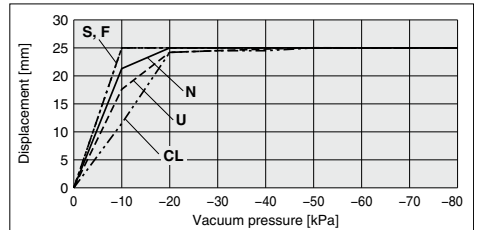

**ZP3E-63BM** □

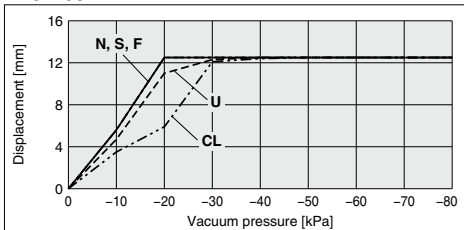

ZP3

ZP3E

ZP2

ZP2V

ZP

ZPT

ZPR

XT661

# Model Selection

## ● Buffer Attachment

- Choose buffer type when the workpieces are of varying heights, the workpieces are fragile, or you need to reduce the impact to the pad. If rotation needs to be limited, use non-rotating buffer.

### Unsteady Distance between Pad and Workpiece

When the workpieces are of varying heights, use the buffer type pad with built-in spring. The spring creates a cushion effect between the pad and the workpieces. If rotation needs to be limited further, use non-rotating buffer type.

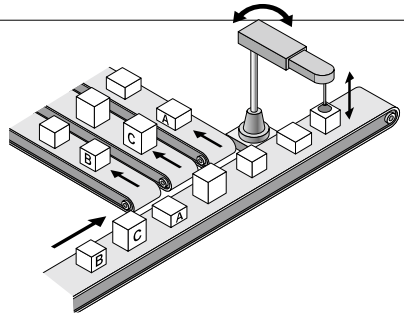
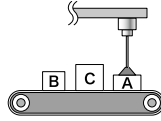

## ● Notes for Attachment

The buffer is manufactured for the purpose of protecting the pad from impact when the pad is applied to a workpiece. An eccentric load applied to the buffer caused by piping (tubing) or the position of the attachment, or an improper tightening torque used when the buffer is attached may lead to poor sliding or a shortened product life. Also, minimize the load in the lateral direction.

## ● Use the buffer within the stroke.

## ● Pad Selection by Workpiece Type

- Carefully select a pad for the following workpieces.

### 1. Porous Workpiece

To pick a permeable workpiece such as paper, select a pad with a small diameter that is sufficient to lift the workpiece. Because a large amount of air leakage could reduce the pad's suction force, it may be necessary to increase the capacity of an ejector or vacuum pump or enlarge the conductance area of the piping passage.

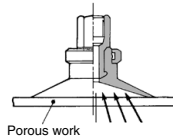

## ● Tube Piping Reference

Prevent eccentric loads caused by piping (tubing) from being applied to the buffer. Route the tube piping with some degree of freedom, and ensure that it extends in the direction of the fitting. Also, make adjustments as required as the long piping, piping bundles, piping material, etc., may become a load.

### 2. Flat Plate Workpiece

When a workpiece with a large surface area such as sheet glass or PCB is suspended, the workpiece could move in a wavelike motion if a large force is applied by wind pressure or by an impact. Therefore, it is necessary to ensure the proper allocation and size of pads.

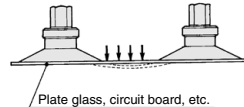

### 3. Soft Workpiece

If a soft workpiece such as vinyl, paper, or thin sheet is picked up, the vacuum pressure could cause the workpiece to deform or wrinkle. In such a case, it will be necessary to use a small pad or a ribbed pad and reduce the vacuum pressure.

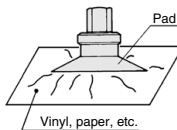

### 4. Impact to Pad



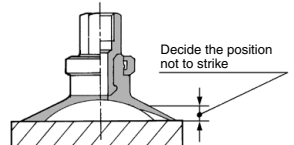

When pushing a pad to a workpiece, make sure not to apply an impact or a large force which would lead to premature deformation, cracking, or wearing of the pad. The pad should be pushed against the workpiece to the extent that its skirt portion deforms or that its ribbed portion comes into slight contact with the workpiece. Especially, when using a smaller diameter pad, make sure to locate it correctly.



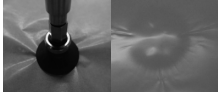

## 5. Adsorption Mark

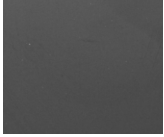
The main adsorption marks are as follows:

	Before suction	After suction	Countermeasure
<ul style="list-style-type: none"> <li>● Mark due to deformed (lined) workpiece</li> </ul>			1) Reduce the vacuum pressure. If lifting force is inadequate, increase the number of pads. 2) Select a pad with a smaller center area.
Suction conditions		Workpiece: Vinyl Vacuum pad: ZP20CS Vacuum pressure: -40 kPa	
<ul style="list-style-type: none"> <li>● Mark due to components contained in the rubber pad (material) moving to the workpiece.</li> </ul>			Use the following products. 1) Mark-free NBR pad 2) ZP2 series <ul style="list-style-type: none"> <li>• Stuck fluororesin pad</li> <li>• Resin attachment</li> </ul>
Suction conditions		Workpiece: Glass Vacuum pad: ZP20CS Vacuum pressure: -40 kPa	
<ul style="list-style-type: none"> <li>● A mark which remains on the rough surface of the workpiece due to wear-out of the rubber (pad material).</li> </ul>			Use the following products. 1) ZP2 series <ul style="list-style-type: none"> <li>• Stuck fluororesin pad</li> <li>• Resin attachment</li> </ul>
Suction conditions		Workpiece: Resin plate (Surface roughness 2.5 μ) Vacuum pad: ZP20CS Vacuum pressure: -80 kPa	

## Vacuum Pad Durability

- Need to be careful of the vacuum pad (rubber) deterioration.
- When the vacuum pad is used continuously, the following problems may occur.
  - 1) Wear-out of the adsorption surface.
    - Shrinkage of the pad dimensions, sticking of the part where the rubber materials come into contact with each other (bellows pad)
    - 2) Weakening of the rubber parts (skirt of the adsorption surface, bending parts, etc.)
- \* It may occur at an early stage depending on the operating conditions (high vacuum pressure, suction time [vacuum holding], etc.).
- Decide when to replace the pads, referring to the signs of deterioration, such as changes in the appearance due to wear, reduction in the vacuum pressure or delay in the transport cycle time.

ZP3

ZP3E

ZP2

ZP2V

ZP

ZPT

ZPR

XT661

# Model Selection

## 3 Selection of Vacuum Ejector and Vacuum Switching Valve

### ● Calculating Vacuum Ejector and Switching Valve Size with the Formula

Average suction flow rate for achieving adsorption response time

$$Q = \frac{V \times 60}{T_1} + Q_L$$

$$T_2 = 3 \times T_1$$

**Q** : Average suction flow rate [L/min (ANR)]

**V** : Piping capacity [L]

**T<sub>1</sub>** : Arrival time to stable **P<sub>v</sub>** 63% after adsorption [sec]

**T<sub>2</sub>** : Arrival time to stable **P<sub>v</sub>** 95% after adsorption [sec]

**Q<sub>L</sub>** : Leakage volume during workpiece adsorption [L/min (ANR)] <sup>(Note 1)</sup>

Max. suction flow rate

$$Q_{max} = (2 \text{ to } 3) \times Q \text{ [L/min (ANR)]}$$

<Selection Procedure>

#### ● Ejector

Select the ejector with the greater maximum suction flow rate from the **Q<sub>max</sub>** indicated above.

#### ● Direct operation valve

$$\text{Conductance } C = \frac{Q_{max}}{55.5} \text{ [dm}^3\text{/(s-bar)]}$$

\* Select a valve (solenoid valve) having a conductance that is greater than that of the conductance **C** formula given above from the related equipment (page 793).

Note 1) **Q<sub>L</sub>**: 0 when no leakage occurs during adsorbing a workpiece.

If there is leakage during adsorbing a workpiece, find the leakage volume based on "4. Leakage Volume during Workpiece Adsorption."

Note 2) Tube piping capacity can be found in "8. Data: Piping Capacity by Tube I.D. (Selection Graph (2))."

## 4 Leakage Volume during Workpiece Adsorption

Air could be drawn in depending on the type of workpiece. As a result, the vacuum pressure in the pad becomes reduced and the amount of vacuum that is necessary for adsorption cannot be attained.

When this type of workpiece must be handled, it is necessary to select the proper size of the ejector and the vacuum switching valve by taking into consideration the amount of air that could leak through the workpiece.

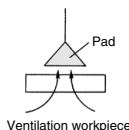

Ventilation workpiece

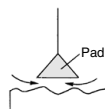

Rough workpiece surface

### ● Leakage Volume from Conductance of Workpiece

$$\text{Leakage volume } Q_L = 55.5 \times C_L$$

**Q<sub>L</sub>**: Leakage volume [L/min (ANR)]

**C<sub>L</sub>**: Conductance between workpiece and pad, and workpiece opening area [dm<sup>3</sup>/(s-bar)]

### ● Leakage Volume from Suction Test

As described in the illustration below, pick up the workpiece with the ejector, using an ejector, pad and a vacuum gauge.

At this time, read vacuum pressure **P<sub>v</sub>**, obtain the suction flow rate from the flow rate characteristics graph for the ejector that is being used, and render this amount as the leakage of the workpiece.

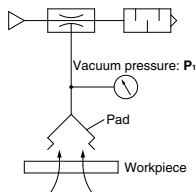

**Exercise:** Using a supply pressure of 0.45 MPa, when the ejector (ZH07□S) picks up a workpiece that leaks air, the vacuum gauge indicated a pressure of -53 kPa. Calculate the leakage volume from the workpiece.

<Selection Procedure>

When obtaining the suction flow rate at a vacuum pressure of -53 kPa from the ZH07DS flow rate characteristics graph, the suction flow rate is 5 L/min (ANR). (A→B→C)

$$\text{Leakage volume} = \text{Suction flow rate } 5 \text{ L/min (ANR)}$$

### ZH07BS, ZH07DS

#### Exhaust Characteristics

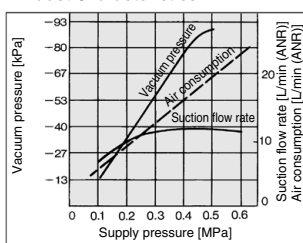

#### Flow Rate Characteristics

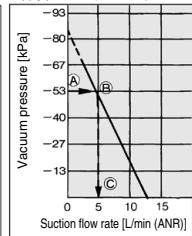

## 5 Adsorption Response Time

When a vacuum pad is used for the adsorption transfer of a workpiece, the approximate adsorption response time can be obtained (the length of time it takes for the pad's internal vacuum pressure to reach the pressure that is required for adsorption after the supply valve (vacuum switching valve) has been operated). An approximate adsorption response time can be obtained through formulas and selection graphs.

### ● Relationship between Vacuum Pressure and Response Time after Supply Valve (Switching Valve) is Operated

The relationship between vacuum pressure and response time after the supply valve (switching valve) is operated as shown below.

**Vacuum System Circuit**

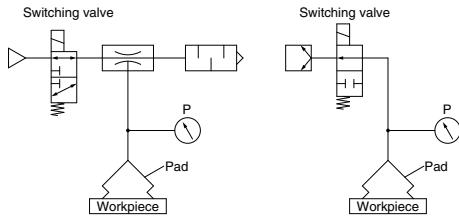

**Vacuum Pressure and Response Time after Supply Valve (Switching Valve) is Operated**

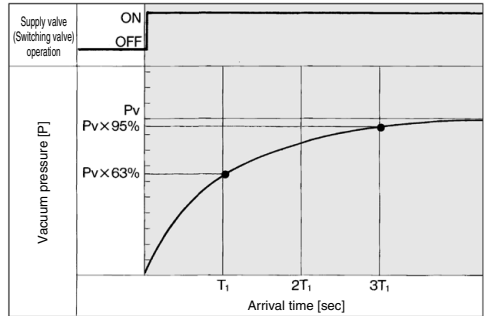

**Pv**: Final vacuum pressure  
**T<sub>1</sub>**: Arrival time to 63% of final vacuum pressure **Pv**  
**T<sub>2</sub>**: Arrival time to 95% of final vacuum pressure **Pv**

### ● Calculating Adsorption Response Time with the Formula

Adsorption response times **T<sub>1</sub>** and **T<sub>2</sub>** can be obtained through the formulas given below.

**Adsorption response time**  $T_1 = \frac{V \times 60}{Q}$

**Adsorption response time**  $T_2 = 3 \times T_1$

**Piping capacity**

$$V = \frac{3.14}{4} D^2 \times L \times \frac{1}{1000} \text{ [L]}$$

**T<sub>1</sub>**: Arrival time to 63% of final vacuum pressure **Pv** [sec]

**T<sub>2</sub>**: Arrival time to 95% of final vacuum pressure **Pv** [sec]

**Q<sub>1</sub>**: Average suction flow rate [L/min (ANR)]

Calculation of average suction flow rate

- Ejector

$$Q_1 = (1/2 \text{ to } 1/3) \times \text{Ejector max. suction flow rate [L/min (ANR)]}$$

- Vacuum pump

$$Q_1 = (1/2 \text{ to } 1/3) \times 55.5 \times \text{Conductance of vacuum pump [dm}^3\text{/(s-bar)]}$$

**D**: Piping diameter [mm]

**L**: Length from ejector and switch valve to pad [m]

**V**: Piping capacity from ejector and switching valve to pad [L]

**Q<sub>2</sub>**: Max. flow from ejector and switching valve to pad by piping system

$$Q_2 = C \times 55.5 \text{ L/min (ANR)}$$

**Q**: Smaller one between the **Q<sub>1</sub>** and **Q<sub>2</sub>** [L/min (ANR)]

**C**: Conductance of piping [dm<sup>3</sup>/(s-bar)]

For the conductance, the equivalent conductance can be found in "8. Data: Conductance by Tube I.D. (Selection Graph (3))."

ZP3

ZP3E

ZP2

ZP2V

ZP

ZPT

ZPR

XT661

# Model Selection

## ● Adsorption Response Time from the Selection Graph

### 1. Tube Piping Capacity

Piping capacity from the ejector and switching valve at vacuum pump to the pad can be found in "8. Data: Piping Capacity by Tube I.D. (Selection Graph (2))."

### 2. Obtain the adsorption response times.

By operating the supply valve (switching valve) that controls the ejector (vacuum pump), the adsorption response times  $T_1$  and  $T_2$  that elapsed before the prescribed vacuum pressure is reached can be obtained from the Selection Graph (1).

Selection Graph (1) Adsorption Response Time

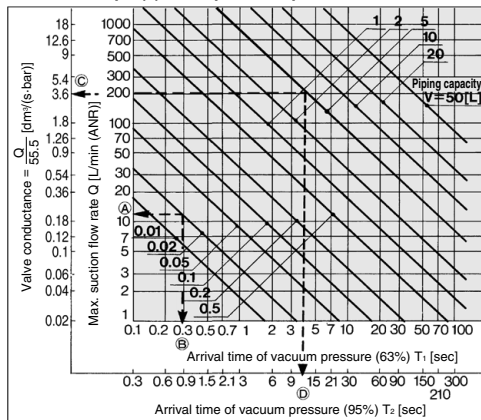

\* Conversely, the size of the ejector or the size of the switching valve of the vacuum pump system can be obtained from the adsorption response time.

### How to read the graph

Example 1: For obtaining the adsorption response time until the pressure in the piping system with a piping capacity of 0.02 L is discharged to 63% ( $T_1$ ) of the final vacuum pressure through the use of the vacuum ejector ZH07□S with a maximum suction flow rate of 12 L/min (ANR).

#### <Selection Procedure>

From the point at which the vacuum ejector's maximum vacuum suction flow rate of 12 L/min (ANR) and the piping capacity of 0.02 L intersect, the adsorption response time  $T_1$  that elapses until 63% of the maximum vacuum pressure is reached can be obtained. (Sequence in Selection Graph (1), (A)→(B))  $T_1 = 0.3$  seconds.

Example 2: For obtaining the discharge response time until the internal pressure in the 5 L tank is discharged to 95% ( $T_2$ ) of the final vacuum pressure through the use of a valve with a conductance of 3.6 dm³/(s·bar).

#### <Selection Procedure>

From the point at which the valve's conductance of 3.6 dm³/(s·bar) and the piping capacity of 5 L intersect, the discharge response time ( $T_2$ ) that elapses until 95% of the final vacuum pressure is reached can be obtained. (Sequence in Selection Graph (1), (C)→(D))  $T_2 \approx 12$  seconds.

## 6 Precautions on Vacuum Equipment Selection and SMC's Proposal

### ● Safety Measures

- Make sure to provide a safe design for a vacuum pressure drop due to a disruption of power supply, or a lack of supply air. Drop prevention measures must be taken in particular when dropping a workpiece presents some degree of danger.

### ● Precautions on Vacuum Equipment Selection

As a countermeasure for power outages, select a supply valve that is normally open or one that is equipped with a self-holding function.

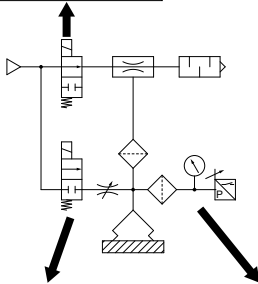

For the release valve, select a 2/3 port valve with a low vacuum specification. Also, use a needle valve to regulate the release flow rate.

- During the adsorption and transfer of a workpiece, verification of the vacuum switch is recommended.
- In addition, visually verify the vacuum gauge when handling a heavy or a hazardous item.
- Install a filter (ZFA, ZFB, ZFC series) before the pressure switch if the ambient air is of low quality.

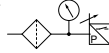

Select a vacuum switching valve that has a conductance that does not reduce the composite conductance consisting of the areas from the pad to the ejector.

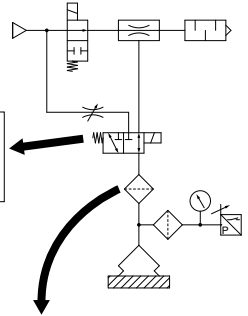

Use a suction filter (ZFA, ZFB, ZFC series) to protect the switching valve and to prevent the ejector from becoming clogged. Also, a suction filter must be used in a dusty environment. If only the unit's filter is used, it will become clogged quickly.

### ● Vacuum Ejector or Pump and Number of Vacuum Pads

Ejector and number of pads		Vacuum pump and number of pads	
Ideally, one pad should be used for each ejector.	When more than one pad is attached to a single ejector, if one of the workpieces becomes detached, the vacuum pressure will drop, causing other workpieces to become detached. Therefore, the countermeasures listed below must be taken. <ul style="list-style-type: none"> <li>• Adjust the needle valve to minimize the pressure fluctuation between adsorption and non-adsorption operations.</li> <li>• Provide a vacuum switching valve to each individual pad to minimize the influences on other pads if an adsorption error occurs.</li> </ul>	Ideally, one pad should be used for each line.	When more than one pad is attached to a single vacuum line, take the countermeasures listed below. <ul style="list-style-type: none"> <li>• Adjust the needle valve to minimize the pressure fluctuation between adsorption and non-adsorption operation.</li> <li>• Include a tank and a vacuum pressure reduction valve (vacuum pressure regulator valve) to stabilize the source pressure.</li> <li>• Provide a vacuum switching valve to each individual pad to minimize the influences on other pads if an adsorption error occurs.</li> </ul>

ZP3

ZP3E

ZP2

ZP2V

ZP

ZPT

ZPR

XT661



# Model Selection

## ● Vacuum Ejector Selection and Handling Precautions

### Ejector Selection

There are 2 types of ejector flow rate characteristics: the high vacuum type (S type) and the high flow type (L type). During the selection, pay particular attention to the vacuum pressure when adsorbing workpieces that leak.

#### High Vacuum Type Flow Rate Characteristics/ ZH13□S

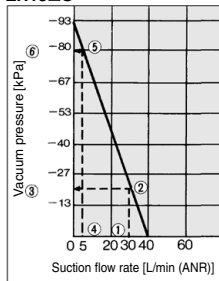

#### High Flow Type Flow Rate Characteristics/ ZH13□L

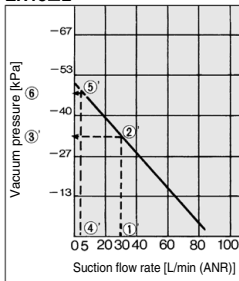

The vacuum pressure varies in accordance with the leakage volumes indicated in the above diagrams.

If the leakage volume is 30 L/min (ANR), the vacuum pressure of the S type is  $-20 \text{ kPa}$  (①)  $\rightarrow$  (②)  $\rightarrow$  (③), and for the L type it is  $-33 \text{ kPa}$  (①')  $\rightarrow$  (②')  $\rightarrow$  (③'). If the leakage volume is 5 L/min (ANR), the vacuum pressure of the S type is  $-80 \text{ kPa}$  (④)  $\rightarrow$  (⑤)  $\rightarrow$  (⑥), and for the L type it is  $-47 \text{ kPa}$  (④')  $\rightarrow$  (⑤')  $\rightarrow$  (⑥'). Thus, if the leakage volume is 30 L/min (ANR) the L type can attain a higher vacuum pressure, and if the leakage volume is 5 L/min (ANR) the S type can attain a higher vacuum pressure.

Thus, during the selection process, make sure to take the flow rate characteristics of the high vacuum type (S type) and the high flow type (L type) into consideration in order to select the type that is optimal for your application.

- If the vacuum ejector makes an intermittent noise (abnormal noise) from exhaust at a certain supply pressure, the vacuum pressure will not be stable. It will not be any problem if the vacuum ejector is used under this condition. However, if the noise is disturbing or might affect the operation of the vacuum pressure switch, lower or raise supply pressure a little at a time, and use in an air pressure range that does not produce the intermittent noise.

## ● Supply Pressure of Vacuum Ejector

- It is recommended to use the vacuum ejector at the standard supply pressure. The maximum vacuum pressure and suction flow rate can be obtained when the vacuum ejector is used at the standard supply pressure, and as a result, adsorption response time also improves. From the viewpoint of energy-saving, it is the most effective to use the ejector at the standard supply pressure. Since using it at an excessive supply pressure may cause the ejector performance to lower, it is recommended to use at the standard supply pressure.

## ● Timing for Vacuum Generation and Suction Verification

### A. Timing for Vacuum Generation

The time for opening/closing the valve will be counted if a vacuum is generated after the adsorption pad descends to adsorb a workpiece. Also, there is a timing delay risk for the generating vacuum since the operational pattern for the verification switch, which is used for detecting the descending vacuum pad, is not even.

To solve this issue, we recommend that vacuum be generated in advance, before the vacuum pad begins to descend to the workpiece. Adopt this method after confirming that there will be no misalignment resulting from the workpiece's light mass.

### B. Suction Verification

When lifting the vacuum pad after adsorbing a workpiece, confirm that there is a suction verification signal from the vacuum pressure switch, before the vacuum pad is lifted. If the vacuum pad is lifted, based on the timing of a timer etc., there is a risk that the workpiece may be left behind.

In general adsorption transfer, the time for adsorbing a workpiece is slightly different since the position of the vacuum pad and the workpiece are different after every operation. Therefore, program a sequence in which the suction completion is verified by a vacuum pressure switch etc., before moving to the next operation.

### Ejector Nozzle Diameter Selection

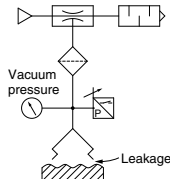

If a considerable amount of leakage occurs between the workpiece and the pad, resulting in incomplete adsorption, or to shorten the adsorption and transfer time, select an ejector nozzle with a larger diameter from the ZH, ZR, or ZL series.

### Manifold Use

#### Individual exhaust

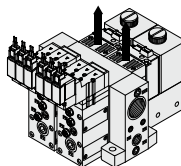

#### Centralized exhaust

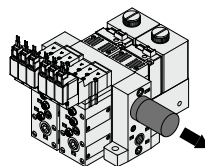

If there are a large number of ejectors that are linked on a manifold and operate simultaneously, use the built-in silencer type or the port exhaust type.

If there are a large number of ejectors that are linked on a manifold, which exhaust collectively, install a silencer at both ends. If the exhaust must be discharged outdoors through piping, make the diameter of the piping larger to control its back pressure to 5 kPa or less so that the back pressure will not affect the operation of the ejectors.

## C. Set Pressure for Vacuum Pressure Switch

Set the optimum value after calculating the required vacuum pressure for lifting a workpiece.

If a higher pressure than required is set, there is a possibility of being unable to confirm the suction even though the workpiece is adsorbed. This will result in a suction error.

When setting vacuum pressure switch set values, you should set using a lower pressure, with which a workpiece can be adsorbed, only after considering the acceleration or vibration when a workpiece is transferred. The set value of the vacuum pressure switch shortens the time to lift a workpiece. Since the switch detects whether the workpiece is lifted or not, the pressure must be set high enough to detect it.

### Vacuum Pressure Switch (ZSE series), Flow sensor (PFMV series), Vacuum Pressure Gauge (GZ series)

When adsorbing and transferring a workpiece, verify at the vacuum pressure switch as much as possible (In addition, visually verify the vacuum gauge, especially when handling a heavy or a hazardous item.).

#### Approx. $\phi 1$ adsorption nozzle

The difference in pressure between ON and OFF becomes small depending on the capacity of the ejector and vacuum pump.

In such a case, it is necessary to use the **digital pressure switch ZSE10 or ZSE30A with a fine smallest settable increment or a flow switch for flow rate detection.**

Note) • A vacuum generator with a large suction capacity will not be detected properly, so an ejector with an appropriate capacity must be selected.

• Since the hysteresis is small, vacuum pressure must be stabilized.

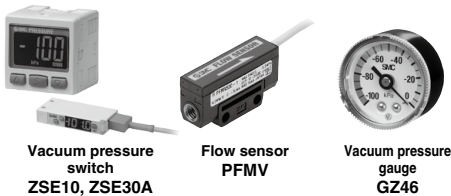

Vacuum pressure switch  
ZSE10, ZSE30A

Flow sensor  
PFMV

Vacuum pressure gauge  
GZ46

Refer to the Best Pneumatics No. 8 for details.

### Timing Chart Example

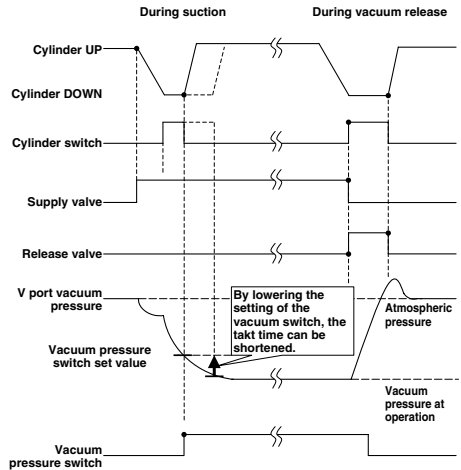

## ● Dust Handling of Vacuum Equipment

- When the vacuum equipment is used, not only the workpiece, but also dust in the surrounding environment is taken in the vacuum equipment. Preventing the intrusion of dust is required more than for any other pneumatic equipment. Some of SMC's vacuum equipment comes with a filter, but when there is a large amount of dust, an additional filter must be installed.
- When vaporized materials such as oil or adhesive are sucked into the equipment, they accumulate inside, which may cause problems.
- It is important to prevent dust from entering the vacuum equipment as much as possible.
  - (1) Make sure to keep the working environment and surrounding area of the workpiece clean so that dust will not be sucked in the equipment.
  - (2) Check the amount and types of dust before using the equipment and install a filter etc., in the piping when necessary.
  - (3) Conduct a test and make sure that operating conditions are cleared before using the equipment.
  - (4) Perform filter maintenance depending on the amount of dirt.
  - (5) Filter clogging generates a pressure difference between the adsorption and ejector parts. This requires attention, since clogging can prevent proper adsorption from being achieved.

### Air Suction Filter (ZFA, ZFB, ZFC series)

- To protect the switching valve and the ejector from becoming clogged, a suction filter in the vacuum circuit is recommended.
- When using an ejector in a dusty environment, the unit's filter will become clogged quickly, so it is recommended that the ZFA, ZFB or ZFC series be used concurrently.

### Vacuum Line Equipment Selection

Determine the volume of the suction filter and the conductance of the switching valve in accordance with the maximum suction flow rate of the ejector and the vacuum pump. Make sure that the conductance is greater than the value that has been obtained through the formula given below. (If the devices are connected in series in the vacuum line, their conductances must be combined.)

$$C = \frac{Q_{\max}}{55.5} \quad C: \text{Conductance [dm}^3/(\text{s}\cdot\text{bar})]$$

$Q_{\max}$ : Max. suction flow rate [L/min (ANR)]

ZP3

ZP3E

ZP2

ZP2V

ZP

ZPT

ZPR

XT661

# Model Selection

## 7 Vacuum Equipment Selection Example

### ● Transfer of Semiconductor Chips

#### Selection conditions:

- (1) Workpiece: Semiconductor chips  
Dimensions: 8 mm x 8 mm x 1 mm, Mass: 1 g
- (2) Vacuum piping length: 1 m
- (3) Adsorption response time: 300 msec or less

#### 1. Vacuum Pad Selection

- (1) Based on the workpiece size, the pad diameter is 4 mm (1 pc.).
- (2) Using the formula on page 385, check the lifting force.

$$\begin{aligned}W &= P \times S \times 0.1 \times 1/t \\0.0098 &= P \times 0.13 \times 0.1 \times 1/4 \\P &= 3.0 \text{ kPa}\end{aligned}$$

$$\begin{cases}W = 1 \text{ g} = 0.0098 \text{ N} \\S = \pi/4 \times (0.4)^2 = 0.13 \text{ cm}^2 \\t = 4 \text{ (Horizontal lifting)}\end{cases}$$

According to the calculation, -3.0 kPa or more of vacuum pressure can adsorb the workpiece.

- (3) Based on the workpiece shape and type, select:  
Pad type: Flat type with groove  
Pad material: Silicone rubber
- (4) According to the results above, select a vacuum pad part number ZP3-04UMS.

#### 2. Vacuum Ejector Selection

- (1) Find the vacuum piping capacity.  
Assuming that the tube I.D. is 2 mm, the piping capacity is as follows:  
$$V = \pi/4 \times D^2 \times L \times 1/1000 = \pi/4 \times 2^2 \times 1 \times 1/1000 = 0.0031 \text{ L}$$
- (2) Assuming that leakage ( $Q_L$ ) during adsorption is 0, find the average suction flow rate to meet the adsorption response time using the formula on page 392.

$$Q = (V \times 60) / T_1 + Q_L = (0.0031 \times 60) / 0.3 + 0 = 0.62 \text{ L}$$

From the formula on page 392, the maximum suction flow rate  $Q_{max}$  is

$$\begin{aligned}Q_{max} &= (2 \text{ to } 3) \times Q = (2 \text{ to } 3) \times 0.62 \\&= 1.24 \text{ to } 1.86 \text{ L/min (ANR)}\end{aligned}$$

According to the maximum suction flow rate of the vacuum ejector, a nozzle with a 0.5 diameter can be used. If the vacuum ejector ZX series is used, representative model ZX105□ can be selected. (Based on the operating conditions, specify the complete part number for the vacuum ejector used.)

#### 3. Adsorption Response Time Confirmation

Confirm the adsorption response time based on the characteristics of the vacuum ejector selected.

- (1) The maximum suction flow rate of the vacuum ejector ZX105□ is 5 L/min (ANR).  
From the formula on page 393, the average suction flow rate  $Q_1$  is as follows:

$$\begin{aligned}Q_1 &= (1/2 \text{ to } 1/3) \times \text{Ejector max. suction flow rate} \\&= (1/2 \text{ to } 1/3) \times 5 = 2.5 \text{ to } 1.7 \text{ L/min (ANR)}\end{aligned}$$

- (2) Next, find the maximum flow rate  $Q_2$  of the piping. The conductance  $C$  is 0.22 from the Selection Graph (3).  
From the formula on page 393, the maximum flow rate is as follows:

$$Q_2 = C \times 55.5 = 0.22 \times 55.5 = 12.2 \text{ L/min (ANR)}$$

- (3) Since  $Q_2$  is smaller than  $Q_1$ ,  $Q = Q_1$ .

Thus, from the formula on page 393, the adsorption response time is as follows:

$$\begin{aligned}T &= (V \times 60) / Q = (0.0031 \times 60) / 1.7 = 0.109 \text{ seconds} \\&= 109 \text{ msec}\end{aligned}$$

It is possible to confirm that the calculation result satisfies the required specification of 300 msec.

## 8 Data

### ● Selection Graph

**Selection Graph (2) Piping Capacity by Tube I.D.**

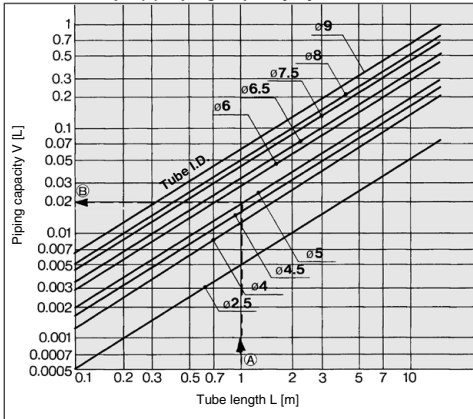

**How to read the graph**

Example: For obtaining the capacity of tube I.D. ø5 and 1 meter length

**<Selection Procedure>**

By extending leftward from the point at which the 1 meter tube length on the horizontal axis intersects the line for a tube I.D. ø5, the piping capacity approximately equivalent to 0.02 L can be obtained on the vertical axis.

**Piping capacity = 0.02 L**

**Selection Graph (3) Conductance by Tube I.D.**

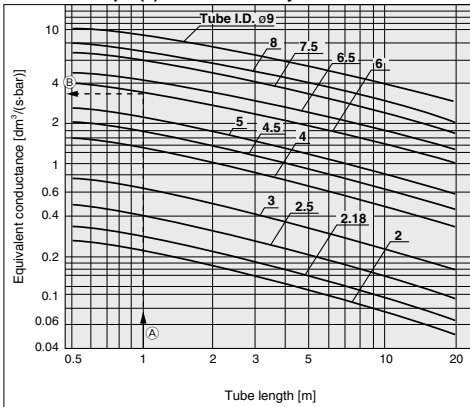

**How to read the graph**

Example: Tube size ø8/ø6 and 1 meter length

**<Selection Procedure>**

By extending leftward from the point at which the 1 meter tube length on the horizontal axis intersects the line for a tube I.D. ø6, the equivalent conductance approximately 3.6 dm³/(s·bar) can be obtained on the vertical axis.

**Equivalent conductance = 3.6 dm³/(s·bar)**

ZP3
ZP3E
ZP2
ZP2V
ZP
ZPT
ZPR
XT661

# Model Selection

## ● Glossary of Terms

Terms	Description
(Max.) suction flow rate	Volume of air taken in by the ejector. The maximum value is the volume of air taken in without having anything connected to the vacuum port.
Maximum vacuum pressure	The maximum value of the vacuum pressure generated by the ejector
Air consumption	The compressed volume of air consumed by the ejector
Standard supply pressure	The optimal supply pressure for operating the ejector
Exhaust characteristics	The relationship between the vacuum pressure and the suction flow rate when the supply pressure to the ejector has been changed.
Flow rate characteristics	The relationship between the vacuum pressure and the suction flow rate with the standard supply pressure supplied to the ejector.
Vacuum pressure switch	Pressure switch for verifying the adsorption of a workpiece
(Air) supply valve	Valve for supplying compressed air to the ejector
(Vacuum) release valve	Valve for supplying positive pressure or air for breaking the vacuum state of the adsorption pad
Flow adjustment valve	Valve for adjusting the volume of air for breaking the vacuum
Pilot pressure	Pressure for operating the ejector valve
External release	The action of breaking the vacuum using externally supplied air instead of using the ejector unit
Vacuum port	Port for generating vacuum
Exhaust port	Port for exhausting air consumed by the ejector, and air taken in from the vacuum port.
Supply port	Port for supplying air to the ejector
Back pressure	Pressure inside the exhaust port
Leakage	The entry of air into the vacuum passage, such as from an area between a workpiece and a pad, or between a fitting and a tube. The vacuum pressure decreases when leakage occurs.
Response time	The time from the application of the rated voltage to the supply valve or release valve, until V port pressure reaches the specified pressure.
Average suction flow rate	The suction flow rate by the ejector or pump for calculating the response speed. It is 1/2 to 1/3 of the maximum suction flow rate.
Conductive pad	A low electrical resistance pad for electrostatic prevention measure
Vacuum pressure	Any pressure below the atmospheric pressure. When the atmospheric pressure is used as a reference, the pressure is represented by $-kPa$ (G), and when the absolute pressure is used as a reference, the pressure is represented by $kPa$ (abs). When referencing a piece of vacuum equipment such as an ejector, the pressure is generally represented by $-kPa$ .
Ejector	A unit for generating vacuum by discharging the compressed air from a nozzle at a high speed, based on the phenomenon in which the pressure is reduced when the air around the nozzle is sucked.
Air suction filter	Vacuum filter provided in the vacuum passage for preventing the dust intrusion into the ejector, vacuum pump, or peripheral equipment

## ● Countermeasures for Vacuum Adsorption System Problems (Troubleshooting)

Condition & Description of improvement	Contributing factor	Countermeasure
Initial adsorption problem (During trial operation)	Adsorption area is small. (Lifting force is lower than the workpiece mass.)	Recheck the relationship between workpiece mass and lifting force. • Use a vacuum pad with a large adsorption area. • Increase the quantity of vacuum pads.
	Vacuum pressure is low. (Leakage from adsorption surface) (Air permeable workpiece)	Eliminate (reduce) leakage from adsorption surface. • Reconsider the shape of a vacuum pad. Check the relationship between suction flow rate and arrival pressure of vacuum ejector. • Use a vacuum ejector with a high suction flow rate. • Increase adsorption area.
	Vacuum pressure is low. (Leakage from vacuum piping)	Repair leakage point.
	Internal volume of vacuum circuit is large.	Check the relationship between internal volume of the vacuum circuit and suction flow rate of the vacuum ejector. • Reduce internal volume of the vacuum circuit. • Use a vacuum ejector with a high suction flow rate.



# Model Selection

Condition & Description of improvement	Contributing factor	Countermeasure
Initial adsorption problem (During trial operation)	Pressure drop of vacuum piping is large.	Reconsider vacuum piping. • Use a shorter or larger tube (with appropriate diameter).
	Inadequate supply pressure of vacuum ejector	Measure supply pressure in vacuum generation state. • Use standard supply pressure. • Reconsider compressed air circuit (line).
	Clogging of nozzle or diffuser (Infiltration of foreign matter during piping)	Remove foreign matter.
	Supply valve (switching valve) is not being activated.	Measure supply voltage at the solenoid valve with a tester. • Reconsider electric circuits, wiring and connectors. • Use in the rated voltage range.
	Workpiece deforms during adsorption.	Since a workpiece is thin, it deforms and leakage occurs. • Use a pad for adsorption of thin objects.
Late vacuum achieving time (Shortening of response time)	Internal volume of vacuum circuit is large.	Check the relationship between internal volume of the vacuum circuit and suction flow rate of the vacuum ejector. • Reduce internal volume of the vacuum circuit. • Use a vacuum ejector with a high suction flow rate.
	Pressure drop of vacuum piping is large.	Reconsider vacuum piping. • Use a shorter or larger tube (with appropriate diameter).
	Using the product as close to the highest vacuum power in the specifications.	Set vacuum pressure to minimum necessary value by optimizing the pad diameter etc. As the vacuum power of an ejector (venturi) rises, the vacuum flow actually lowers. When an ejector is used at its highest possible vacuum value, the vacuum flow will lower. Due to this, the amount of time needed to achieve adsorption is lengthened. One should consider an increase in the diameter of the ejector nozzle or an increase the size of the vacuum pad utilized in order to lower the required vacuum pressure, maximum the vacuum flow, and speed up the adsorption process.
	Setting of vacuum pressure switch is too high.	Set to suitable setting pressure.
Fluctuation in vacuum pressure	Fluctuation in supply pressure	Reconsider compressed air circuit (line). (Addition of a tank etc.)
	Vacuum pressure may fluctuate under certain conditions due to ejector characteristics.	Lower or raise supply pressure a little at a time, and use in a supply pressure range where vacuum pressure does not fluctuate.
Occurrence of abnormal noise (intermittent noise) from exhaust of vacuum ejector	Intermittent noise may occur under certain conditions due to ejector characteristics.	Lower or raise supply pressure a little at a time, and use in a supply pressure range where the intermittent noise does not occur.
Air leakage from vacuum port of manifold type vacuum ejector	Exhaust air from the ejector enters the vacuum port of another ejector that is stopped.	Use a vacuum ejector with a check valve. (Please contact SMC for the part number of an ejector with a check valve.)
Adsorption problem over time (Adsorption is normal during trial operation.)	Clogging of suction filter	Replace filters. Improve installation environment.
	Clogging of sound absorbing material	Replace sound absorbing materials. Add a filter to supply (compressed) air circuit. Install an additional suction filter.
	Clogging of nozzle or diffuser	Remove foreign matter. Add a filter to supply (compressed) air circuit. Install an additional suction filter.
	Vacuum pad (rubber) deterioration, cracking, etc.	Replace vacuum pads. Check the compatibility of vacuum pad material and workpiece.
Workpiece is not released.	Inadequate release flow rate	Open release flow adjustment needle.
	Vacuum pressure is high. Excessive force (adhesiveness of the rubber + vacuum pressure) is applied to the pad (rubber part).	Reduce the vacuum pressure. If inadequate lifting force causes a problem in transferring the workpieces, increase the number of pads.
	Effects due to static electricity	Use a conductive pad.
	Adhesiveness of the rubber increases due to the operating environment or wearing of the pad. • Adhesiveness of the rubber material is high. • Adhesiveness increases due to wearing of the vacuum pad (rubber).	Replace pads. Reconsider the pad material and check the compatibility of pad material and workpiece. Reconsider the pad form. (Changes to rib, groove, blast options) Reconsider the pad diameter and quantity of pads.

JP3

JP3E

JP2

JP2V

JP

JPZ  
JPZR

XT661

# Model Selection

## ● Non-conformance Examples

Phenomenon	Possible causes	Countermeasure
No problem occurs during the test, but adsorption becomes unstable after starting operation.	<ul style="list-style-type: none"> <li>Setting of the vacuum switch is not appropriate. Supply pressure is unstable. Vacuum pressure does not reach the set pressure.</li> <li>There is leakage between the workpiece and the vacuum pad.</li> </ul>	<ol style="list-style-type: none"> <li>Set the pressure for the vacuum equipment (supply pressure, if using an ejector) to the necessary vacuum pressure during the adsorption of the workpieces. And set the set pressure for the vacuum switch to the necessary vacuum pressure for adsorption.</li> <li>It is presumed that there was leakage during the test, but it was not serious enough to prevent adsorption. Reconsider the vacuum ejector and the shape, diameter, and material of the vacuum pad. Reconsider the vacuum pad.</li> </ol>
Adsorption becomes unstable after replacing the pad.	<ul style="list-style-type: none"> <li>Initial setting conditions (vacuum pressure, vacuum switch setting, height of the pad) have changed. Settings have changed because the pad was worn out or had permanent setting due to the operating environment.</li> <li>When the pad was replaced, leakage was generated from the screw connection part, or the engagement between the pad and the adapter.</li> </ul>	<ol style="list-style-type: none"> <li>Reconsider the operating conditions including vacuum pressure, the set pressure of the vacuum switch, and the height of the pad.</li> <li>Reconsider the engagement.</li> </ol>
Identical pads are used to adsorb identical workpieces, but some of the pads cannot adsorb the workpieces.	<ul style="list-style-type: none"> <li>There is leakage between the workpiece and the vacuum pad.</li> <li>The supply circuit for the cylinder, the solenoid valve and the ejector is in the same pneumatic circuit system. The supply pressure decreases when they are used simultaneously. (Vacuum pressure does not increase.)</li> <li>There is leakage from the screw connection part or the engagement between the pad and the adapter.</li> </ul>	<ol style="list-style-type: none"> <li>Reconsider the pad diameter, shape, material, vacuum ejector (suction flow rate), etc.</li> <li>Reconsider the pneumatic circuit.</li> <li>Reconsider the engagement.</li> </ol>
Generation of sticking of bellows of the bellows pad and/or recovery delays. (It may occur at an early stage.)	When the vacuum pad (bellows type) reaches the end of its life, weakening of bent parts, wearing, or sticking of rubber parts occurs.	The operating conditions will determine the product life. Inspect it sufficiently and determine the replacement time. <ul style="list-style-type: none"> <li>Replace pads.</li> <li>Reconsider the diameter, form, and material of vacuum pads.</li> <li>Reconsider the quantity of vacuum pads.</li> </ul>
	Vacuum pressure is higher than necessary, so excessive force (adhesiveness of the rubber + vacuum pressure) is applied to the pad (rubber part).	Reduce the vacuum pressure. If inadequate lifting force causes a problem in transferring the workpieces due to the reduction of vacuum pressure, increase the number of pads.
	Load is applied to the bellows due to the following operations, leading to sticking of rubber parts or reduction of the pad recovery performance. <ul style="list-style-type: none"> <li>Pushing exceeding pad displacement (operating range), external load.</li> <li>Workpiece holding/waiting</li> </ul> Waiting 10 seconds or more while the workpiece is being held <ul style="list-style-type: none"> <li>Even when under 10 seconds, pads sticking or a recovery delay issues may occur earlier depending on the operating environment and operating method.</li> </ul> Longer workpiece holding times lead to longer recovery times and a shorter life.	Reduce the load applied to the pad. <ul style="list-style-type: none"> <li>Review the equipment so that an external load exceeding the pad displacement (operating range) is not applied.</li> <li>Avoid workpiece holding and waiting.</li> </ul> The operating conditions will determine the product life. Inspect it and determine the replacement time.
The product life is shortened after replacement of the product (pad, buffer, etc.).	<ul style="list-style-type: none"> <li>The settings of the product changed.</li> <li>Tube had been pulled.</li> <li>Unbalanced load in clockwise direction increased.</li> <li>The transfer speed increased.</li> <li>The workpiece to be transferred was changed. (Shape, center of gravity, weight, etc.)</li> <li>The mounting orientation was at an angle.</li> <li>The operating environment changed.</li> <li>The buffer (mounting nut) was not tightened with the appropriate torque.</li> </ul>	If the problem (cannot adsorb) does not occur when starting operation, the product may reach the end of its life due to the customer's specification conditions. Reconsider the piping and operation (specifications). The selected model may not be appropriate for the current workpiece to be transferred or the specifications. Select the product model again by reconsidering the pad shape, diameter, quantity, and suction balance.
Pad comes out from the adapter during operation. Cracks are generated on the pad.	Load is applied to the pad (rubber part) due to the following factors. <ul style="list-style-type: none"> <li>Inadequate lifting force</li> <li>Incorrect suction balance</li> <li>Loads due to transfer acceleration are not considered when selecting the product model.</li> </ul>	The selected model may not be appropriate for the current workpiece to be transferred or the specifications. Select the product model again by reconsidering the pad shape, diameter, quantity, and suction balance.

Phenomenon	Possible causes	Countermeasure
Cracks are generated on the rubber (NBR, conductive NBR). 	<ul style="list-style-type: none"> <li>The product is operated in an ozone environment.</li> <li>An ionizer is used.</li> <li>* This phenomenon occurs earlier if pushing or the high vacuum pressure is used.</li> </ul>	Reconsider the operating environment. Reconsider the materials to be used.
Even when a mark-free pad is used, the pad end wears out quickly. (Suction marks are generated.)	If the pad adsorbs a highly clean workpiece, slippage is minimized, and a load (impact) is applied to the pad end.	Use the following products. <ul style="list-style-type: none"> <li>Stuck fluororesin pad</li> <li>Clean attachment</li> </ul>
Even when a mark-free pad is used, suction marks are generated.	<ul style="list-style-type: none"> <li>Incorrect application (The mark was generated due to a deformation.)</li> <li>Contamination (insufficient cleaning) on the pad when installing the equipment, dust in the operating environment etc.</li> </ul>	Check the mark generated on the workpiece. <ol style="list-style-type: none"> <li>Mark due to deformed (lined) workpiece Reconsider the pad diameter, form, material, vacuum ejector (suction flow rate), etc.</li> <li>Mark due to worn rubber Reconsider the pad diameter, form, material, vacuum ejector (suction flow rate), etc.</li> <li>Mark generated by moving components If the suction mark disappears or becomes smaller after wiping with cloth or waste cloth (without using solutions), clean the pad as it may have been contaminated. Refer to "Cleaning method (Mark-free NBR pad)" on page 12 of this catalog.</li> </ol>

## ■ When mounted with the nut, sometimes the buffer operation is not smooth, or the buffer does not slide.

### [Possible causes]

- The tightening torque of the nut for mounting the buffer is too high.
- Particles stuck to the sliding surface, or it is scratched.
- Lateral load applied to the piston rod, causing eccentric wearing.

### [Remedy]

Tighten the nut to the recommended tightening torque.

The nut may become loose depending on the operating conditions and environment. Be sure to perform regular maintenance.

#### Recommended Tightening Torque

Pad diameter	Product specifications		Tightening torque [N·m]
	Product part no.	Mounting thread size	
ø32 to ø50	ZP3E-(T/Y)(32 to 50)(UM/BM)**JB■	M18 x 1.5	28 to 32
	ZP3E-(T/Y)F(32 to 50)(UM/BM)**JB■		
ø63 to ø125	ZP3E-(T/Y)(63 to 125)(UM/BM)**JB■	M22 x 1.5	45 to 50
	ZP3E-(T/Y)F(63 to 125)(UM/BM)**JB■		

## ● Time of Replacement of Vacuum Pad

### The vacuum pad is disposable. Replace it on a regular basis.

Continued use of the vacuum pad will cause wear and tear on the adsorption surface, and the exterior dimensions will gradually get smaller and smaller. As the pad diameter gets smaller, lifting force will decrease, though adsorption is possible. It is extremely difficult to provide advice on the frequency of vacuum pad exchange. This is because there are numerous factors at work, including surface roughness, operating environment (temperature, humidity, ozone, solvents, etc.), and operating conditions (vacuum pressure, workpiece weight, pressing force of the vacuum pad on the workpiece, presence or absence of a buffer, etc.).

(Weakening of bent parts, wear, or sticking of rubber parts may occur with the bellows type pad.)

Thus, the customer should decide when the vacuum pad should be exchanged, based on its condition at time of initial use.

The bolt may become loose depending on the operating conditions and environment. Be sure to perform regular maintenance.

ZP3

ZP3E

ZP2

ZP2V

ZP

ZPT

ZPR

XT661



# Flat Type Pad/Bellows Type Pad with Groove

Pad diameter  $\phi 32, \phi 40, \phi 50, \phi 63, \phi 80, \phi 100, \phi 125$

Symbol/Form

UM: Flat type with groove  
BM: Bellows type with groove

## How to Order

Pad unit **ZP3E-32UMN-P**

### Pad diameter

Symbol	Pad diameter
32	$\phi 32$
40	$\phi 40$
50	$\phi 50$
63	$\phi 63$
80	$\phi 80$
100	$\phi 100$
125	$\phi 125$

### Pad form

Symbol	Form
UM	Flat type with groove
BM	Bellows type with groove

### Plate (★)

Nii	None
P	With plate

### Pad material

Symbol	Material
N	NBR
S	Silicone rubber
U	Urethane rubber
F	FKM
CL	Mark-free NBR



### Plate Unit Part No.

Model	Form/Diameter						Flat type with groove (UM)						Bellows type with groove (BM)					
	32	40	50	63	80	100/125	32	40	50	63	80	100/125	32	40	50	63	80	100/125
ZP3EA-P1	●	●	—	—	—	—	●	●	—	—	—	—	—	—	—	—	—	—
ZP3EA-P2	—	—	●	—	—	—	—	—	●	—	—	—	—	—	—	—	—	—
ZP3EA-P3	—	—	—	●	●	—	—	—	—	●	—	—	—	—	—	—	—	—
ZP3EA-P4	—	—	—	—	●	—	—	—	—	—	●	—	—	—	—	—	—	—
ZP3EA-P5	—	—	—	—	—	●	—	—	—	—	—	●	—	—	—	—	—	—
ZP3EA-P6	—	—	—	—	—	—	—	—	—	—	—	—	—	—	—	—	—	●

Pad diameter  $\phi 32$  to  $\phi 50$

Pad form Flat type with groove

## Dimensions: Pad Unit



### ZP3E-32UM□-★

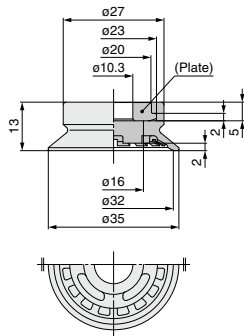

### ZP3E-40UM□-★

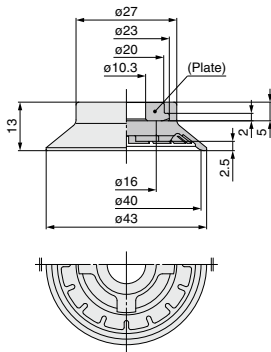

### ZP3E-50UM□-★

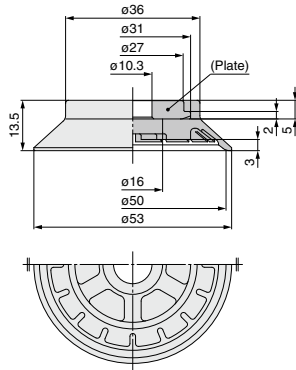

### Weights

Model	Pad material [g]		
	N/U/CL	S	F
ZP3E-32UM□	4.2	3.9	6.7
ZP3E-32UM□-P	7.9	7.6	10.4

### Weights

Model	Pad material [g]		
	N/U/CL	S	F
ZP3E-40UM□	5.3	4.9	8.4
ZP3E-40UM□-P	9.0	8.5	12.1

### Weights

Model	Pad material [g]		
	N/U/CL	S	F
ZP3E-50UM□	9.4	8.7	14.9
ZP3E-50UM□-P	17.1	16.3	22.5



**Dimensions: Pad Unit** Pad diameter  $\phi 63$  to  $\phi 125$   
 Pad form Flat type with groove

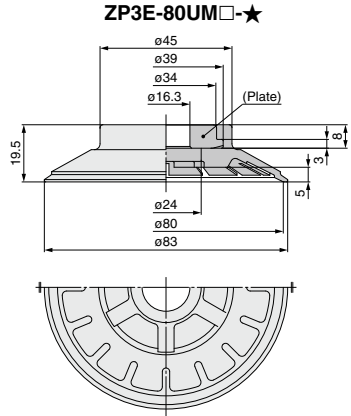
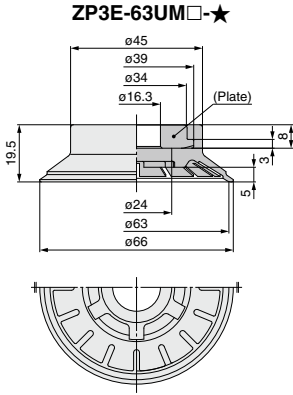

**Weights** [g]

Model	Pad material	N/U/CL	S	F
ZP3E-63UM $\square$		18.2	16.7	28.8
ZP3E-63UM $\square$ -P		35.9	34.4	46.5

**Weights** [g]

Model	Pad material	N/U/CL	S	F
ZP3E-80UM $\square$		26.4	24.3	41.9
ZP3E-80UM $\square$ -P		44.1	42.0	59.6

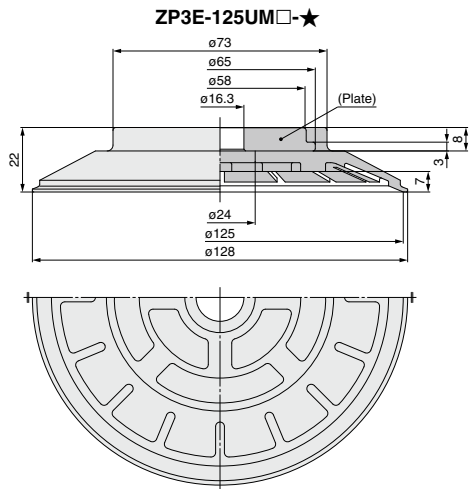
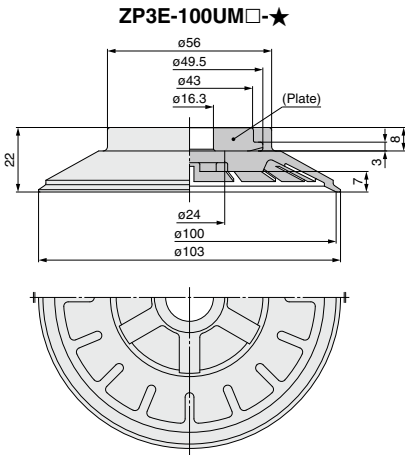

**Weights** [g]

Model	Pad material	N/U/CL	S	F
ZP3E-100UM $\square$		44.7	40.9	70.7
ZP3E-100UM $\square$ -P		75.8	72.0	102

**Weights** [g]

Model	Pad material	N/U/CL	S	F
ZP3E-125UM $\square$		79.3	72.7	126
ZP3E-125UM $\square$ -P		140	134	187

ZP3  
 ZP3E  
 ZP2  
 ZP2V  
 ZP  
 ZPT  
 ZPR  
 XT661

# ZP3E Series

Dimensions: Pad Unit

Pad diameter  $\phi 32$  to  $\phi 80$

Pad form Bellows type with groove



ZP3E-32BM□-★

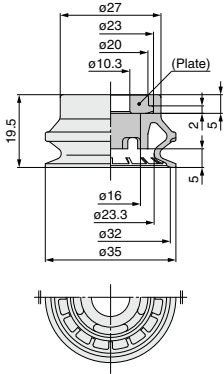

ZP3E-40BM□-★

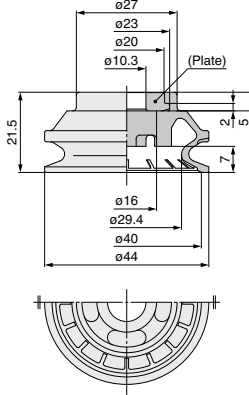

ZP3E-50BM□-★

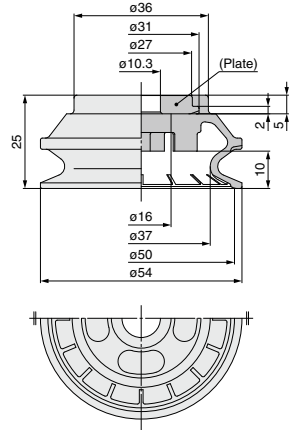

**Weights** [g]

Model	Pad material	N/U/CL	S	F
ZP3E-32BM□		6.2	5.7	9.9
ZP3E-32BM□-P		9.9	9.4	13.6

**Weights** [g]

Model	Pad material	N/U/CL	S	F
ZP3E-40BM□		10.2	9.4	16.2
ZP3E-40BM□-P		13.9	13.0	19.9

**Weights** [g]

Model	Pad material	N/U/CL	S	F
ZP3E-50BM□		17.9	16.4	28.4
ZP3E-50BM□-P		25.5	24.0	36.0

ZP3E-63BM□-★

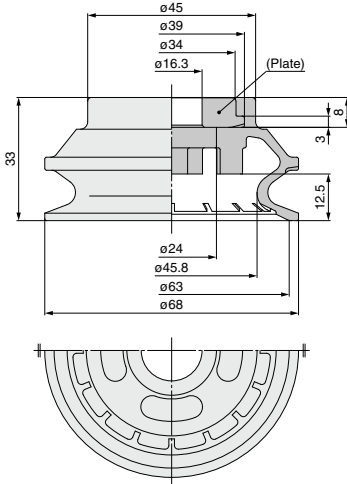

ZP3E-80BM□-★

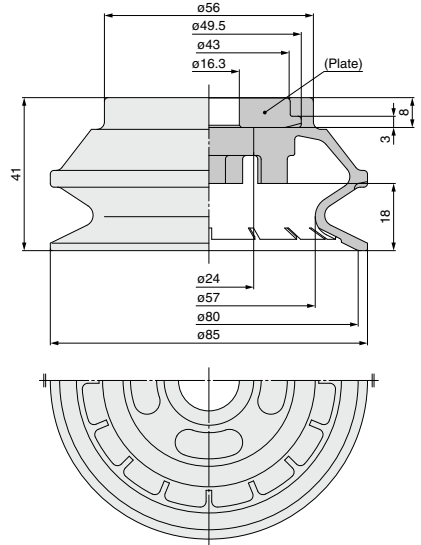

**Weights** [g]

Model	Pad material	N/U/CL	S	F
ZP3E-63BM□		34.8	31.9	55.1
ZP3E-63BM□-P		52.5	49.6	72.8

**Weights** [g]

Model	Pad material	N/U/CL	S	F
ZP3E-80BM□		60.2	55.2	95.3
ZP3E-80BM□-P		91.3	86.3	126



**Dimensions: Pad Unit** Pad diameter  $\phi 100, \phi 125$   
 Pad form Bellows type with groove

**ZP3E-100BM□-★**

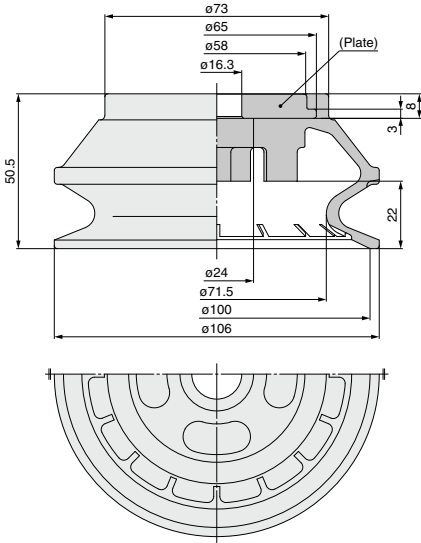

**ZP3E-125BM□-★**

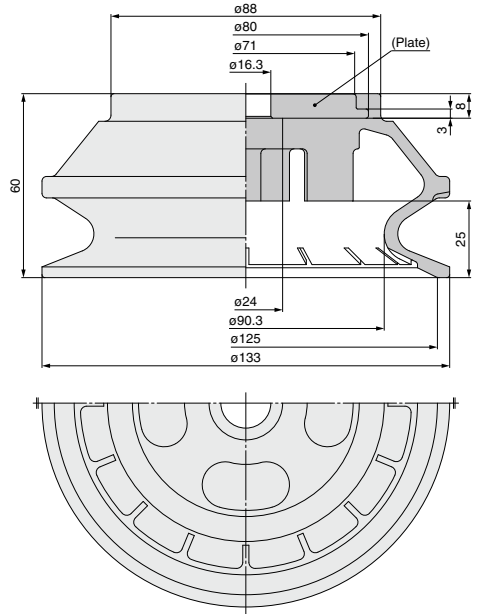

**Weights** [g]

Model	Pad material	N/U/CL	S	F
ZP3E-100BM□		125	114	197
ZP3E-100BM□-P		186	175	258

**Weights** [g]

Model	Pad material	N/U/CL	S	F
ZP3E-125BM□		235	216	372
ZP3E-125BM□-P		329	310	466

ZP3

ZP3E

ZP2

ZP2V

ZP

ZPT

ZPR

XT661

# ZP3E Series

## How to Order



Vertical vacuum inlet  
With adapter

### ZP3E - T 32 UM N - A10

#### Vacuum inlet direction

Symbol	Direction
T	Vertical

#### Pad diameter

Symbol	Pad diameter
32	ø32
40	ø40
50	ø50
63	ø63
80	ø80
100	ø100
125	ø125

#### Pad form

Symbol	Form
UM	Flat type with groove
BM	Bellows type with groove

#### Mounting thread size

	Symbol	Mounting Thread size	ø32 to ø50		ø63 to ø125	
			●	—	●	—
Male thread	For direct mounting	A10	M10 x 1	●	—	—
		A16	M16 x 1.5	—	●	—
	For plate connection	AL14 <sup>*</sup>	M14 x 1	●	—	—
		AL16 <sup>*</sup>	M16 x 1.5	—	●	—
Female thread	B8	M8 x 1.25	●	—	—	
	B10	M10 x 1.5	●	—	—	
	B12	M12 x 1.75	—	●	—	
	B18	M18 x 1.5	—	—	●	

\* Male thread AL14/AL16 connection types have a vacuum exhaust (female thread) port separate from the mounting screw.

#### Pad material

Symbol	Material
N	NBR
S	Silicone rubber
U	Urethane rubber
F	FKM
CL	Mark-free NBR

\* Refer to pages 471 and 472 for replacement parts.

## Dimensions/With Set Screw: Vacuum Inlet

Vertical

Pad diameter ø32 to ø50

Pad form Flat type with groove



### ZP3E-T32UM□-A10

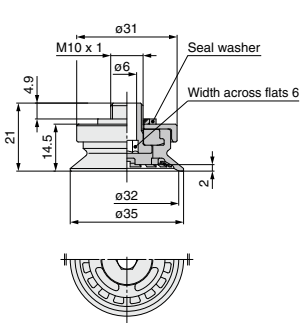

### ZP3E-T40UM□-A10

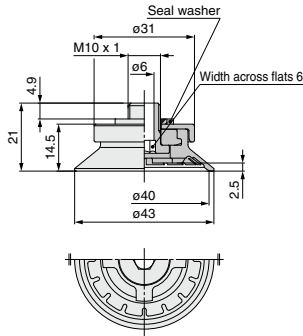

### ZP3E-T50UM□-A10

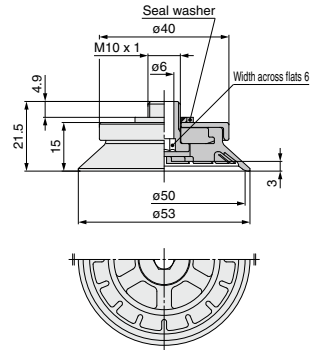

#### Weights

[g]

Model	Pad material		
	N/U/CL	S	F
ZP3E-T32UM□-A10	22.1	21.8	24.6

#### Weights

[g]

Model	Pad material		
	N/U/CL	S	F
ZP3E-T40UM□-A10	23.2	22.7	26.2

#### Weights

[g]

Model	Pad material		
	N/U/CL	S	F
ZP3E-T50UM□-A10	33.8	33.0	39.2



Dimensions/With Set Screw: Vacuum Inlet **Vertical**

Pad diameter  $\phi 63$  to  $\phi 125$

Pad form Flat type with groove



**ZP3E-T63UM□-A16**

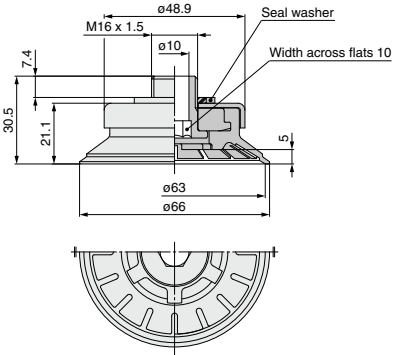

**ZP3E-T80UM□-A16**

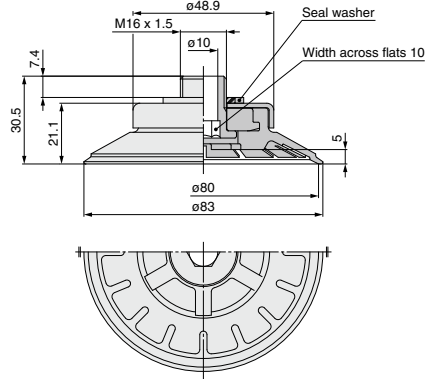

**Weights** [g]

Model	Pad material	N/U/CL	S	F
ZP3E-T63UM□-A16		35.9	34.4	46.5

**Weights** [g]

Model	Pad material	N/U/CL	S	F
ZP3E-T80UM□-A16		44.1	42.0	59.6

**ZP3E-T100UM□-A16**

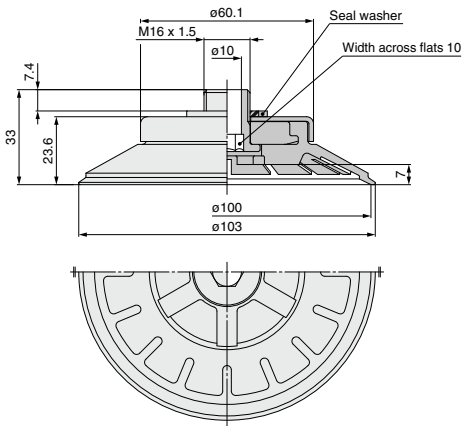

**ZP3E-T125UM□-A16**

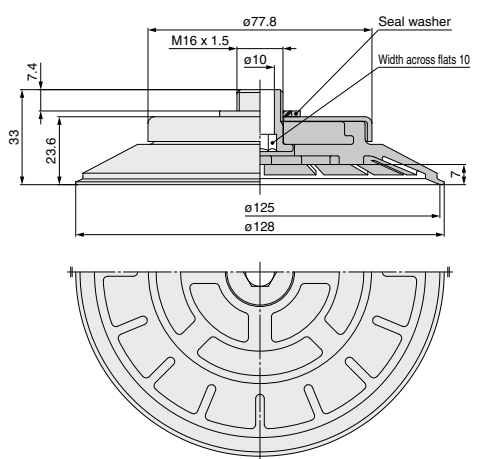

**Weights** [g]

Model	Pad material	N/U/CL	S	F
ZP3E-T100UM□-A16		75.8	72.0	102

**Weights** [g]

Model	Pad material	N/U/CL	S	F
ZP3E-T125UM□-A16		140	134	187

ZP3

ZP3E

ZP2

ZP2V

ZP

ZPT

ZPR

XT661

# ZP3E Series



Dimensions/With Male Thread Adapter: Vacuum Inlet **Vertical**

Pad diameter  $\phi 32$  to  $\phi 80$

Pad form Flat type with groove

## ZP3E-T32UM□-AL14

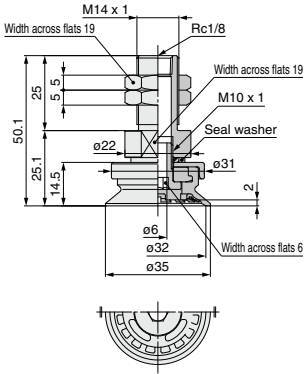

## ZP3E-T40UM□-AL14

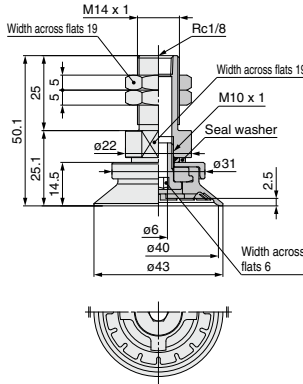

## ZP3E-T50UM□-AL14

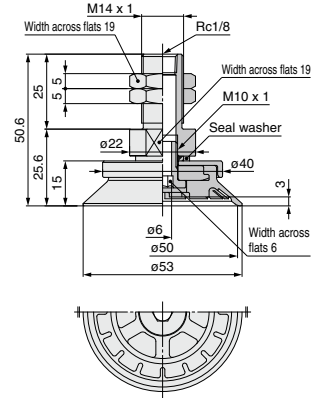

**Weights** [g]

Model	Pad material	N/U/CL	S	F
ZP3E-T32UM□-AL14		49.1	48.8	51.6

**Weights** [g]

Model	Pad material	N/U/CL	S	F
ZP3E-T40UM□-AL14		50.2	49.7	53.2

**Weights** [g]

Model	Pad material	N/U/CL	S	F
ZP3E-T50UM□-AL14		60.8	60.0	66.2

## ZP3E-T63UM□-AL16

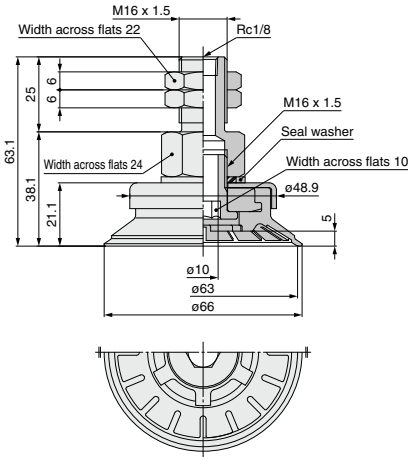

## ZP3E-T80UM□-AL16

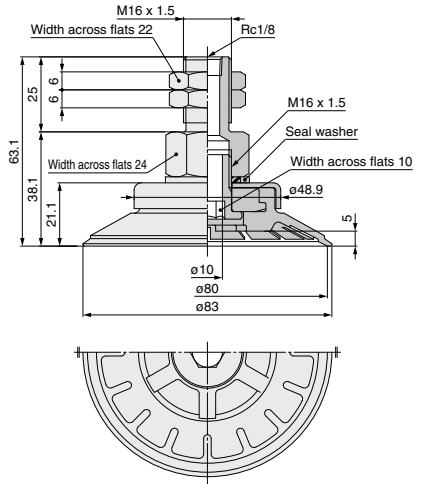

**Weights** [g]

Model	Pad material	N/U/CL	S	F
ZP3E-T63UM□-AL16		199	198	210

**Weights** [g]

Model	Pad material	N/U/CL	S	F
ZP3E-T80UM□-AL16		208	206	223

Dimensions/With Male Thread Adapter: Vacuum Inlet

Pad diameter  $\phi 100, \phi 125$

Pad form Flat type with groove



**ZP3E-T100UM□-AL16**

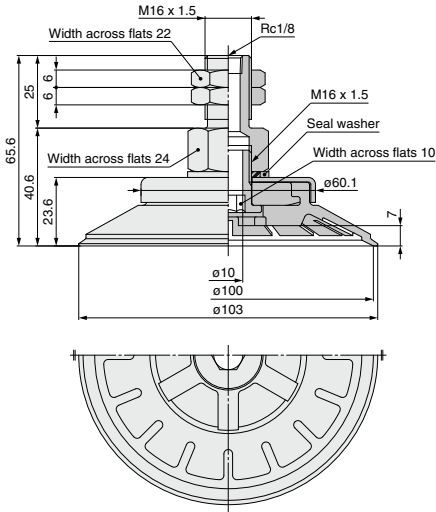

**ZP3E-T125UM□-AL16**

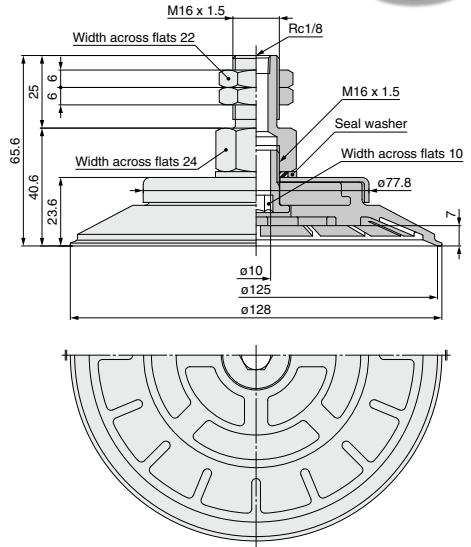

**Weights** [g]

Model	Pad material	N/U/CL	S	F
ZP3E-T100UM□-AL16		254	250	280

**Weights** [g]

Model	Pad material	N/U/CL	S	F
ZP3E-T125UM□-AL16		347	341	394

ZP3

ZP3E

ZP2

ZP2V

ZP

ZPT

ZPR

XT661

# ZP3E Series

Dimensions/With Female Thread Adapter: Vacuum Inlet

Vertical

Pad diameter  $\phi 32$  to  $\phi 80$

Pad form Flat type with groove



ZP3E-T32UM□-B8  
ZP3E-T32UM□-B10

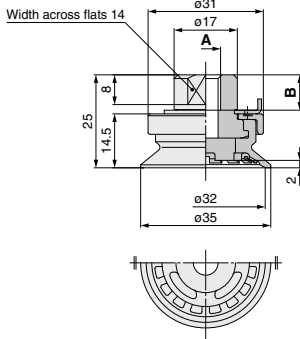

ZP3E-T40UM□-B8  
ZP3E-T40UM□-B10

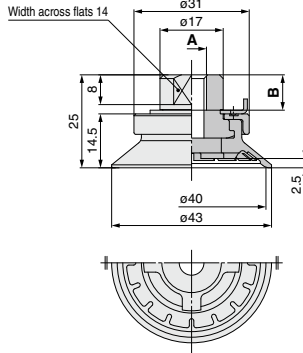

ZP3E-T50UM□-B8  
ZP3E-T50UM□-B10

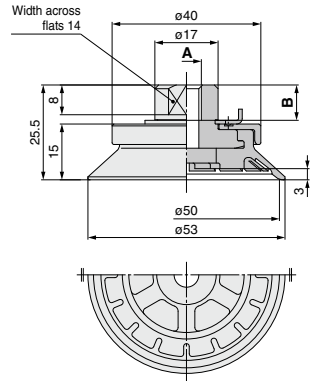

## Dimensions

Model	A	B
ZP3E-T32UM□-B8	M8 x 1.25	9.5
ZP3E-T32UM□-B10	M10 x 1.5	13

Model	Weight [g]/Pad material		
	N/U/CL	S	F
ZP3E-T32UM□-B8	20.6	20.3	23.1
ZP3E-T32UM□-B10	19.2	18.9	21.7

## Dimensions

Model	A	B
ZP3E-T40UM□-B8	M8 x 1.25	9.5
ZP3E-T40UM□-B10	M10 x 1.5	13

Model	Weight [g]/Pad material		
	N/U/CL	S	F
ZP3E-T40UM□-B8	21.7	21.2	24.8
ZP3E-T40UM□-B10	20.3	19.8	23.4

## Dimensions

Model	A	B
ZP3E-T50UM□-B8	M8 x 1.25	9.5
ZP3E-T50UM□-B10	M10 x 1.5	13

Model	Weight [g]/Pad material		
	N/U/CL	S	F
ZP3E-T50UM□-B8	32.5	31.7	38.0
ZP3E-T50UM□-B10	31.1	30.3	36.6

ZP3E-T63UM□-B12  
ZP3E-T63UM□-B18

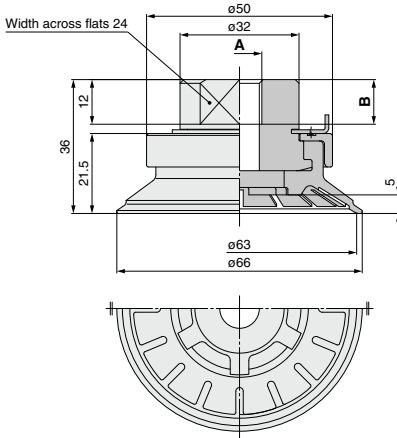

ZP3E-T80UM□-B12  
ZP3E-T80UM□-B18

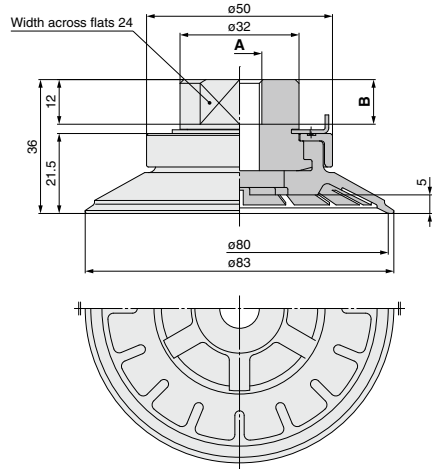

## Dimensions

Model	A	B	Weight [g]/Pad material		
			N/U/CL	S	F
ZP3E-T63UM□-B12	M12 x 1.75	12	86.0	84.5	96.6
ZP3E-T63UM□-B18	M18 x 1.5	18	75.9	74.4	86.5

## Dimensions

Model	A	B	Weight [g]/Pad material		
			N/U/CL	S	F
ZP3E-T80UM□-B12	M12 x 1.75	12	94.2	92.1	110
ZP3E-T80UM□-B18	M18 x 1.5	18	84.1	82.0	99.6

Dimensions/With Female Thread Adapter: Vacuum Inlet

 Vertical

Pad diameter  $\phi 100, \phi 125$

Pad form Flat type with groove



**ZP3E-T100UM□-B12**  
**ZP3E-T100UM□-B18**

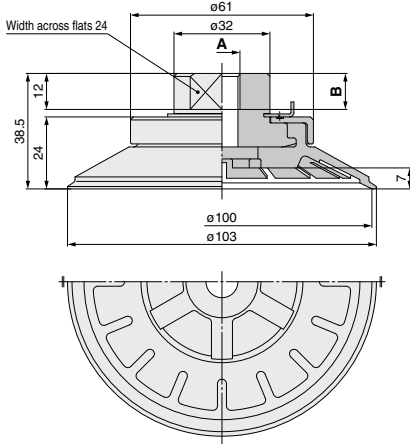

**ZP3E-T125UM□-B12**  
**ZP3E-T125UM□-B18**

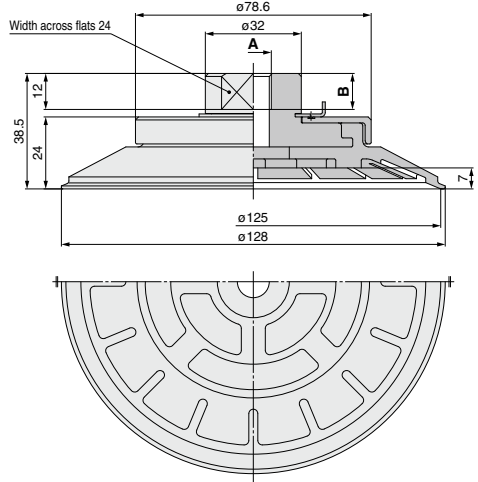

**Dimensions**

Model	A	B	Weight [g]/Pad material		
			N/U/CL	S	F
ZP3E-T100UM□-B12	M12 x 1.75	12	132	128	158
ZP3E-T100UM□-B18	M18 x 1.5	18	122	118	148

**Dimensions**

Model	A	B	Weight [g]/Pad material		
			N/U/CL	S	F
ZP3E-T125UM□-B12	M12 x 1.75	12	210	203	256
ZP3E-T125UM□-B18	M18 x 1.5	18	200	193	246

ZP3

ZP3E

ZP2

ZP2V

ZP

ZPT  
ZPR

XT661

# ZP3E Series

Dimensions/With Set Screw: Vacuum Inlet



Pad diameter  $\phi 32$  to  $\phi 80$

Pad form Bellows type with groove



ZP3E-T32BM□-A10

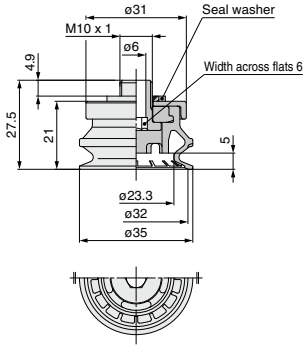

ZP3E-T40BM□-A10

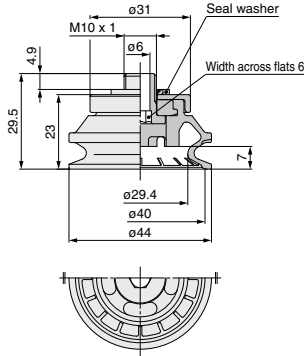

ZP3E-T50BM□-A10

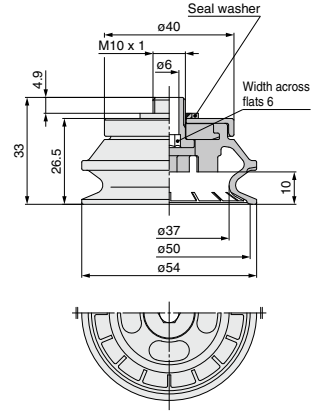

**Weights**

Model	Pad material		
	N/U/CL	S	F
ZP3E-T32BM□-A10	24.1	23.6	27.7

**Weights**

Model	Pad material		
	N/U/CL	S	F
ZP3E-T40BM□-A10	28.1	27.2	34.1

**Weights**

Model	Pad material		
	N/U/CL	S	F
ZP3E-T50BM□-A10	42.2	40.7	52.7

ZP3E-T63BM□-A16

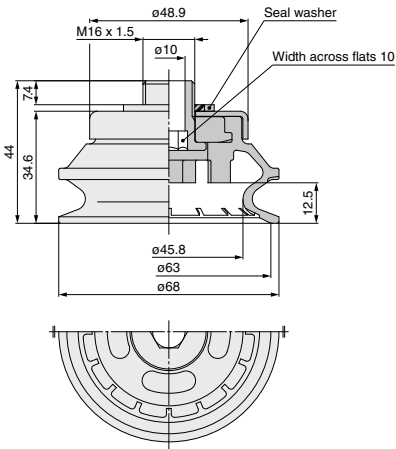

ZP3E-T80BM□-A16

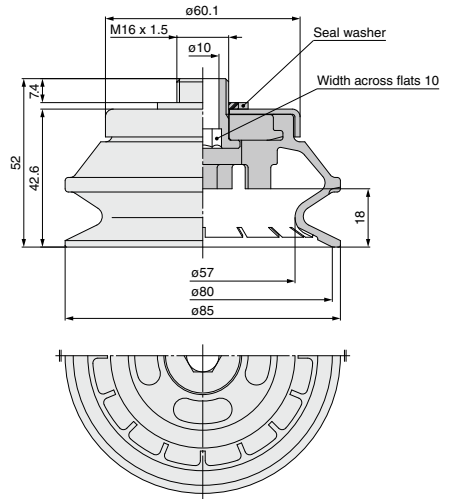

**Weights**

Model	Pad material		
	N/U/CL	S	F
ZP3E-T63BM□-A16	116	113	137

**Weights**

Model	Pad material		
	N/U/CL	S	F
ZP3E-T80BM□-A16	170	165	205

**Dimensions/With Set Screw: Vacuum Inlet**

**Vertical**

**Pad diameter**  $\phi 100, \phi 125$

**Pad form** Bellows type with groove



**ZP3E-T100BM□-A16**

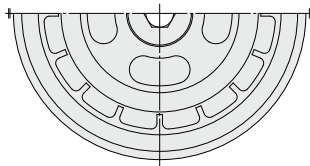
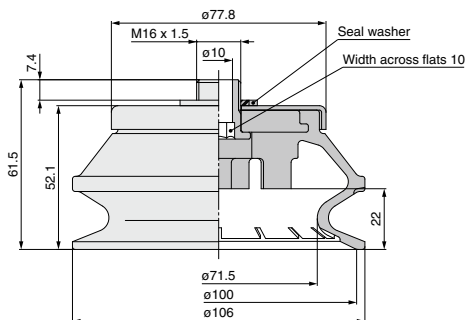

**ZP3E-T125BM□-A16**

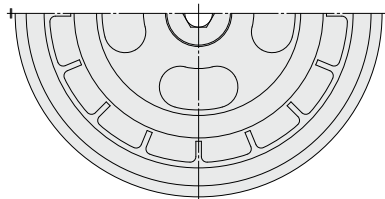
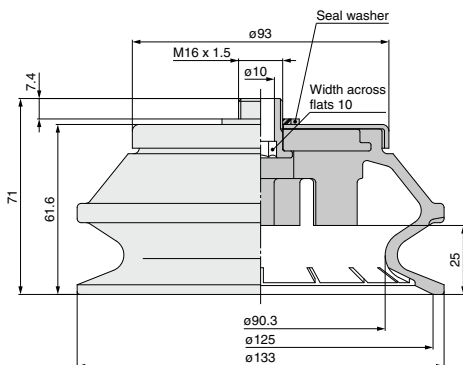

**Weights**

[g]

Model	Pad material		
	N/U/CL	S	F
ZP3E-T100BM□-A16	293	282	365

**Weights**

[g]

Model	Pad material		
	N/U/CL	S	F
ZP3E-T125BM□-A16	466	447	603

ZP3

ZP3E

ZP2

ZP2V

ZP

ZPT

ZPR

XT661

# ZP3E Series

Dimensions/With Male Thread Adapter: Vacuum Inlet

Vertical

Pad diameter  $\phi 32$  to  $\phi 80$

Pad form Bellows type with groove



ZP3E-T32BM□-AL14

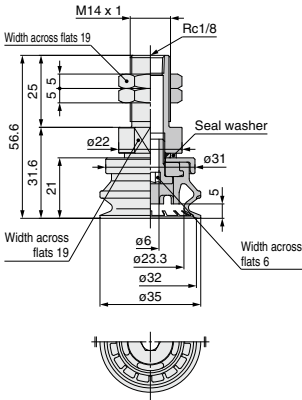

ZP3E-T40BM□-AL14

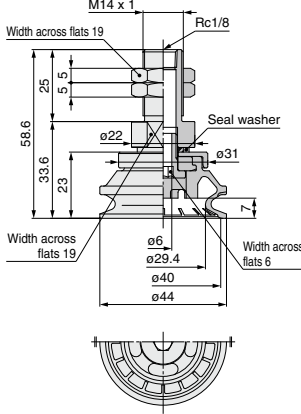

ZP3E-T50BM□-AL14

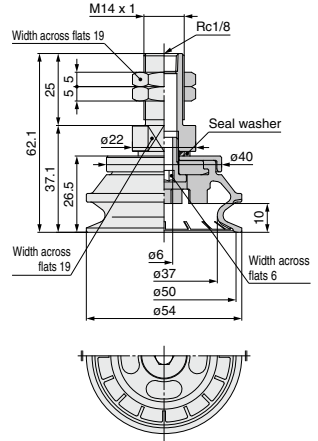

**Weights**

Model	Pad material		
	N/U/CL	S	F
ZP3E-T32BM□-AL14	51.1	50.6	54.7

**Weights**

Model	Pad material		
	N/U/CL	S	F
ZP3E-T40BM□-AL14	55.1	54.2	61.1

**Weights**

Model	Pad material		
	N/U/CL	S	F
ZP3E-T50BM□-AL14	69.2	67.7	79.7

ZP3E-T63BM□-AL16

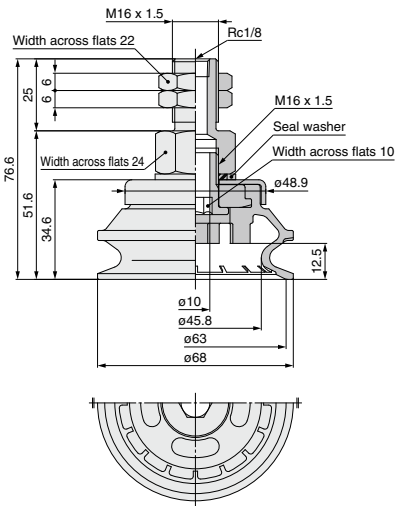

ZP3E-T80BM□-AL16

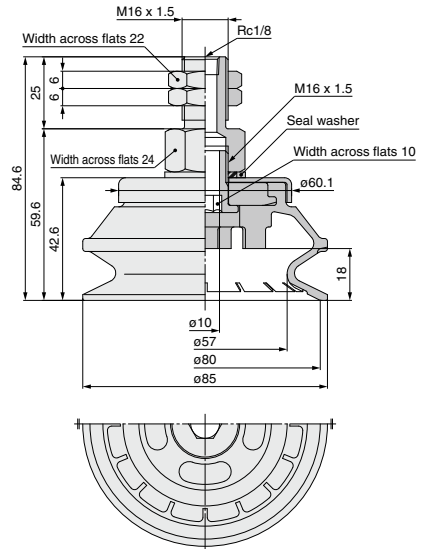

**Weights**

Model	Pad material		
	N/U/CL	S	F
ZP3E-T63BM□-AL16	216	213	236

**Weights**

Model	Pad material		
	N/U/CL	S	F
ZP3E-T80BM□-AL16	270	265	305



**Dimensions/With Male Thread Adapter: Vacuum Inlet** 

Pad diameter  $\phi 100, \phi 125$

Pad form Bellows type with groove



**ZP3E-T100BM□-AL16**

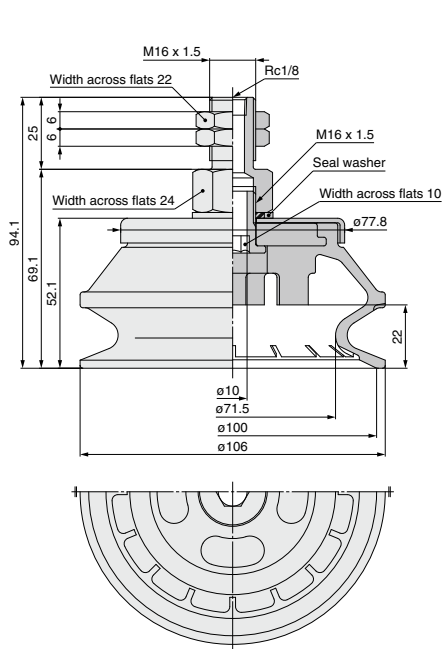

**ZP3E-T125BM□-AL16**

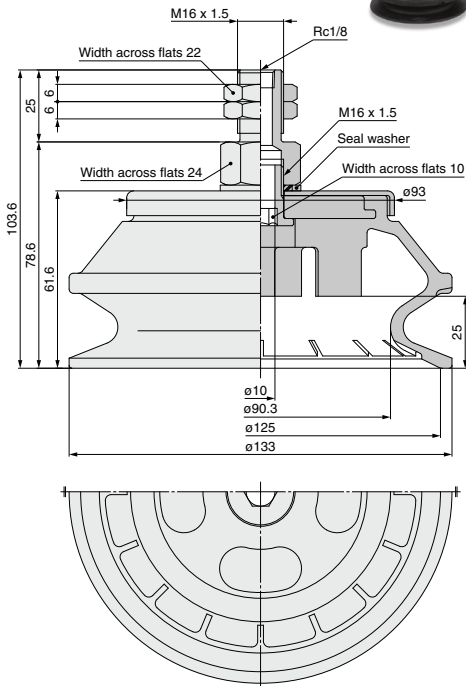

**Weights**

[g]

Model	Pad material	N/U/CL	S	F
ZP3E-T100BM□-AL16		393	382	465

**Weights**

[g]

Model	Pad material	N/U/CL	S	F
ZP3E-T125BM□-AL16		565	546	702

ZP3

ZP3E

ZP2

ZP2V

ZP

ZPT

ZPR

XT661

# ZP3E Series

Dimensions/With Female Thread Adapter: Vacuum Inlet

Vertical

Pad diameter  $\phi 32$  to  $\phi 80$

Pad form Bellows type with groove



ZP3E-T32BM□-B8  
ZP3E-T32BM□-B10

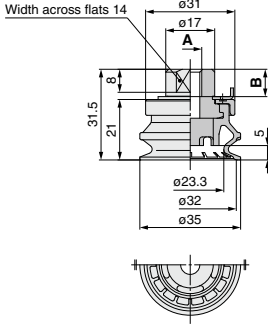

ZP3E-T40BM□-B8  
ZP3E-T40BM□-B10

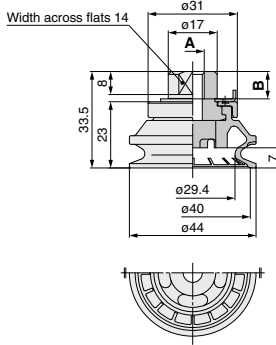

ZP3E-T50BM□-B8  
ZP3E-T50BM□-B10

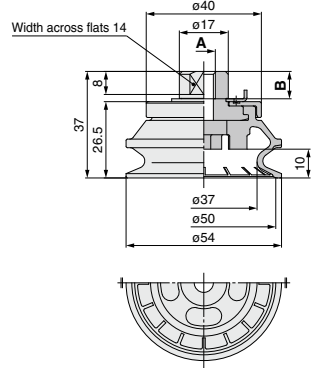

## Dimensions

Model	A	B
ZP3E-T32BM□-B8	M8 x 1.25	9.5
ZP3E-T32BM□-B10	M10 x 1.5	13

Model	Weight [g]/Pad material		
	N/U/CL	S	F
ZP3E-T32BM□-B8	22.6	22.1	26.3
ZP3E-T32BM□-B10	21.2	20.7	24.9

## Dimensions

Model	A	B
ZP3E-T40BM□-B8	M8 x 1.25	9.5
ZP3E-T40BM□-B10	M10 x 1.5	13

Model	Weight [g]/Pad material		
	N/U/CL	S	F
ZP3E-T40BM□-B8	26.6	25.7	32.6
ZP3E-T40BM□-B10	25.2	24.3	31.2

## Dimensions

Model	A	B
ZP3E-T50BM□-B8	M8 x 1.25	9.5
ZP3E-T50BM□-B10	M10 x 1.5	13

Model	Weight [g]/Pad material		
	N/U/CL	S	F
ZP3E-T50BM□-B8	41.0	39.5	51.5
ZP3E-T50BM□-B10	39.6	38.1	50.1

ZP3E-T63BM□-B12  
ZP3E-T63BM□-B18

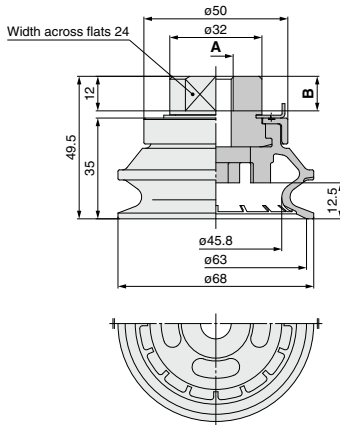

ZP3E-T80BM□-B12  
ZP3E-T80BM□-B18

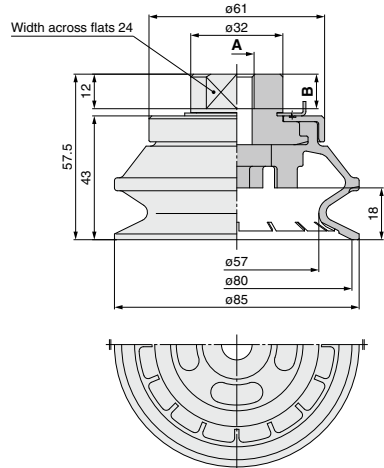

## Dimensions

Model	A	B	Weight [g]/Pad material		
			N/U/CL	S	F
ZP3E-T63BM□-B12	M12 x 1.75	12	103	100	123
ZP3E-T63BM□-B18	M18 x 1.5	18	92.5	89.6	113

## Dimensions

Model	A	B	Weight [g]/Pad material		
			N/U/CL	S	F
ZP3E-T80BM□-B12	M12 x 1.75	12	148	143	183
ZP3E-T80BM□-B18	M18 x 1.5	18	138	133	173

Dimensions/With Female Thread Adapter: Vacuum Inlet



Pad diameter  $\phi 100, \phi 125$

Pad form Bellows type with groove



**ZP3E-T100BM□-B12**  
**ZP3E-T100BM□-B18**

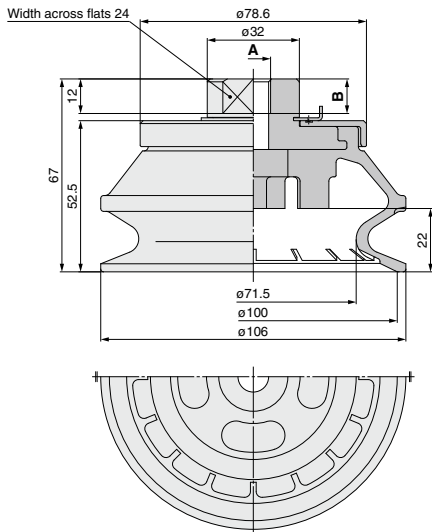

**ZP3E-T125BM□-B12**  
**ZP3E-T125BM□-B18**

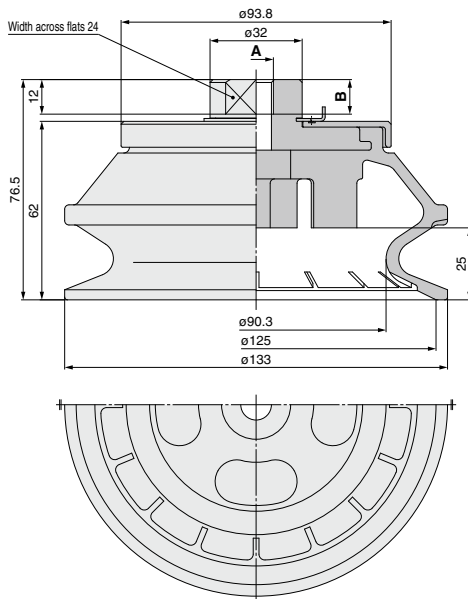

**Dimensions**

Model	A	B	Weight [g]/Pad material		
			N/U/CL	S	F
ZP3E-T100BM□-B12	M12 x 1.75	12	255	244	327
ZP3E-T100BM□-B18	M18 x 1.5	18	245	234	317

**Dimensions**

Model	A	B	Weight [g]/Pad material		
			N/U/CL	S	F
ZP3E-T125BM□-B12	M12 x 1.75	12	412	393	549
ZP3E-T125BM□-B18	M18 x 1.5	18	402	383	539

ZP3

ZP3E

ZP2

ZP2V

ZP

ZPT

ZPR

XT661

# ZP3E Series

## How to Order



Lateral vacuum inlet  
With adapter

**ZP3E - Y 32 UM N - AL14**

### Vacuum inlet direction

Symbol	Direction
Y	Lateral

### Pad diameter

Symbol	Pad diameter
32	ø32
40	ø40
50	ø50
63	ø63
80	ø80
100	ø100
125	ø125

### Pad form

Symbol	Form
UM	Flat type with groove
BM	Bellows type with groove

### Mounting thread size

	Symbol	Mounting Thread size	ø32 to ø50	ø63 to ø125
		Male thread	AL14 AL16	M14 x 1 M16 x 1.5
Female thread	B8 B12	M8 x 1.25 M12 x 1.75	● —	— ●

\* Male thread AL14/AL16 connection types have a vacuum exhaust (female thread) port separate from the mounting screw.

### Pad material

Symbol	Material
N	NBR
S	Silicone rubber
U	Urethane rubber
F	FKM
CL	Mark-free NBR

\* Refer to page 473 for replacement parts.

## Dimensions/With Male Thread Adapter: Vacuum Inlet

Lateral

Pad diameter ø32 to ø50

Pad form Flat type with groove



### ZP3E-Y32UM□-AL14

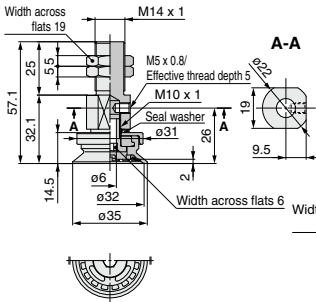

### ZP3E-Y40UM□-AL14

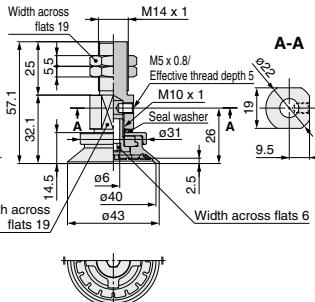

### ZP3E-Y50UM□-AL14

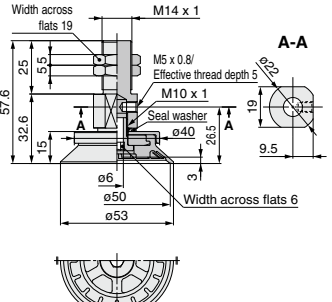

### Weights

[g]

Model	Pad material		
	N/U/CL	S	F
ZP3E-Y32UM□-AL14	58.4	58.1	60.9

### Weights

[g]

Model	Pad material		
	N/U/CL	S	F
ZP3E-Y40UM□-AL14	59.5	59.0	62.5

### Weights

[g]

Model	Pad material		
	N/U/CL	S	F
ZP3E-Y50UM□-AL14	70.1	69.3	75.5

**Dimensions/With Male Thread Adapter: Vacuum Inlet**

Lateral

**Pad diameter**  $\phi 63$  to  $\phi 125$

**Pad form** Flat type with groove



**ZP3E-Y63UM□-AL16**

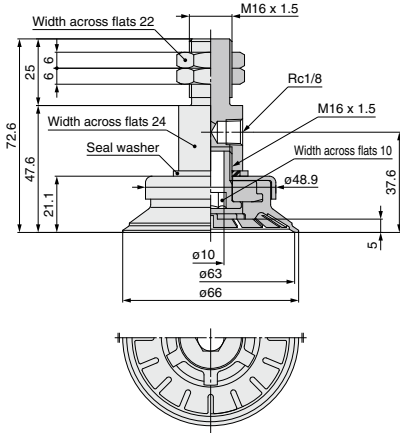

**Weights**

[g]

Model	Pad material		
	N/U/CL	S	F
ZP3E-Y63UM□-AL16	216	215	227

**ZP3E-Y80UM□-AL16**

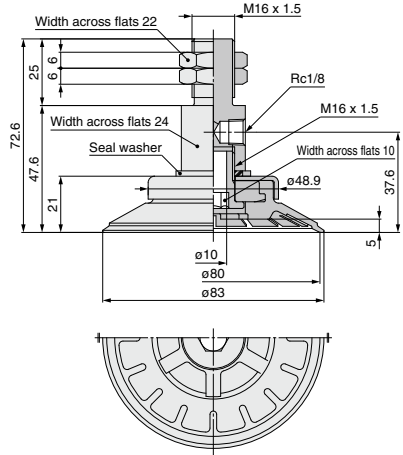

**Weights**

[g]

Model	Pad material		
	N/U/CL	S	F
ZP3E-Y80UM□-AL16	224	222	240

**ZP3E-Y100UM□-AL16**

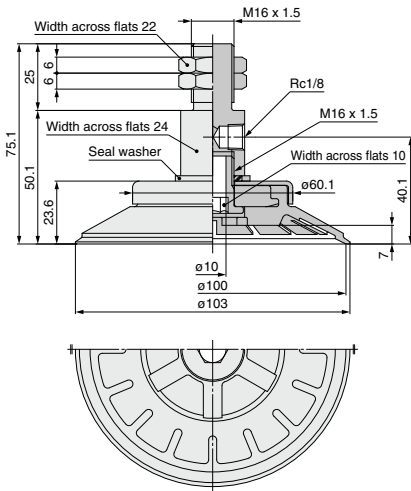

**Weights**

[g]

Model	Pad material		
	N/U/CL	S	F
ZP3E-Y100UM□-AL16	271	267	297

**ZP3E-Y125UM□-AL16**

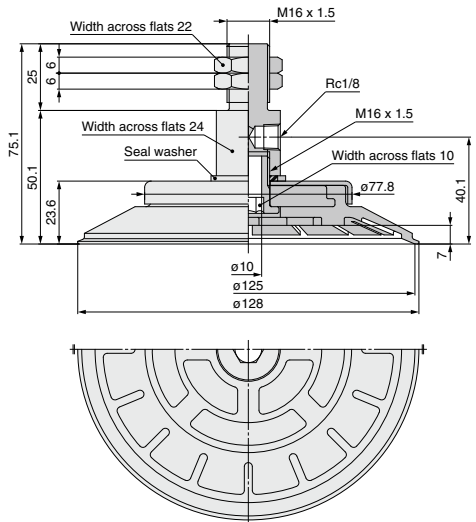

**Weights**

[g]

Model	Pad material		
	N/U/CL	S	F
ZP3E-Y125UM□-AL16	364	357	411

ZP3

ZP3E

ZP2

ZP2V

ZP

ZPT

ZPR

XT661

# ZP3E Series

Dimensions/With Female Thread Adapter: Vacuum Inlet

Lateral

Pad diameter  $\phi 32$  to  $\phi 80$

Pad form Flat type with groove



ZP3E-Y32UM□-B8

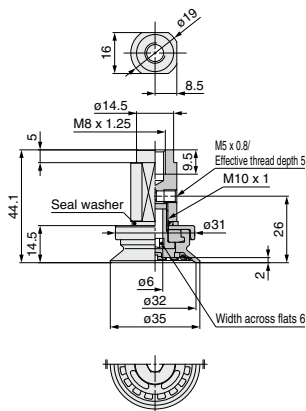

ZP3E-Y40UM□-B8

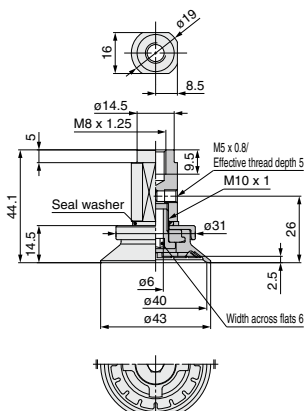

ZP3E-Y50UM□-B8

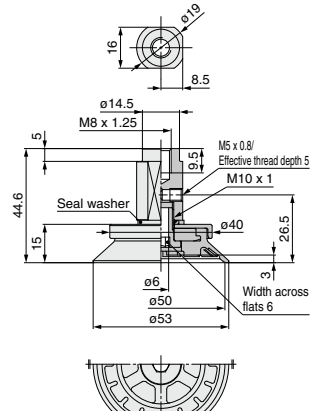

**Weights**

Model	Pad material		
	N/U/CL	S	F
ZP3E-Y32UM□-B8	36.8	36.5	39.3

**Weights**

Model	Pad material		
	N/U/CL	S	F
ZP3E-Y40UM□-B8	37.9	37.4	40.9

**Weights**

Model	Pad material		
	N/U/CL	S	F
ZP3E-Y50UM□-B8	48.5	47.7	53.9

ZP3E-Y63UM□-B12

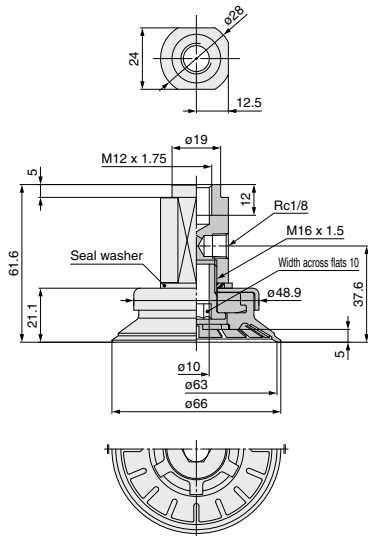

ZP3E-Y80UM□-B12

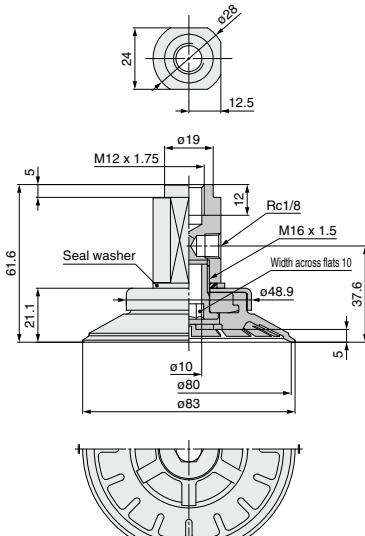

**Weights**

Model	Pad material		
	N/U/CL	S	F
ZP3E-Y63UM□-B12	142	140	153

**Weights**

Model	Pad material		
	N/U/CL	S	F
ZP3E-Y80UM□-B12	150	148	166

Dimensions/With Female Thread Adapter: Vacuum Inlet 

Pad diameter  $\phi 100, \phi 125$   
 Pad form Flat type with groove



**ZP3E-Y100UM□-B12**

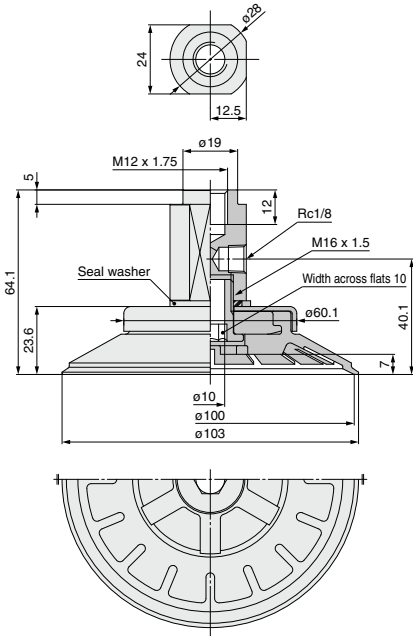

**Weights** [g]

Model	Pad material			
		N/U/CL	S	F
ZP3E-Y100UM□-B12		271	267	297

**ZP3E-Y125UM□-B12**

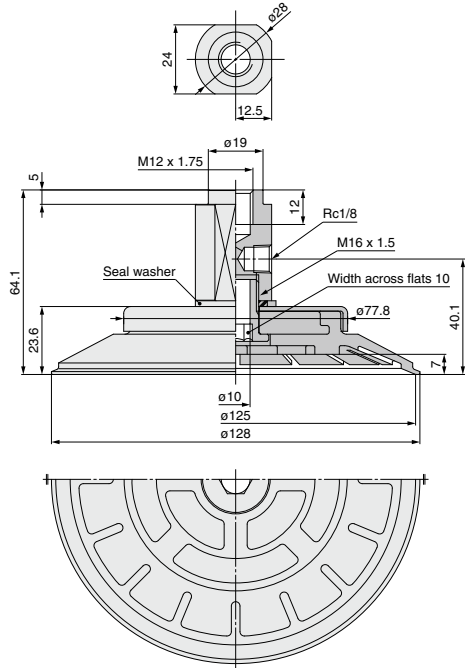

**Weights** [g]

Model	Pad material			
		N/U/CL	S	F
ZP3E-Y125UM□-B12		364	357	411

ZP3

ZP3E

ZP2

ZP2V

ZP

ZPT

ZPR

XT661

# ZP3E Series

Dimensions/With Male Thread Adapter: Vacuum Inlet

Lateral

Pad diameter  $\phi 32$  to  $\phi 80$

Pad form Bellows type with groove



## ZP3E-Y32BM□-AL14

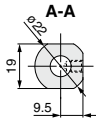
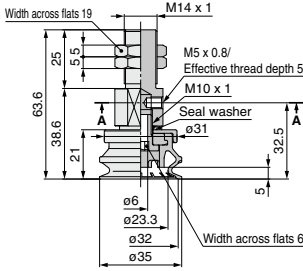

## ZP3E-Y40BM□-AL14

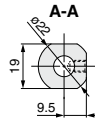
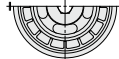
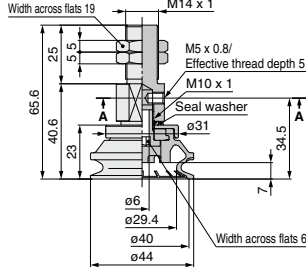

## ZP3E-Y50BM□-AL14

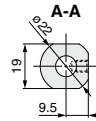
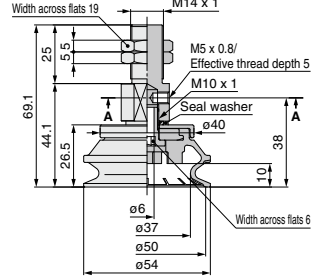

### Weights [g]

Model	Pad material	N/U/CL	S	F
ZP3E-Y32BM□-AL14		60.4	59.9	64.0

### Weights [g]

Model	Pad material	N/U/CL	S	F
ZP3E-Y40BM□-AL14		64.4	63.5	70.4

### Weights [g]

Model	Pad material	N/U/CL	S	F
ZP3E-Y50BM□-AL14		78.5	77.0	89.0

## ZP3E-Y63BM□-AL16

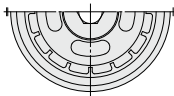
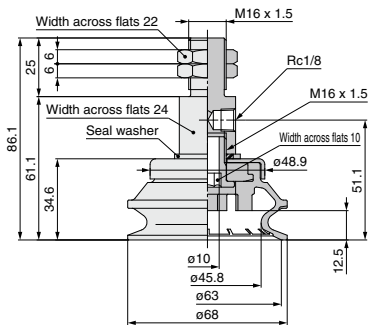

## ZP3E-Y80BM□-AL16

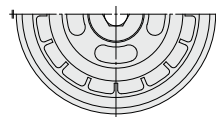
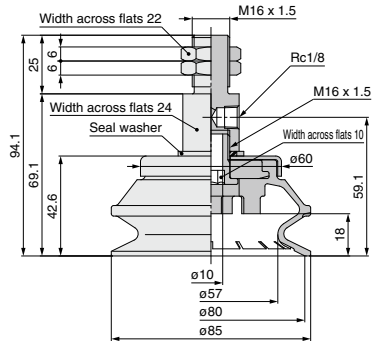

### Weights [g]

Model	Pad material	N/U/CL	S	F
ZP3E-Y63BM□-AL16		233	230	253

### Weights [g]

Model	Pad material	N/U/CL	S	F
ZP3E-Y80BM□-AL16		286	281	322



**Dimensions/With Male Thread Adapter: Vacuum Inlet**

Lateral

**Pad diameter**  $\phi 100, \phi 125$

**Pad form** Bellows type with groove



**ZP3E-Y100BM□-AL16**

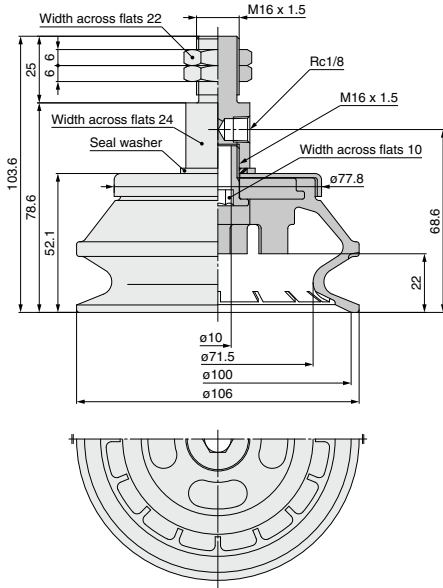

**ZP3E-Y125BM□-AL16**

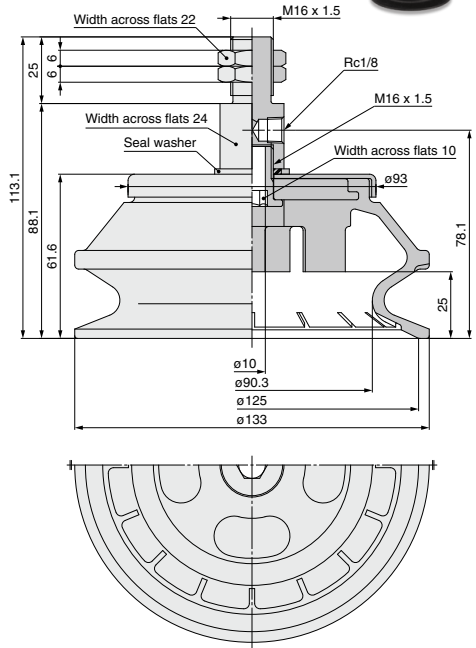

**Weights** [g]

Model	Pad material	N/U/CL	S	F
ZP3E-Y100BM□-AL16		410	399	482

**Weights** [g]

Model	Pad material	N/U/CL	S	F
ZP3E-Y125BM□-AL16		582	563	719

ZP3

ZP3E

ZP2

ZP2V

ZP

ZPT

ZPR

XT661

# ZP3E Series

Dimensions/With Female Thread Adapter: Vacuum Inlet

Lateral

Pad diameter  $\phi 32$  to  $\phi 80$

Pad form Bellows type with groove



ZP3E-Y32BM□-B8

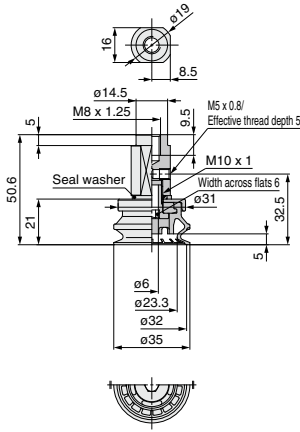

ZP3E-Y40BM□-B8

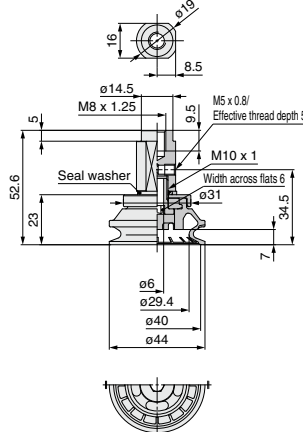

ZP3E-Y50BM□-B8

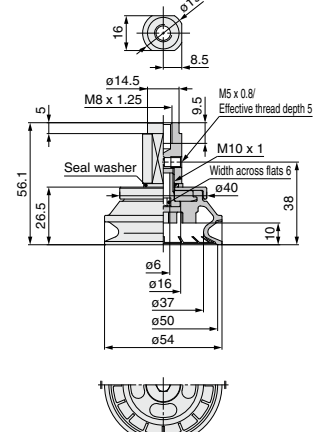

**Weights**

Model	Pad material		
	N/U/CL	S	F
ZP3E-Y32BM□-B8	38.8	38.3	42.4

**Weights**

Model	Pad material		
	N/U/CL	S	F
ZP3E-Y40BM□-B8	42.8	41.9	48.8

**Weights**

Model	Pad material		
	N/U/CL	S	F
ZP3E-Y50BM□-B8	56.9	55.4	67.4

ZP3E-Y63BM□-B12

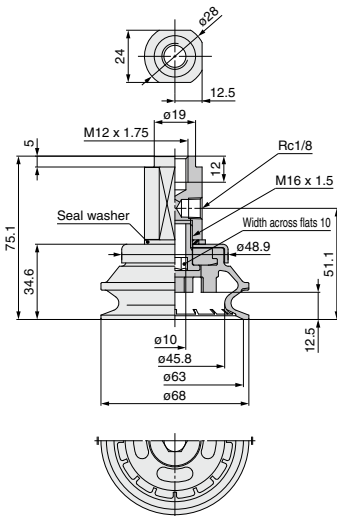

ZP3E-Y80BM□-B12

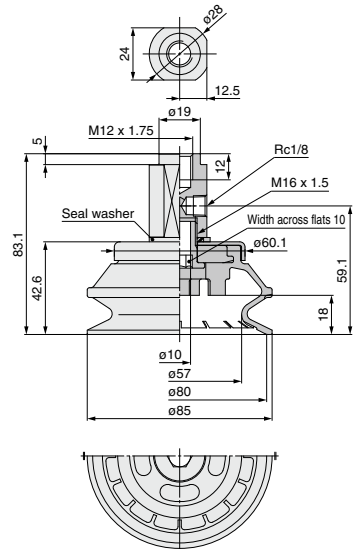

**Weights**

Model	Pad material		
	N/U/CL	S	F
ZP3E-Y63BM□-B12	159	156	179

**Weights**

Model	Pad material		
	N/U/CL	S	F
ZP3E-Y80BM□-B12	212	207	247

Dimensions/With Female Thread Adapter: Vacuum Inlet Lateral

Pad diameter  $\phi 100, \phi 125$   
 Pad form Bellows type with groove



**ZP3E-Y100BM□-B12**

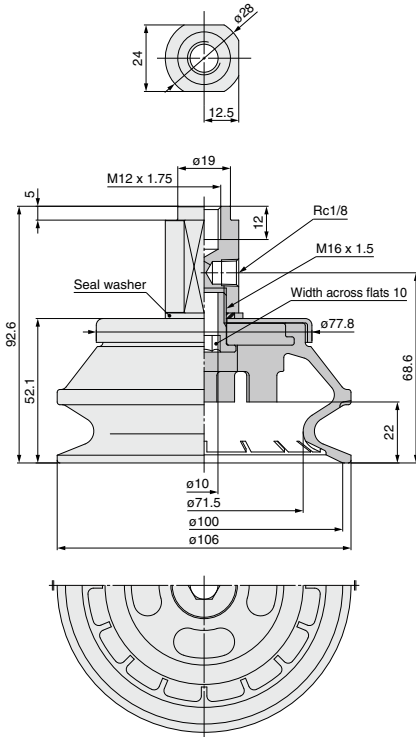

**Weights**

Model	Pad material		
	N/U/CL	S	F
ZP3E-Y100BM□-B12	335	324	407

**ZP3E-Y125BM□-B12**

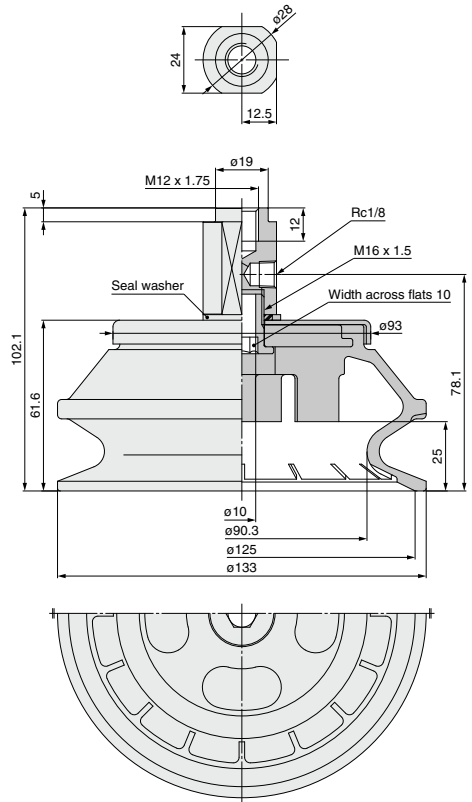

**Weights**

Model	Pad material		
	N/U/CL	S	F
ZP3E-Y125BM□-B12	508	489	645

ZP3

ZP3E

ZP2

ZP2V

ZP

ZPT

ZPR

XT661

## How to Order

### With buffer ZP3E - T 32 UM N JB 10

• Vacuum inlet direction

Symbol	Direction
T	Vertical

• Pad diameter

Symbol	Pad diameter
32	ø32
40	ø40
50	ø50
63	ø63
80	ø80
100	ø100
125	ø125

• Stroke (■)

Symbol	Stroke
10	10 mm
30	30 mm
50	50 mm

• Buffer specification

JB	Rotating, With bushing
----	------------------------

• Pad form

Symbol	Form
UM	Flat type with groove
BM	Belows type with groove

• Pad material

Symbol	Material
N	NBR
S	Silicone rubber
U	Urethane rubber
F	FKM
CL	Mark-free NBR

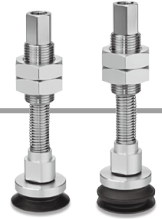

\* Refer to page 474 for replacement parts.

## Specifications

Buffer specification	Pad diameter	Mounting	Tightening torque [N·m]	Stroke [mm]	Spring reactive force [N]	
					At 0 stroke	At full stroke
Rotating	ø32 to ø50	M18 x 1.5	28 to 32	10	5	6.5
				30	5	8.5
				50	5	10.5
	ø63 to ø125	M22 x 1.5	48 to 52	10	10	11.5
				30	10	13.5
				50	10	15.5

## Dimensions/With Buffer: Vacuum Inlet

Vertical

Pad diameter ø32 to ø50

Pad form Flat type with groove

### ZP3E-T32UM□JB■

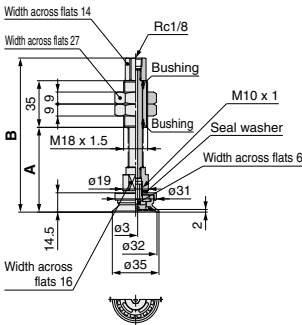

### ZP3E-T40UM□JB■

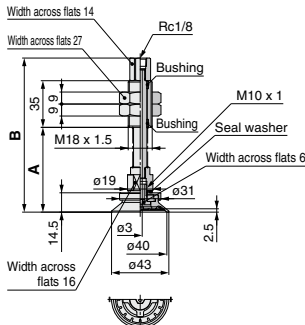

### ZP3E-T50UM□JB■

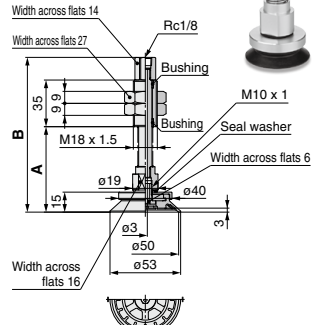

## Dimensions

Model	A	B
ZP3E-T32UM□JB10	63.6	115.6
ZP3E-T32UM□JB30	88.6	140.6
ZP3E-T32UM□JB50	108.6	160.6

Model	Weight [g]/Pad material		
	N/U/CL	S	F
ZP3E-T32UM□JB10	194	194	197
ZP3E-T32UM□JB30	209	208	211
ZP3E-T32UM□JB50	220	220	223

## Dimensions

Model	A	B
ZP3E-T40UM□JB10	63.6	115.6
ZP3E-T40UM□JB30	88.6	140.6
ZP3E-T40UM□JB50	108.6	160.6

Model	Weight [g]/Pad material		
	N/U/CL	S	F
ZP3E-T40UM□JB10	195	195	198
ZP3E-T40UM□JB30	210	209	213
ZP3E-T40UM□JB50	221	221	224

## Dimensions

Model	A	B
ZP3E-T50UM□JB10	64.1	116.1
ZP3E-T50UM□JB30	89.1	141.1
ZP3E-T50UM□JB50	109.1	161.1

Model	Weight [g]/Pad material		
	N/U/CL	S	F
ZP3E-T50UM□JB10	206	205	211
ZP3E-T50UM□JB30	220	220	226
ZP3E-T50UM□JB50	232	231	237



# ZP3E Series

Dimensions/With Buffer: Vacuum Inlet



Pad diameter  $\phi 32$  to  $\phi 63$

Pad form Bellows type with groove



## ZP3E-T32BM□JB■

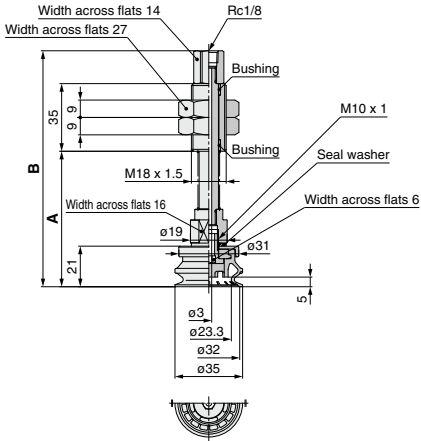

## ZP3E-T40BM□JB■

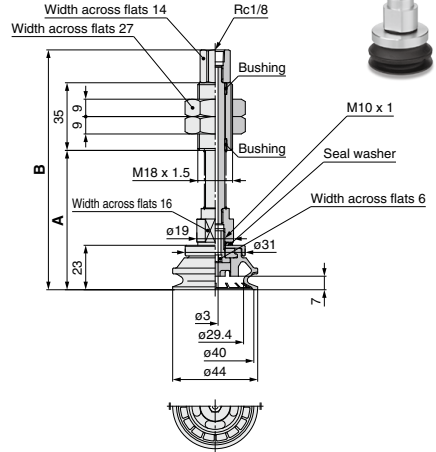

### Dimensions

Model	A	B	Weight (g)/Pad material		
			N/U/CL	S	F
ZP3E-T32BM□JB10	70.1	122.1	204	204	207
ZP3E-T32BM□JB30	95.1	147.1	219	218	221
ZP3E-T32BM□JB50	115.1	167.1	230	230	233

### Dimensions

Model	A	B	Weight (g)/Pad material		
			N/U/CL	S	F
ZP3E-T40BM□JB10	72.1	124.1	205	205	208
ZP3E-T40BM□JB30	97.1	149.1	220	219	223
ZP3E-T40BM□JB50	117.1	169.1	231	231	234

## ZP3E-T50BM□JB■

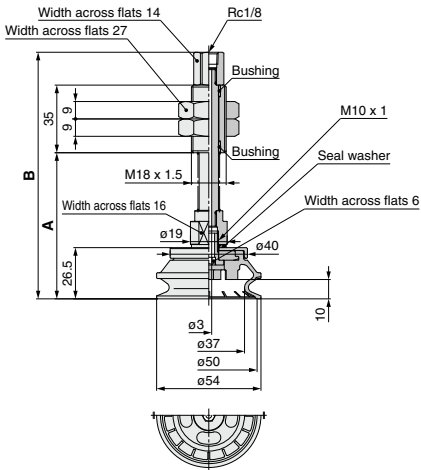

## ZP3E-T63BM□JB■

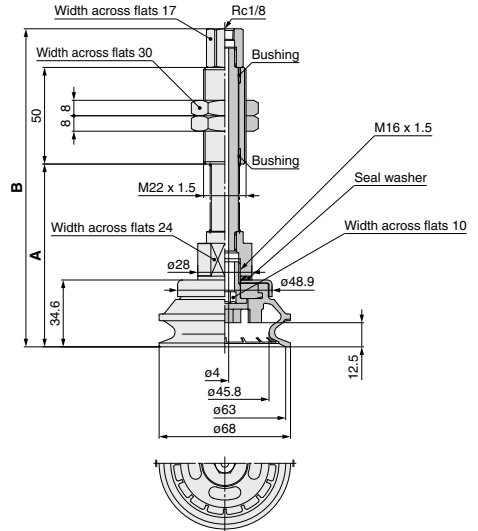

### Dimensions

Model	A	B	Weight (g)/Pad material		
			N/U/CL	S	F
ZP3E-T50BM□JB10	75.6	127.6	223	222	229
ZP3E-T50BM□JB30	100.6	152.6	238	237	243
ZP3E-T50BM□JB50	120.6	172.6	249	249	255

### Dimensions

Model	A	B	Weight (g)/Pad material		
			N/U/CL	S	F
ZP3E-T63BM□JB10	94.6	164.6	434	433	445
ZP3E-T63BM□JB30	119.6	189.6	464	462	474
ZP3E-T63BM□JB50	139.6	209.6	487	485	497

**Dimensions/With Buffer: Vacuum Inlet** 

Pad diameter  $\phi 80$  to  $\phi 125$

Pad form Bellows type with groove



**ZP3E-T80BM□JB■**

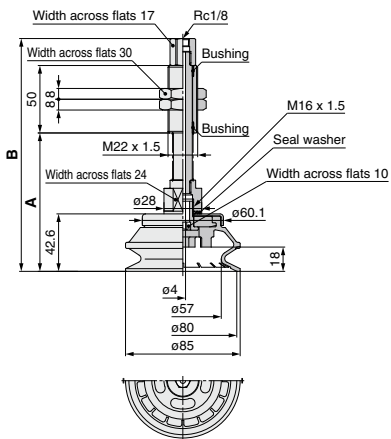

**ZP3E-T100BM□JB■**

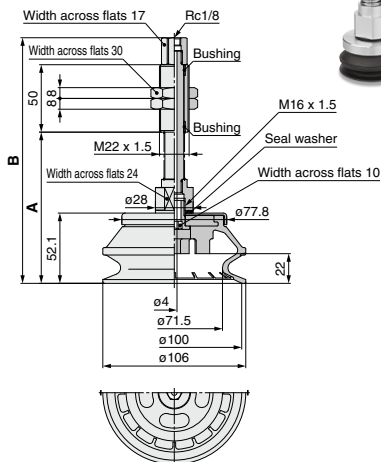

**Dimensions**

Model	A	B	Weight [g]/Pad material		
			N/U/CL	S	F
ZP3E-T80BM□JB10	102.6	172.6	443	441	458
ZP3E-T80BM□JB30	127.6	197.6	472	470	487
ZP3E-T80BM□JB50	147.6	217.6	495	493	510

**Dimensions**

Model	A	B	Weight [g]/Pad material		
			N/U/CL	S	F
ZP3E-T100BM□JB10	112.1	182.1	481	477	507
ZP3E-T100BM□JB30	137.1	207.1	510	506	536
ZP3E-T100BM□JB50	157.1	227.1	533	529	559

**ZP3E-T125BM□JB■**

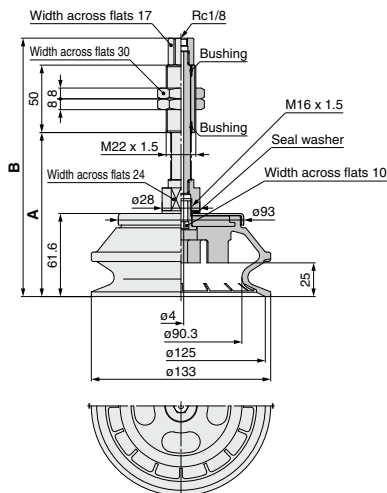

**Dimensions**

Model	A	B	Weight [g]/Pad material		
			N/U/CL	S	F
ZP3E-T125BM□JB10	121.6	191.6	558	552	605
ZP3E-T125BM□JB30	146.6	216.6	588	581	634
ZP3E-T125BM□JB50	166.6	236.6	610	604	657

ZP3

ZP3E

ZP2

ZP2V

ZP

ZPT

ZPR

XT661

# ZP3E Series

## How to Order

With buffer **ZP3E - Y 32 UM N JB 10**

Vacuum inlet direction

Symbol	Direction
Y	Lateral

Pad diameter

Symbol	Pad diameter
32	ø32
40	ø40
50	ø50
63	ø63
80	ø80
100	ø100
125	ø125

Pad form

Symbol	Form
UM	Flat type with groove
BM	Bel lows type with groove

Pad material

Symbol	Material
N	NBR
S	Silicone rubber
U	Urethane rubber
F	FKM
CL	Mark-free NBR

Stroke (■)

Symbol	Stroke
10	10 mm
30	30 mm
50	50 mm

Buffer specification

JB	Rotating, With bushing
----	------------------------



\* Refer to page 474 for replacement parts.

## Specifications

Buffer specification	Pad diameter	Mounting	Tightening torque [N·m]	Stroke [mm]	Spring reactive force [N]	
					At 0 stroke	At full stroke
Rotating	ø32 to ø50	M18 x 1.5	28 to 32	10	5	6.5
				30	5	8.5
				50	5	10.5
	ø63 to ø125	M22 x 1.5	48 to 52	10	10	11.5
				30	10	13.5
				50	10	15.5

## Dimensions/With Buffer: Vacuum Inlet

Lateral

Pad diameter ø32 to ø50

Pad form Flat type with groove

### ZP3E-Y32UM□JB■

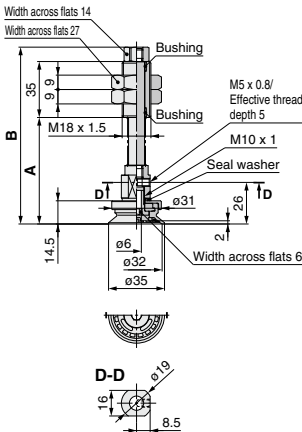

### ZP3E-Y40UM□JB■

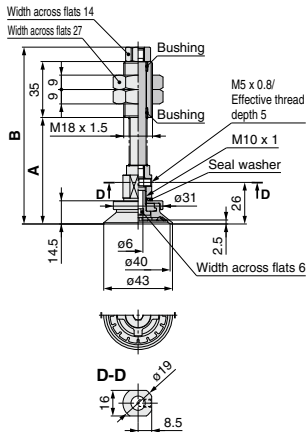

### ZP3E-Y50UM□JB■

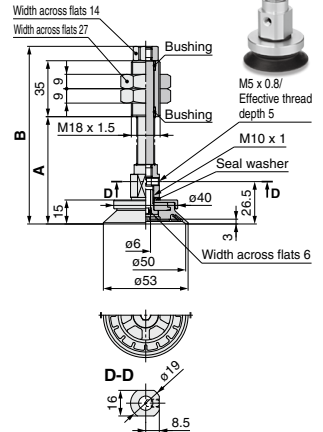

#### Dimensions

Model	A	B
ZP3E-Y32UM□JB10	66.6	110.6
ZP3E-Y32UM□JB30	91.6	135.6
ZP3E-Y32UM□JB50	111.6	155.6

#### Dimensions

Model	A	B
ZP3E-Y40UM□JB10	66.6	110.6
ZP3E-Y40UM□JB30	91.6	135.6
ZP3E-Y40UM□JB50	111.6	155.6

#### Dimensions

Model	A	B
ZP3E-Y50UM□JB10	67.1	111.1
ZP3E-Y50UM□JB30	92.1	136.1
ZP3E-Y50UM□JB50	112.1	156.1

Model	Weight [g]/Pad material		
	N/U/CL	S	F
ZP3E-Y32UM□JB10	196	196	200
ZP3E-Y32UM□JB30	211	210	214
ZP3E-Y32UM□JB50	222	222	226

Model	Weight [g]/Pad material		
	N/U/CL	S	F
ZP3E-Y40UM□JB10	200	199	206
ZP3E-Y40UM□JB30	215	214	221
ZP3E-Y40UM□JB50	226	225	232

Model	Weight [g]/Pad material		
	N/U/CL	S	F
ZP3E-Y50UM□JB10	214	213	225
ZP3E-Y50UM□JB30	229	227	239
ZP3E-Y50UM□JB50	240	239	251





**Dimensions/With Buffer: Vacuum Inlet** Lateral

**Pad diameter**  $\phi 63$  to  $\phi 125$

**Pad form** Flat type with groove

**ZP3E-Y63UM□JB■**

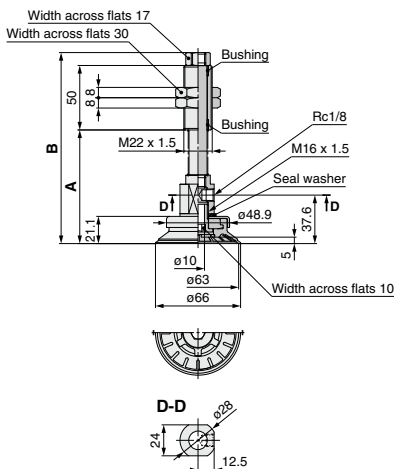

**ZP3E-Y80UM□JB■**

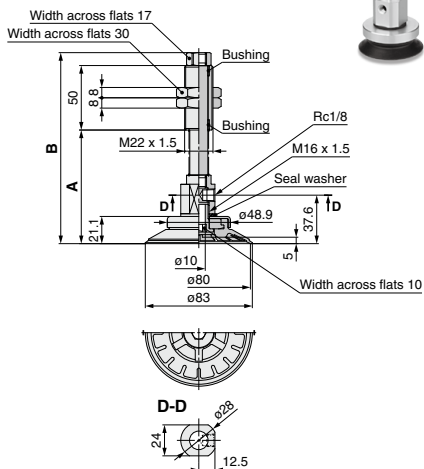

**Dimensions**

Model	A	B	Weight (g)/Pad material		
			N/U/CL	S	F
ZP3E-Y63UM□JB10	88.1	148.1	424	421	445
ZP3E-Y63UM□JB30	113.1	173.1	453	451	474
ZP3E-Y63UM□JB50	133.1	193.1	476	473	497

**Dimensions**

Model	A	B	Weight (g)/Pad material		
			N/U/CL	S	F
ZP3E-Y80UM□JB10	88.1	148.1	478	473	513
ZP3E-Y80UM□JB30	113.1	173.1	507	502	542
ZP3E-Y80UM□JB50	133.1	193.1	530	525	565

**ZP3E-Y100UM□JB■**

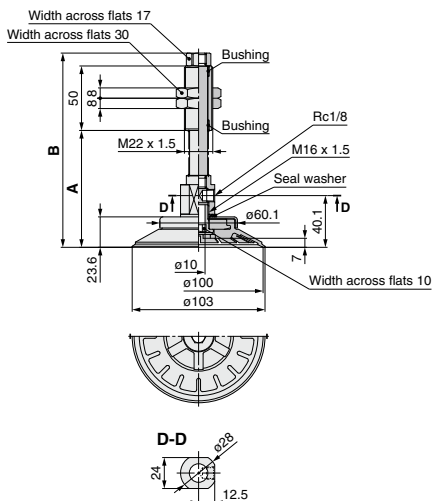

**ZP3E-Y125UM□JB■**

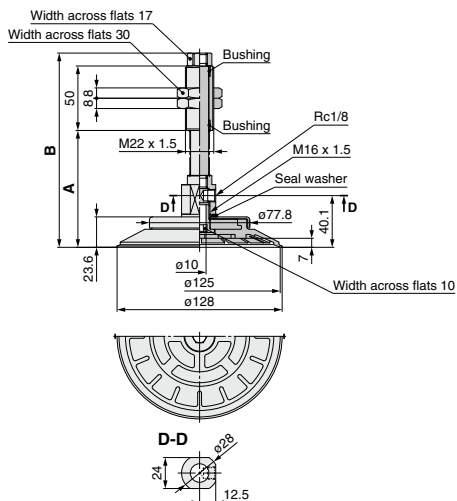

**Dimensions**

Model	A	B	Weight (g)/Pad material		
			N/U/CL	S	F
ZP3E-Y100UM□JB10	90.6	150.6	601	590	673
ZP3E-Y100UM□JB30	115.6	175.6	630	619	702
ZP3E-Y100UM□JB50	135.6	195.6	653	642	725

**Dimensions**

Model	A	B	Weight (g)/Pad material		
			N/U/CL	S	F
ZP3E-Y125UM□JB10	90.6	150.6	773	754	910
ZP3E-Y125UM□JB30	115.6	175.6	803	784	940
ZP3E-Y125UM□JB50	135.6	195.6	826	807	963

ZP3

ZP3E

ZP2

ZP2V

ZP

ZPT

ZPR

XT661

# ZP3E Series

Dimensions/With Buffer: Vacuum Inlet Lateral

Pad diameter  $\phi 32$  to  $\phi 63$

Pad form Bellows type with groove



## ZP3E-Y32BM□JB■

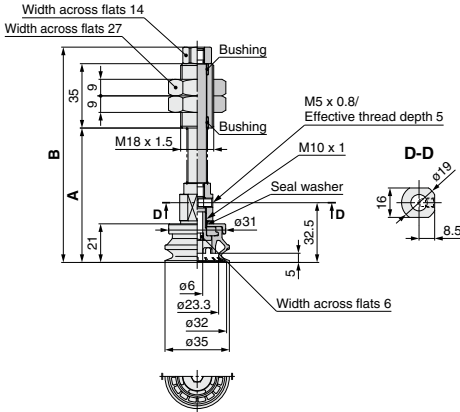

## ZP3E-Y40BM□JB■

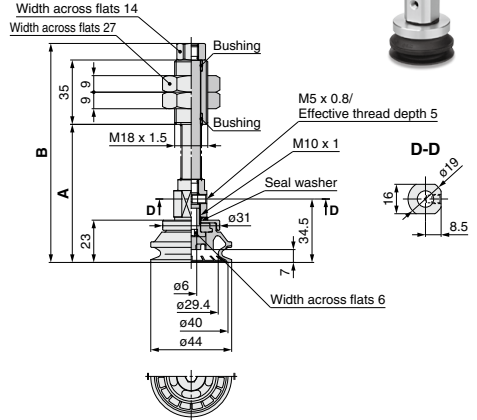

### Dimensions

Model	A	B	Weight [g]/Pad material		
			N/U/CL	S	F
ZP3E-Y32BM□JB10	73.1	117.1	194	194	198
ZP3E-Y32BM□JB30	98.1	142.1	210	210	214
ZP3E-Y32BM□JB50	118.1	162.1	223	223	227

### Dimensions

Model	A	B	Weight [g]/Pad material		
			N/U/CL	S	F
ZP3E-Y40BM□JB10	75.1	119.1	198	197	206
ZP3E-Y40BM□JB30	100.1	144.1	214	213	220
ZP3E-Y40BM□JB50	120.1	164.1	227	226	233

## ZP3E-Y50BM□JB■

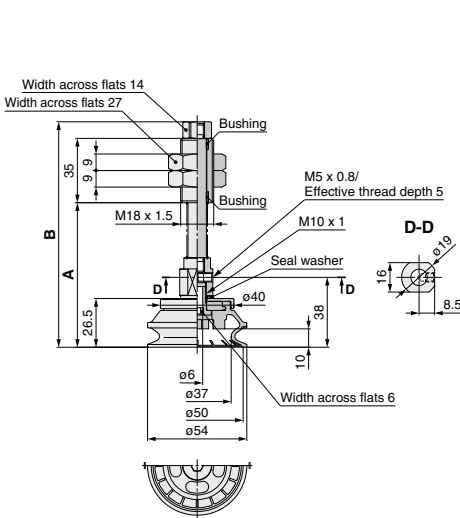

## ZP3E-Y63BM□JB■

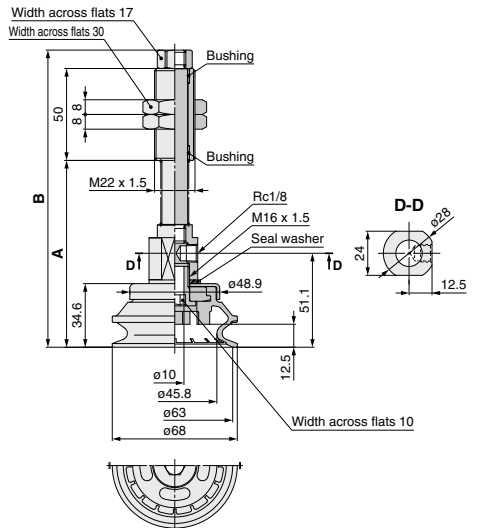

### Dimensions

Model	A	B	Weight [g]/Pad material		
			N/U/CL	S	F
ZP3E-Y50BM□JB10	78.6	122.6	212	211	223
ZP3E-Y50BM□JB30	103.6	147.6	228	227	239
ZP3E-Y50BM□JB50	123.6	167.6	241	240	252

### Dimensions

Model	A	B	Weight [g]/Pad material		
			N/U/CL	S	F
ZP3E-Y63BM□JB10	101.6	161.6	422	419	442
ZP3E-Y63BM□JB30	126.6	186.6	453	450	474
ZP3E-Y63BM□JB50	146.6	206.6	478	475	499



# ZP3E Series

## How to Order



Vertical vacuum inlet  
With ball joint adapter

## ZP3E - T F 32 UM N - AL6

### Vacuum inlet direction

Symbol	Direction
T	Vertical

### Specification (mechanism)

Symbol	Specification
F	Ball joint

### Pad diameter

Symbol	Pad diameter
32	ø32
40	ø40
50	ø50
63	ø63
80	ø80
100	ø100
125	ø125

### Pad form

Symbol	Form
UM	Flat type with groove
BM	Bellows type with groove

### Mounting thread size

	Symbol	Mounting Thread size	ø32	ø63	
			to ø50	to ø125	
Male thread	For direct mounting	AL6	M6 x 1	●	—
	For plate connection	AL12	M12 x 1.25	—	●
		AL14	M14 x 1	—	—
Female thread	B8	M8 x 1.25	●	—	
	B12	M12 x 1.75	—	●	

### Pad material

Symbol	Material
N	NBR
S	Silicone rubber
U	Urethane rubber
F	FKM
CL	Mark-free NBR

\* Refer to pages 475 and 476 for replacement parts.

## Dimensions/With Ball Joint Adapter: Vacuum Inlet

Vertical

Pad diameter ø32, ø40

Pad form Flat type with groove



### ZP3E-TF32UM□-AL6

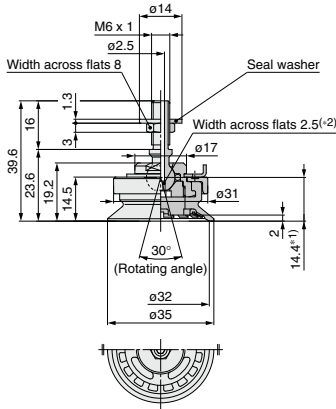

### ZP3E-TF40UM□-AL6

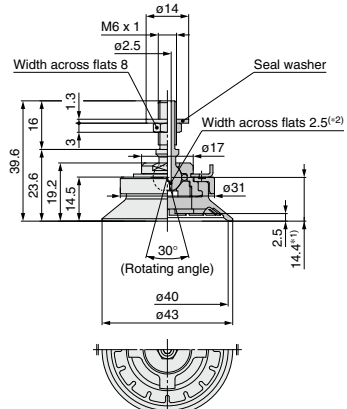

### Weights

[g]

Model	Pad material		
	N/U/CL	S	F
ZP3E-TF32UM□-AL6	38.0	37.7	40.5

### Weights

[g]

Model	Pad material		
	N/U/CL	S	F
ZP3E-TF40UM□-AL6	39.1	38.6	42.2

\*1) Center of the rotating angle

\*2) Position of the adapter mounting tool

Note) When mounting and removing this product, use a hexagon wrench at the position of the adapter mounting tool shown in the figure (\*2).

**Dimensions/With Ball Joint Adapter: Vacuum Inlet**

**Pad diameter**  $\phi 50$  to  $\phi 100$   
**Pad form** Flat type with groove



**ZP3E-TF50UM□-AL6**

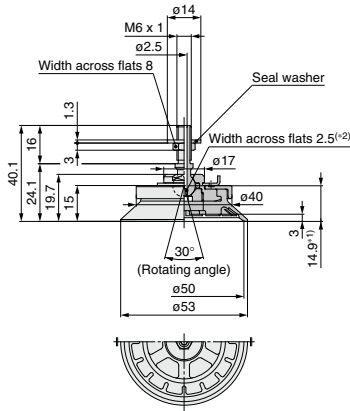

Weights		[g]		
Model	Pad material	N/U/CL	S	F
ZP3E-TF50UM□-AL6		57.2	56.4	62.2

**ZP3E-TF63UM□-AL12**

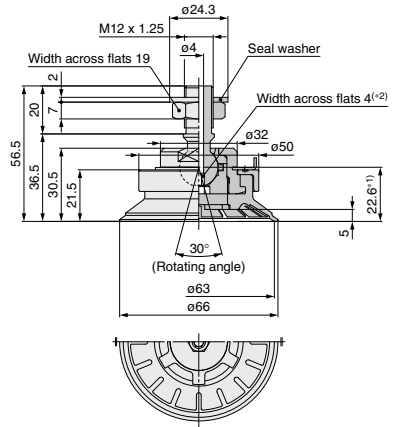

Weights		[g]		
Model	Pad material	N/U/CL	S	F
ZP3E-TF63UM□-AL12		146	145	157

**ZP3E-TF80UM□-AL12**

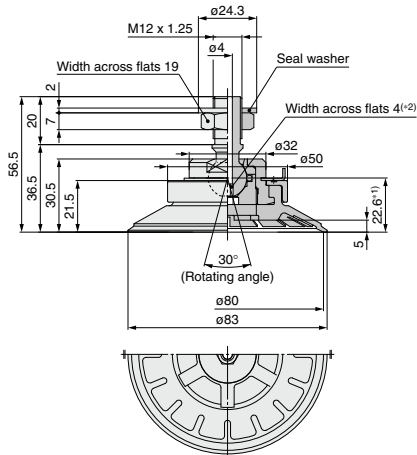

Weights		[g]		
Model	Pad material	N/U/CL	S	F
ZP3E-TF80UM□-AL12		154	152	170

**ZP3E-TF100UM□-AL12**

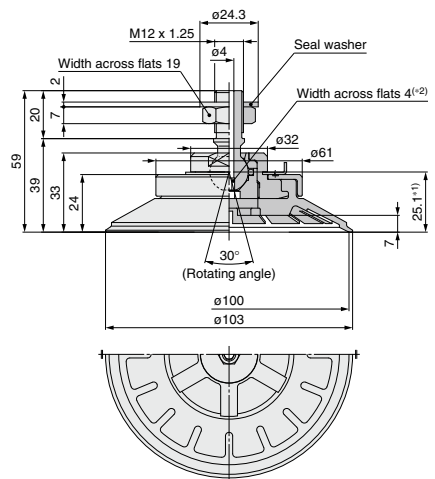

Weights		[g]		
Model	Pad material	N/U/CL	S	F
ZP3E-TF100UM□-AL12		192	189	218

ZP3  
 ZP3E  
 ZP2  
 ZP2V  
 ZP  
 ZPT  
 ZPR  
 XT661

\*1) Center of the rotating angle  
 \*2) Position of the adapter mounting tool

Note) When mounting and removing this product, use a hexagon wrench at the position of the adapter mounting tool shown in the figure (\*2).

# ZP3E Series

Dimensions/With Ball Joint Adapter: Vacuum Inlet

Vertical

Pad diameter  $\phi 125$

Pad form Flat type with groove



## ZP3E-TF125UM□-AL12

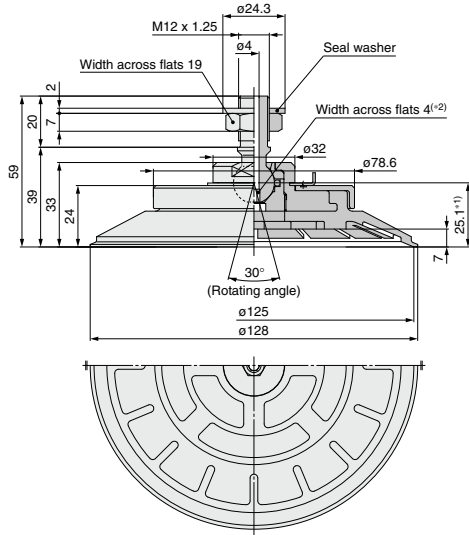

### Weights

Model	Pad material	[g]		
		N/U/CL	S	F
ZP3E-TF125UM□-AL12		270	263	317

\*1) Center of the rotating angle

\*2) Position of the adapter mounting tool

Note) When mounting and removing this product, use a hexagon wrench at the position of the adapter mounting tool shown in the figure (\*2).



Dimensions/With Ball Joint Male Thread Adapter: Vacuum Inlet **Vertical**

Pad diameter  $\phi 32$  to  $\phi 63$

Pad form Flat type with groove

**ZP3E-TF32UM-AL14**

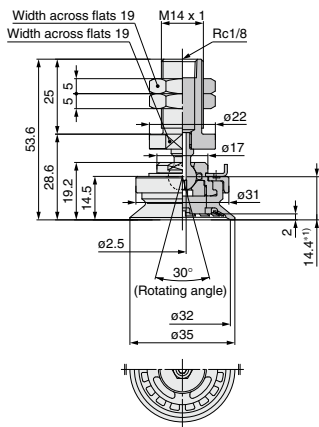

**ZP3E-TF40UM-AL14**

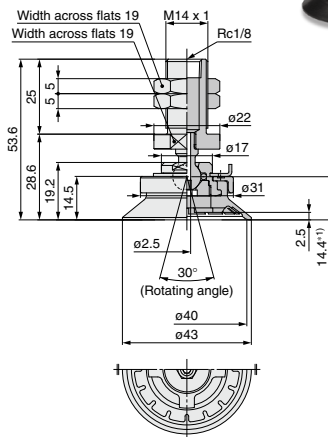

**Weights**

Model	Pad material		
	N/U/CL	S	F
ZP3E-TF32UM-AL14	59.0	58.6	61.4

**Weights**

Model	Pad material		
	N/U/CL	S	F
ZP3E-TF40UM-AL14	60.0	59.6	63.1

**ZP3E-TF50UM-AL14**

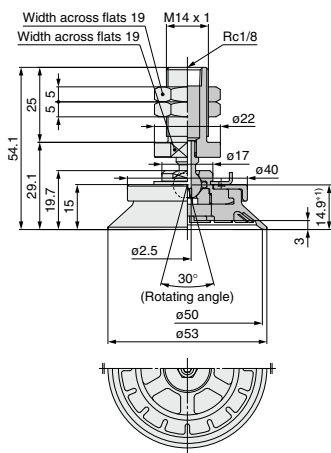

**ZP3E-TF63UM-AL16**

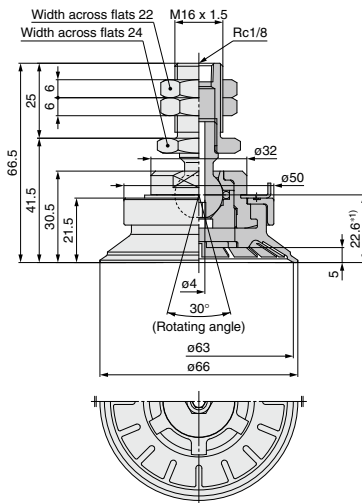

**Weights**

Model	Pad material		
	N/U/CL	S	F
ZP3E-TF50UM-AL14	78.1	77.3	83.6

**Weights**

Model	Pad material		
	N/U/CL	S	F
ZP3E-TF63UM-AL16	184	183	195

ZP3

ZP3E

ZP2

ZP2V

ZP

ZPT

ZPR

XT661

\*1) Center of the rotating angle

# ZP3E Series

Dimensions/With Ball Joint Male Thread Adapter: Vacuum Inlet

Vertical

Pad diameter  $\phi 80$  to  $\phi 125$

Pad form Flat type with groove



## ZP3E-TF80UM□-AL16

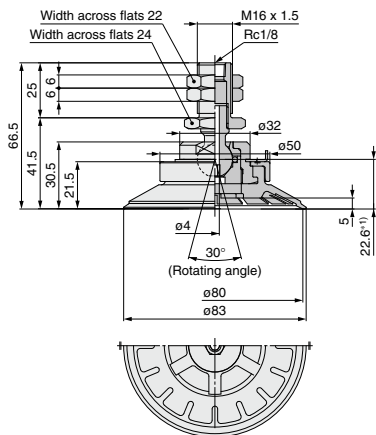

### Weights

[g]

Model	Pad material	N/U/CL	S	F
ZP3E-TF80UM□-AL16		192	190	208

## ZP3E-TF100UM□-AL16

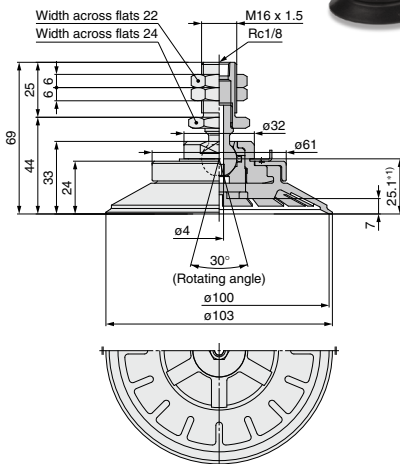

### Weights

[g]

Model	Pad material	N/U/CL	S	F
ZP3E-TF100UM□-AL16		230	227	256

## ZP3E-TF125UM□-AL16

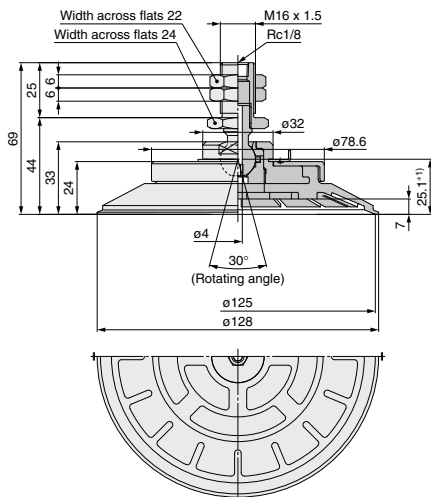

### Weights

[g]

Model	Pad material	N/U/CL	S	F
ZP3E-TF125UM□-AL16		308	301	355

\*1) Center of the rotating angle



Dimensions/With Ball Joint Female Thread Adapter: Vacuum Inlet

Vertical

Pad diameter  $\phi 32$  to  $\phi 63$

Pad form Flat type with groove



ZP3E-TF32UM□-B8

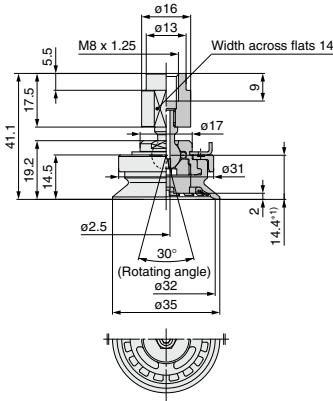

ZP3E-TF40UM□-B8

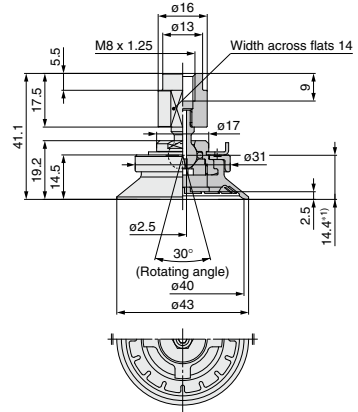

**Weights** [g]

Model	Pad material		
	N/U/CL	S	F
ZP3E-TF32UM□-B8	40.9	40.5	43.4

**Weights** [g]

Model	Pad material		
	N/U/CL	S	F
ZP3E-TF40UM□-B8	41.9	41.5	45.0

ZP3E-TF50UM□-B8

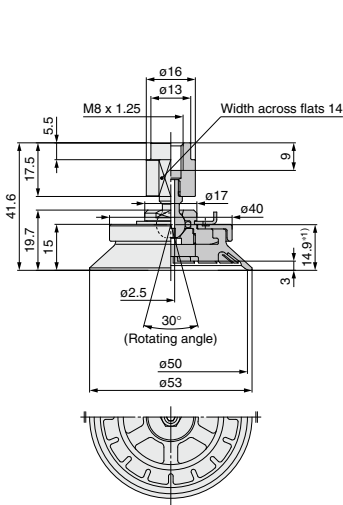

ZP3E-TF63UM□-B12

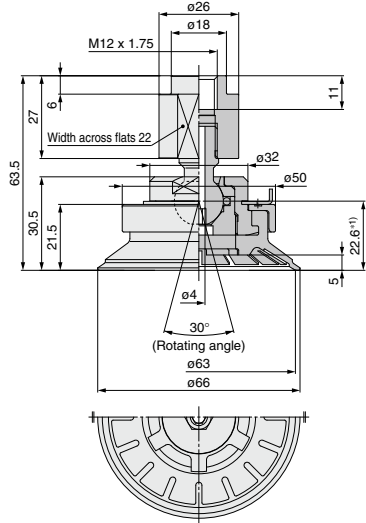

**Weights** [g]

Model	Pad material		
	N/U/CL	S	F
ZP3E-TF50UM□-B8	60.0	59.2	65.5

**Weights** [g]

Model	Pad material		
	N/U/CL	S	F
ZP3E-TF63UM□-B12	151	150	162

\*1) Center of the rotating angle

ZP3
ZP3E
ZP2
ZP2V
ZP
ZPT
ZPR
XT661

# ZP3E Series

Dimensions/With Ball Joint Female Thread Adapter: Vacuum Inlet

Vertical

Pad diameter  $\phi 80$  to  $\phi 125$

Pad form Flat type with groove



ZP3E-TF80UM□-B12

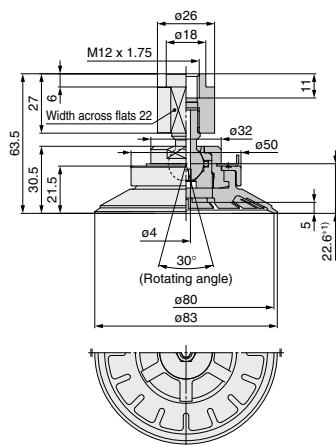

**Weights**

[g]

Model	Pad material	N/U/CL	S	F
ZP3E-TF80UM□-B12		160	157	175

ZP3E-TF100UM□-B12

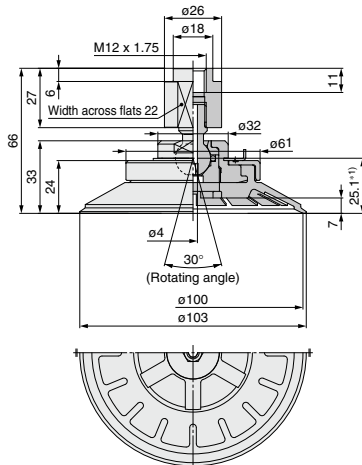

**Weights**

[g]

Model	Pad material	N/U/CL	S	F
ZP3E-TF100UM□-B12		198	194	224

ZP3E-TF125UM□-B12

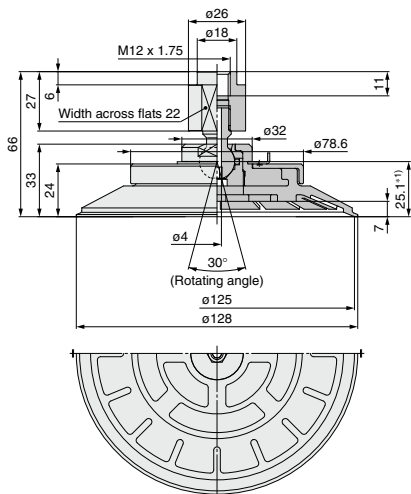

**Weights**

[g]

Model	Pad material	N/U/CL	S	F
ZP3E-TF125UM□-B12		275	269	322

\*1) Center of the rotating angle

Dimensions/With Ball Joint Adapter: Vacuum Inlet **Vertical**

Pad diameter  $\phi 32$  to  $\phi 63$

Pad form Bellows type with groove



**ZP3E-TF32BM□-AL6**

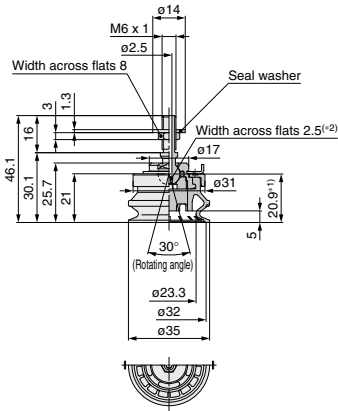

**Weights** [g]

Model	Pad material	N/U/CL	S	F
ZP3E-TF32BM□-AL6		40.0	39.5	43.6

**ZP3E-TF40BM□-AL6**

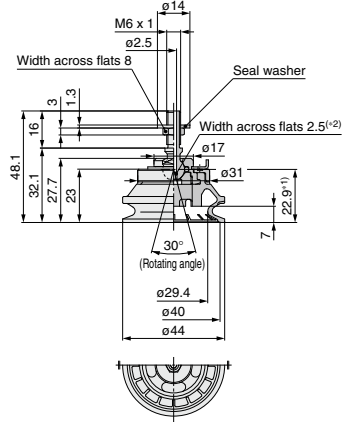

**Weights** [g]

Model	Pad material	N/U/CL	S	F
ZP3E-TF40BM□-AL6		44.0	43.1	50.0

**ZP3E-TF50BM□-AL6**

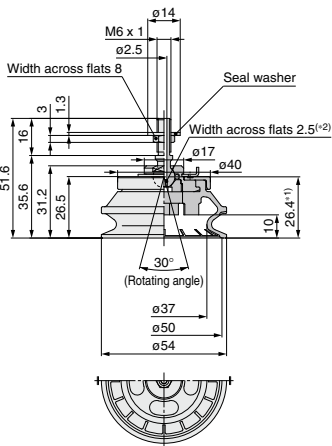

**Weights** [g]

Model	Pad material	N/U/CL	S	F
ZP3E-TF50BM□-AL6		65.6	64.1	76.1

**ZP3E-TF63BM□-AL12**

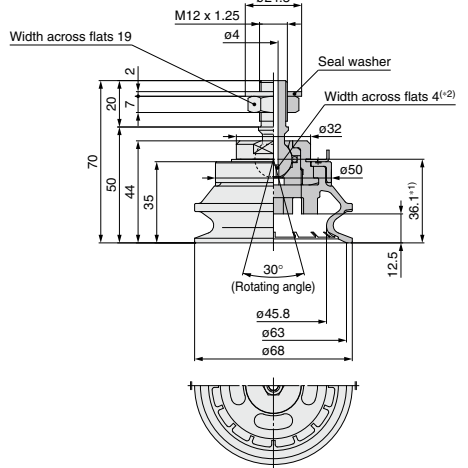

**Weights** [g]

Model	Pad material	N/U/CL	S	F
ZP3E-TF63BM□-AL12		163	160	183

ZP3

ZP3E

ZP2

ZP2V

ZP

ZPT

ZPR

XT661

\*1) Center of the rotating angle  
\*2) Position of the adapter mounting tool

Note) When mounting and removing this product, use a hexagon wrench at the position of the adapter mounting tool shown in the figure (\*2).

# ZP3E Series

Dimensions/With Ball Joint Adapter: Vacuum Inlet **Vertical**

Pad diameter  $\phi 80$  to  $\phi 125$

Pad form Bellows type with groove



ZP3E-TF80BM□-AL12

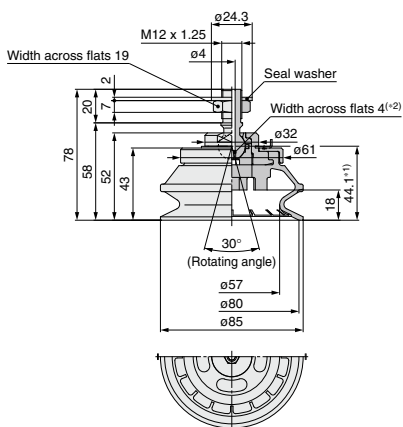

ZP3E-TF100BM□-AL12

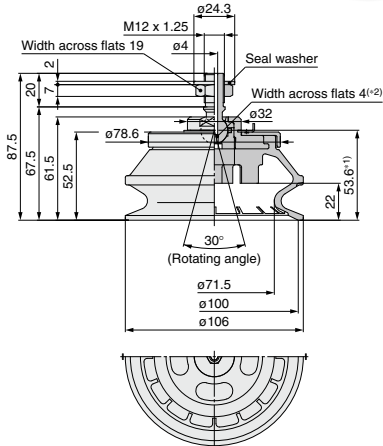

**Weights** [g]

Model	Pad material	N/U/CL	S	F
ZP3E-TF80BM□-AL12		208	203	243

**Weights** [g]

Model	Pad material	N/U/CL	S	F
ZP3E-TF100BM□-AL12		316	305	388

ZP3E-TF125BM□-AL12

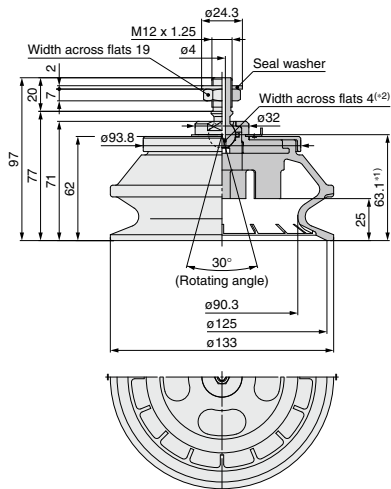

**Weights** [g]

Model	Pad material	N/U/CL	S	F
ZP3E-TF125BM□-AL12		473	454	610

\*1) Center of the rotating angle

\*2) Position of the adapter mounting tool

Note) When mounting and removing this product, use a hexagon wrench at the position of the adapter mounting tool shown in the figure (\*2).

Dimensions/With Ball Joint Male Thread Adapter: Vacuum Inlet **Vertical**

Pad diameter  $\phi 32$  to  $\phi 63$

Pad form Bellows type with groove



**ZP3E-TF32BM□-AL14**

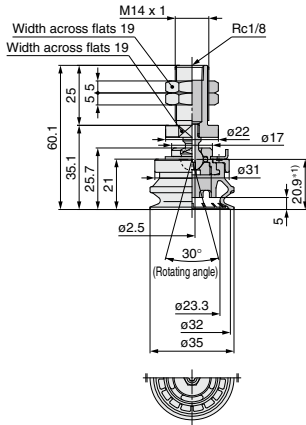

**ZP3E-TF40BM□-AL14**

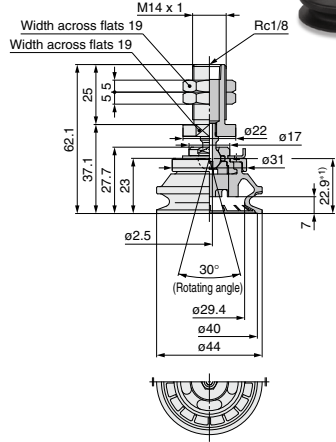

**Weights** [g]

Model	Pad material		
	N/U/CL	S	F
ZP3E-TF32BM□-AL14	60.9	60.4	64.6

**Weights** [g]

Model	Pad material		
	N/U/CL	S	F
ZP3E-TF40BM□-AL14	64.9	64.1	70.9

**ZP3E-TF50BM□-AL14**

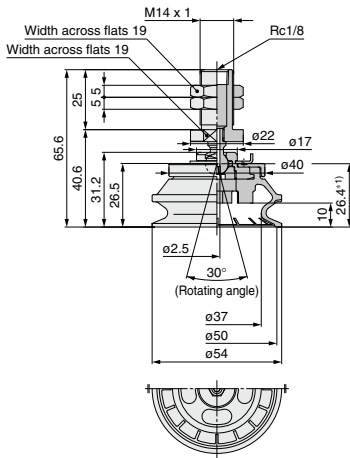

**ZP3E-TF63BM□-AL16**

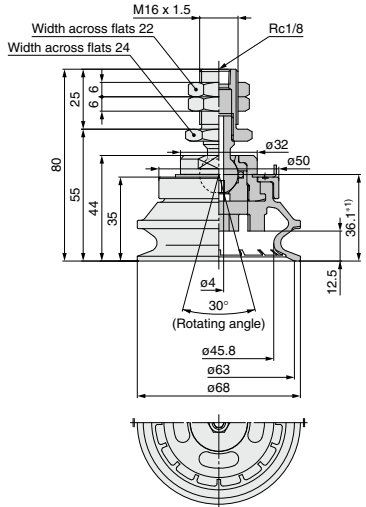

**Weights** [g]

Model	Pad material		
	N/U/CL	S	F
ZP3E-TF50BM□-AL14	86.6	85.1	97.1

**Weights** [g]

Model	Pad material		
	N/U/CL	S	F
ZP3E-TF63BM□-AL16	201	198	221

- ZP3
- ZP3E
- ZP2
- ZP2V
- ZP
- ZPT
- ZPR
- XT661

\*1) Center of the rotating angle

# ZP3E Series

Dimensions/With Ball Joint Male Thread Adapter: Vacuum Inlet

Vertical

Pad diameter  $\phi 80$  to  $\phi 125$

Pad form Bellows type with groove



ZP3E-TF80BM□-AL16

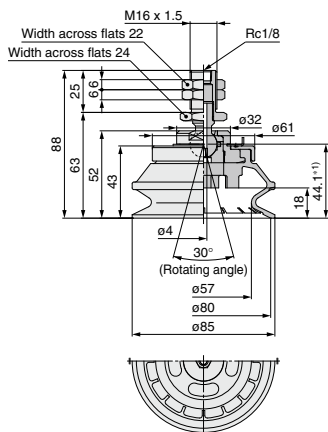

ZP3E-TF100BM□-AL16

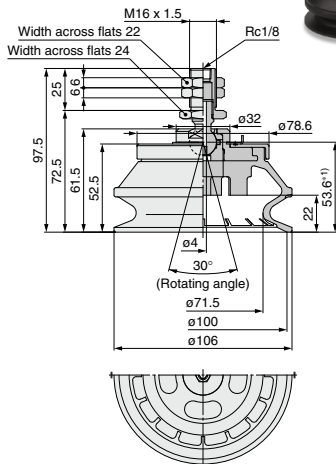

**Weights**

[g]

Model	Pad material	N/U/CL	S	F
ZP3E-TF80BM□-AL16		246	241	281

**Weights**

[g]

Model	Pad material	N/U/CL	S	F
ZP3E-TF100BM□-AL16		354	343	426

ZP3E-TF125BM□-AL16

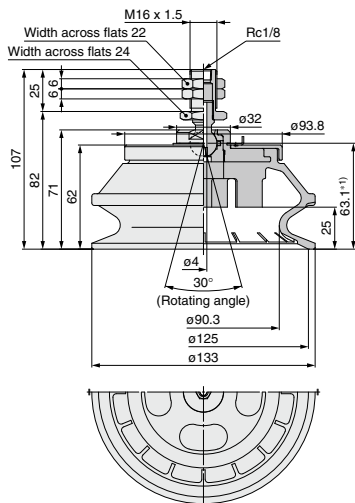

**Weights**

[g]

Model	Pad material	N/U/CL	S	F
ZP3E-TF125BM□-AL16		511	492	648

\*1) Center of the rotating angle

Dimensions/With Ball Joint Female Thread Adapter: Vacuum Inlet **Vertical**

Pad diameter  $\phi 32$  to  $\phi 63$

Pad form Bellows type with groove



**ZP3E-TF32BM□-B8**

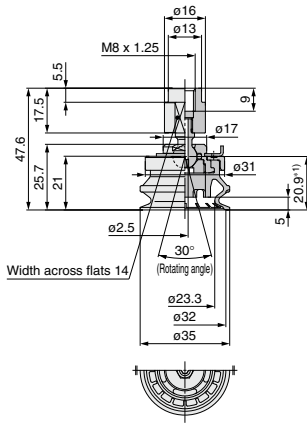

**Weights** [g]

Model	Pad material	N/U/CL	S	F
ZP3E-TF32BM□-B8		42.9	42.4	46.5

**ZP3E-TF40BM□-B8**

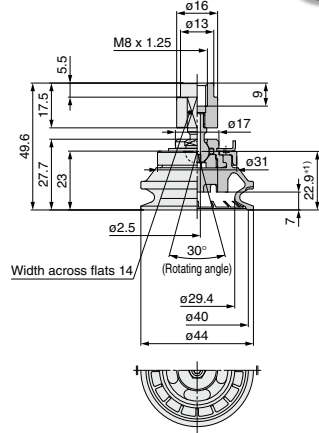

**Weights** [g]

Model	Pad material	N/U/CL	S	F
ZP3E-TF40BM□-B8		46.9	46.0	52.9

**ZP3E-TF50BM□-B8**

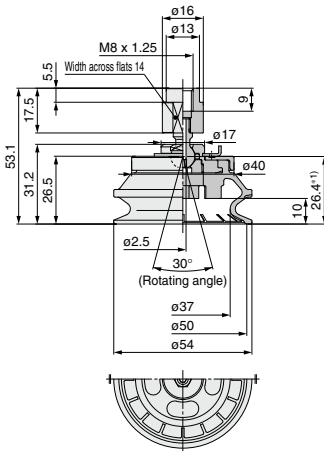

**Weights** [g]

Model	Pad material	N/U/CL	S	F
ZP3E-TF50BM□-B8		68.5	67.0	79.0

**ZP3E-TF63BM□-B12**

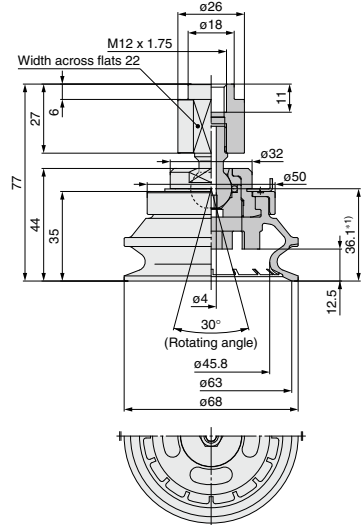

**Weights** [g]

Model	Pad material	N/U/CL	S	F
ZP3E-TF63BM□-B12		168	165	188

- ZP3
- ZP3E
- ZP2
- ZP2V
- ZP
- ZPT
- ZPR
- XT661

\*1) Center of the rotating angle

# ZP3E Series

Dimensions/With Ball Joint Female Thread Adapter: Vacuum Inlet

Vertical

Pad diameter  $\phi 80$  to  $\phi 125$

Pad form Bellows type with groove



ZP3E-TF80BM□-B12

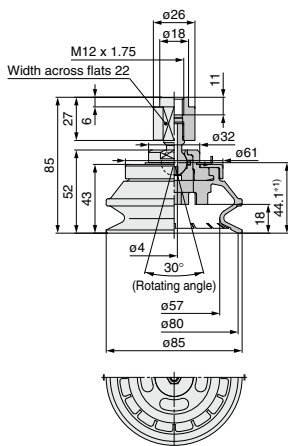

ZP3E-TF100BM□-B12

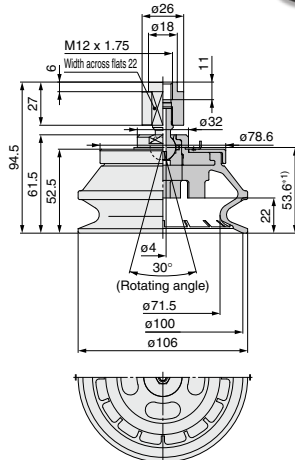

## Weights

[g]

Model	Pad material	N/U/CL	S	F
ZP3E-TF80BM□-B12		213	208	248

## Weights

[g]

Model	Pad material	N/U/CL	S	F
ZP3E-TF100BM□-B12		321	310	393

ZP3E-TF125BM□-B12

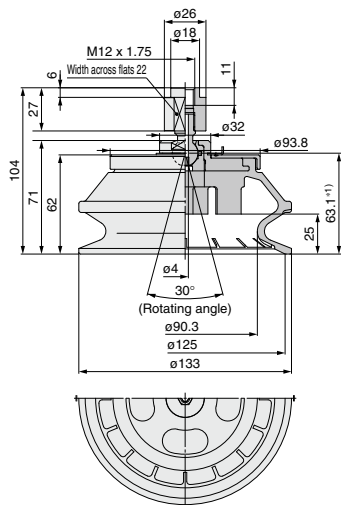

## Weights

[g]

Model	Pad material	N/U/CL	S	F
ZP3E-TF125BM□-B12		478	459	615

\*1) Center of the rotating angle



### How to Order



Lateral vacuum inlet  
With ball joint adapter

## ZP3E - Y F 32 UM N - AL14

**Vacuum inlet direction**

Symbol	Direction
Y	Lateral

**Specification (mechanism)**

Symbol	Specification
F	Ball joint

**Pad diameter**

Symbol	Pad diameter
32	ø32
40	ø40
50	ø50
63	ø63
80	ø80
100	ø100
125	ø125

**Pad form**

Symbol	Form
UM	Flat type with groove
BM	Belows type with groove

**Mounting thread size**

	Symbol	Mounting Thread size	ø32 to ø50	ø63 to ø125
		Male thread	AL14 AL16	M14 x 1 M16 x 1.5
Female thread	B8 B12	M8 x 1.25 M12 x 1.75	● —	— ●

**Pad material**

Symbol	Material
N	NBR
S	Silicone rubber
U	Urethane rubber
F	FKM
CL	Mark-free NBR

\* Refer to page 477 for replacement parts.

### Dimensions/With Ball Joint Male Thread Adapter: Vacuum Inlet Lateral

Pad diameter **ø32, ø40**

Pad form **Flat type with groove**

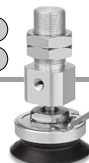

ZP3E-YF32UM□-AL14

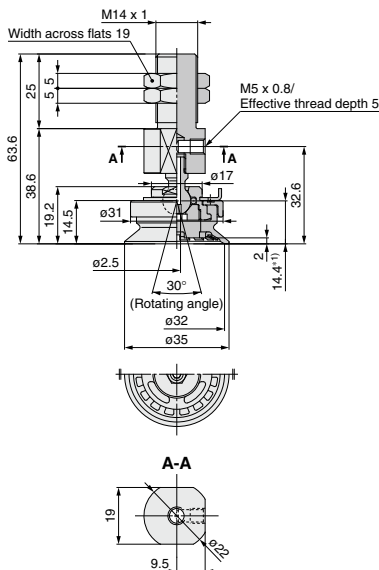

**Weights** [g]

Model	Pad material		
	N/U/CL	S	F
ZP3E-YF32UM□-AL14	71.7	71.3	74.1

ZP3E-YF40UM□-AL14

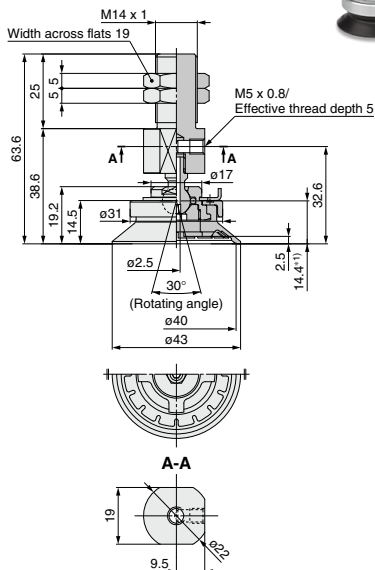

**Weights** [g]

Model	Pad material		
	N/U/CL	S	F
ZP3E-YF40UM□-AL14	72.7	72.3	75.8

ZP3

ZP3E

ZP2

ZP2V

ZP

ZPT

ZPR

XT661

\*1) Center of the rotating angle

# ZP3E Series

Dimensions/With Ball Joint Male Thread Adapter: Vacuum Inlet

Lateral

Pad diameter  $\phi 50$  to  $\phi 100$

Pad form Flat type with groove



ZP3E-YF50UM□-AL14

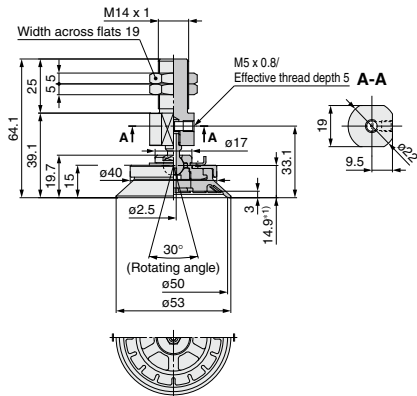

**Weights**

Model	Pad material		
	N/U/CL	S	F
ZP3E-YF50UM□-AL14	90.8	90.0	96.3

ZP3E-YF63UM□-AL16

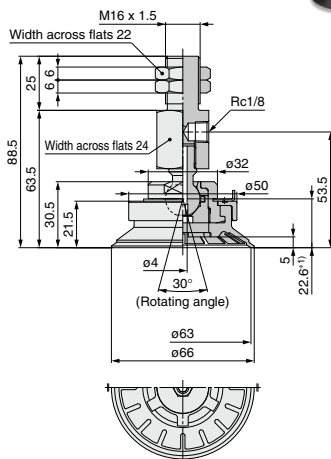

**Weights**

Model	Pad material		
	N/U/CL	S	F
ZP3E-YF63UM□-AL16	291	290	302

ZP3E-YF80UM□-AL16

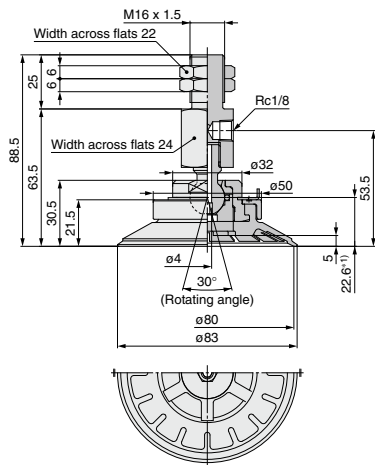

**Weights**

Model	Pad material		
	N/U/CL	S	F
ZP3E-YF80UM□-AL16	300	297	315

ZP3E-YF100UM□-AL16

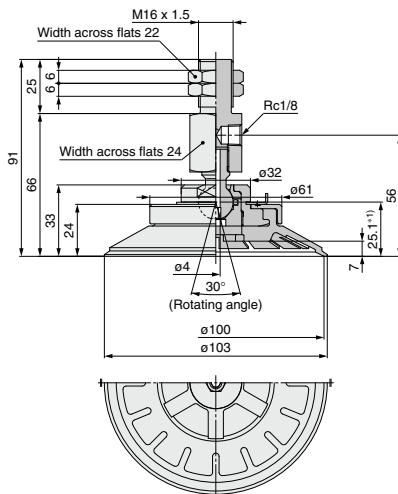

**Weights**

Model	Pad material		
	N/U/CL	S	F
ZP3E-YF100UM□-AL16	338	334	364

\*1) Center of the rotating angle

Dimensions/With Ball Joint Male Thread Adapter: Vacuum Inlet Lateral

**Pad diameter**     $\phi 125$   
**Pad form**        Flat type with groove



**ZP3E-YF125UM□-AL16**

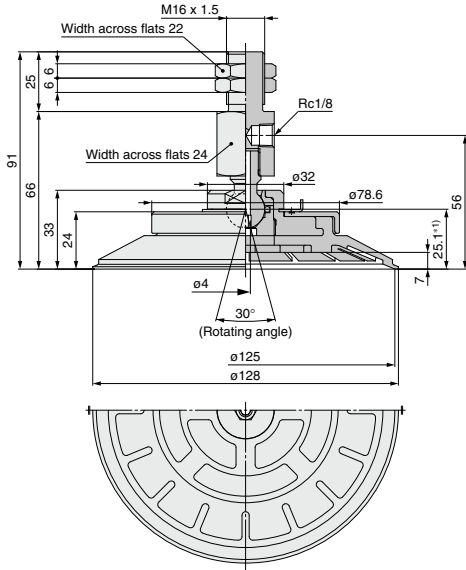

**Weights** [g]

Model	Pad material	N/U/CL	S	F
	ZP3E-YF125UM□-AL16		415	409

\*1) Center of the rotating angle

ZP3
ZP3E
ZP2
ZP2V
ZP
ZPT
ZPR
XT661

# ZP3E Series

Dimensions/With Ball Joint Female Thread Adapter: Vacuum Inlet

Lateral

Pad diameter  $\phi 32$  to  $\phi 63$

Pad form Flat type with groove



## ZP3E-YF32UM□-B8

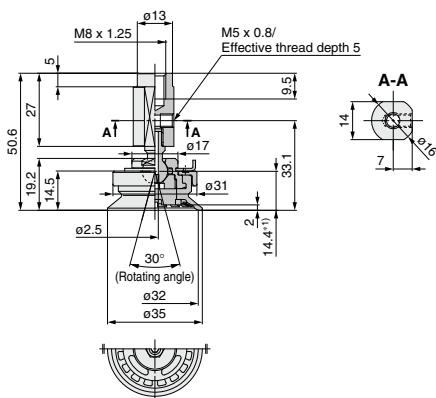

### Weights

[g]

Model	Pad material		
	N/U/CL	S	F
ZP3E-YF32UM□-B8	45.1	44.7	47.5

## ZP3E-YF40UM□-B8

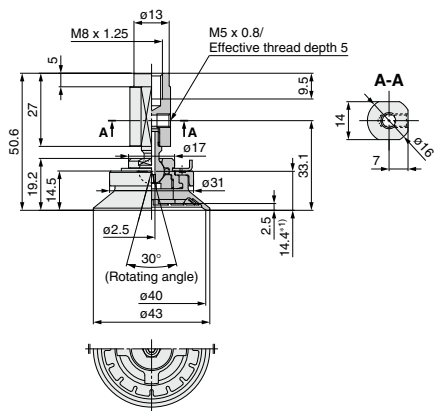

### Weights

[g]

Model	Pad material		
	N/U/CL	S	F
ZP3E-YF40UM□-B8	46.1	45.7	49.2

## ZP3E-YF50UM□-B8

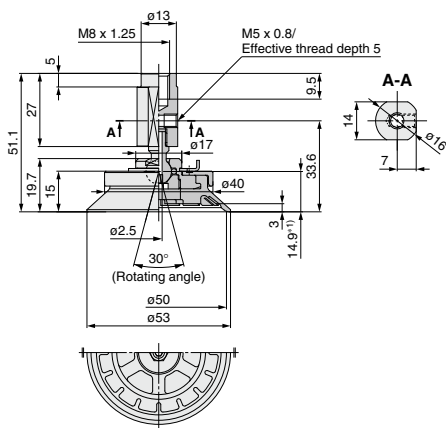

### Weights

[g]

Model	Pad material		
	N/U/CL	S	F
ZP3E-YF50UM□-B8	64.2	63.4	69.7

## ZP3E-YF63UM□-B12

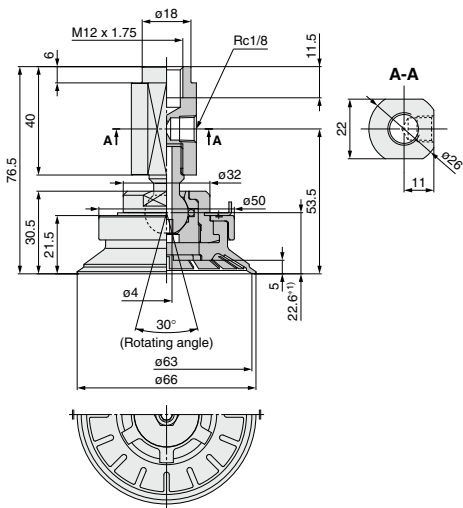

### Weights

[g]

Model	Pad material		
	N/U/CL	S	F
ZP3E-YF63UM□-B12	164	163	175

\*1) Center of the rotating angle



Dimensions/With Ball Joint Female Thread Adapter: Vacuum Inlet **Pad diameter**  $\phi 80$  to  $\phi 125$   
**Pad form** Flat type with groove

**ZP3E-YF80UM□-B12**

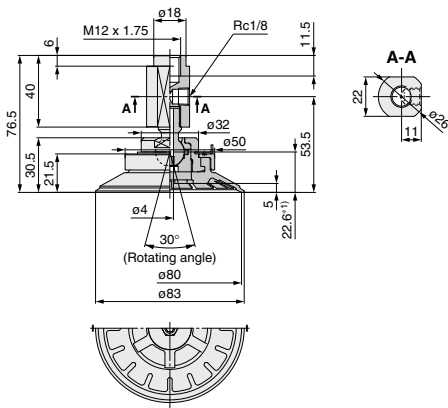

**ZP3E-YF100UM□-B12**

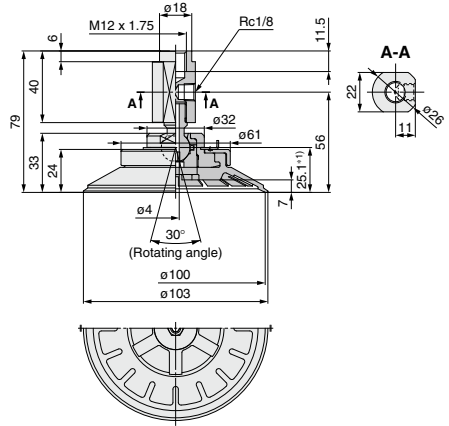

**Weights** [g]

Model	Pad material	N/U/CL	S	F
ZP3E-YF80UM□-B12		172	170	188

**Weights** [g]

Model	Pad material	N/U/CL	S	F
ZP3E-YF100UM□-B12		210	207	236

**ZP3E-YF125UM□-B12**

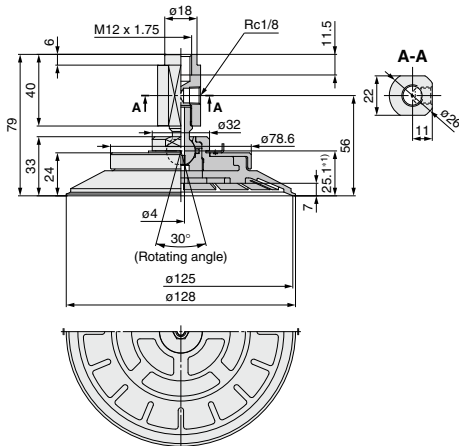

**Weights** [g]

Model	Pad material	N/U/CL	S	F
ZP3E-YF125UM□-B12		288	281	335

\*1) Center of the rotating angle

- ZP3
- ZP3E
- ZP2
- ZP2V
- ZP
- ZPT
- ZPR
- XT661

# ZP3E Series

Dimensions/With Ball Joint Male Thread Adapter: Vacuum Inlet

Lateral

Pad diameter  $\phi 32$  to  $\phi 63$

Pad form Bellows type with groove



ZP3E-YF32BM□-AL14

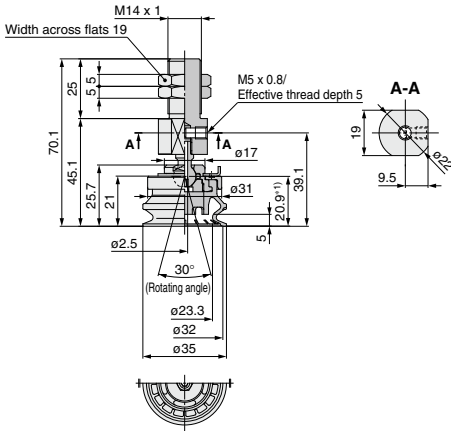

**Weights**

[g]

Model	Pad material	N/U/CL	S	F
ZP3E-YF32BM□-AL14		60.9	60.4	64.6

ZP3E-YF40BM□-AL14

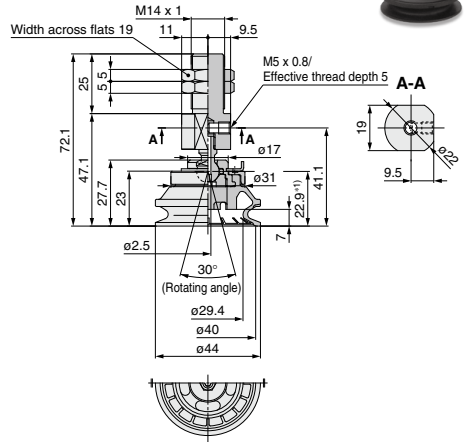

**Weights**

[g]

Model	Pad material	N/U/CL	S	F
ZP3E-YF40BM□-AL14		64.9	64.1	70.9

ZP3E-YF50BM□-AL14

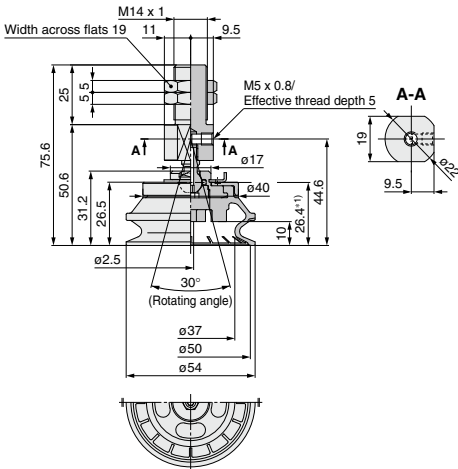

**Weights**

[g]

Model	Pad material	N/U/CL	S	F
ZP3E-YF50BM□-AL14		86.6	85.1	97.1

ZP3E-YF63BM□-AL16

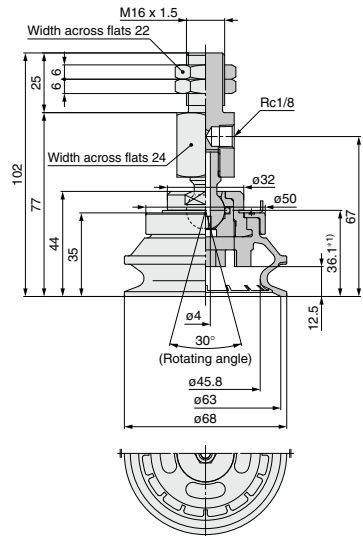

**Weights**

[g]

Model	Pad material	N/U/CL	S	F
ZP3E-YF63BM□-AL16		201	198	221

\*1) Center of the rotating angle

Dimensions/With Ball Joint Male Thread Adapter: Vacuum Inlet Lateral

Pad diameter  $\phi 80$  to  $\phi 125$

Pad form Bellows type with groove



**ZP3E-YF80BM□-AL16**

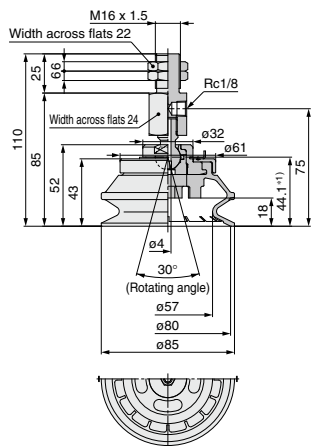

**Weights** [g]

Model	Pad material	N/U/CL	S	F
ZP3E-YF80BM□-AL16		246	241	281

**ZP3E-YF100BM□-AL16**

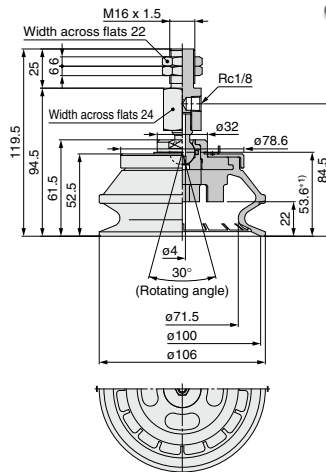

**Weights** [g]

Model	Pad material	N/U/CL	S	F
ZP3E-YF100BM□-AL16		354	343	426

**ZP3E-YF125BM□-AL16**

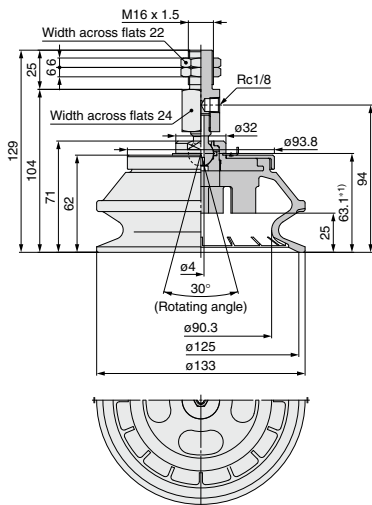

**Weights** [g]

Model	Pad material	N/U/CL	S	F
ZP3E-YF125BM□-AL16		511	492	648

\*1) Center of the rotating angle

ZP3

ZP3E

ZP2

ZP2V

ZP

ZPT

ZPR

XT661

# ZP3E Series

Dimensions/With Ball Joint Female Thread Adapter: Vacuum Inlet

Lateral

Pad diameter  $\phi 32$  to  $\phi 63$

Pad form Bellows type with groove



ZP3E-YF32BM□-B8

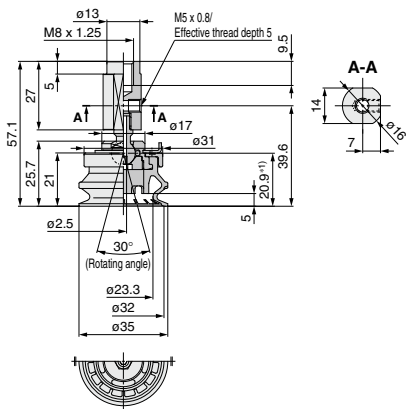

Weights [g]

Model	Pad material	N/U/CL	S	F
ZP3E-YF32BM□-B8		42.9	42.4	46.5

ZP3E-YF40BM□-B8

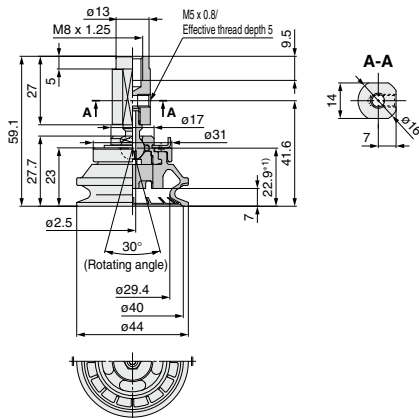

Weights [g]

Model	Pad material	N/U/CL	S	F
ZP3E-YF40BM□-B8		46.9	46.0	52.9

ZP3E-YF50BM□-B8

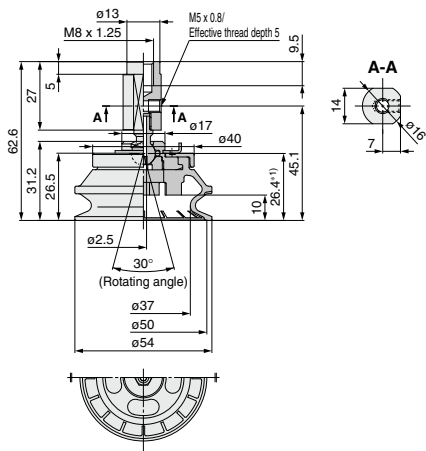

Weights [g]

Model	Pad material	N/U/CL	S	F
ZP3E-YF50BM□-B8		68.5	67.0	79.0

ZP3E-YF63BM□-B12

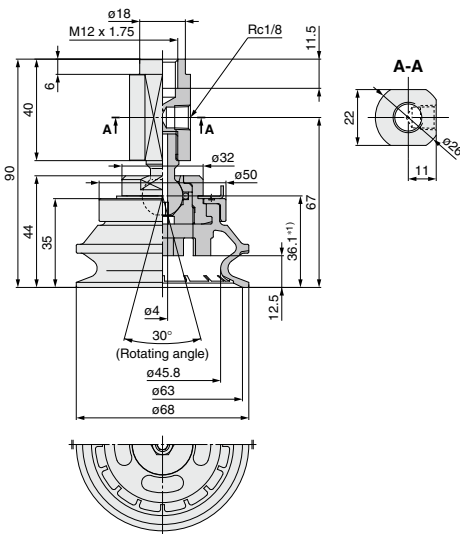

Weights [g]

Model	Pad material	N/U/CL	S	F
ZP3E-YF63BM□-B12		168	165	188

\*1) Center of the rotating angle



Dimensions/With Ball Joint Female Thread Adapter: Vacuum Inlet

Lateral

Pad diameter  $\phi 80$  to  $\phi 125$

Pad form Bellows type with groove



**ZP3E-YF80BM□-B12**

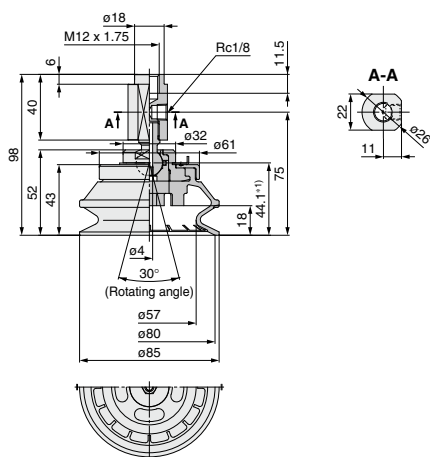

**ZP3E-YF100BM□-B12**

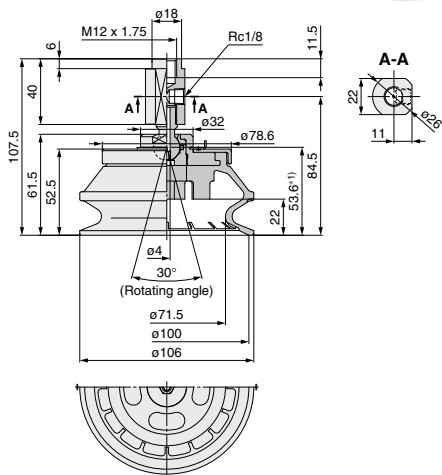

**Weights**

[g]

Model	Pad material		
	N/U/CL	S	F
ZP3E-YF80BM□-B12	213	208	248

**Weights**

[g]

Model	Pad material		
	N/U/CL	S	F
ZP3E-YF100BM□-B12	354	343	426

**ZP3E-YF125BM□-B12**

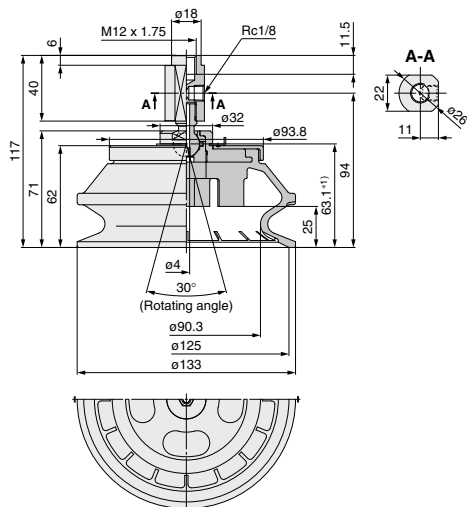

**Weights**

[g]

Model	Pad material		
	N/U/CL	S	F
ZP3E-YF125BM□-B12	511	492	648

ZP3

ZP3E

ZP2

ZP2V

ZP

ZPT

ZPR

XT661

\*1) Center of the rotating angle

# ZP3E Series

## How to Order

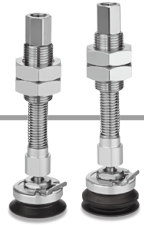

With ball joint buffer

### ZP3E - T F 32 UM N JB 10

Vacuum inlet direction

Symbol	Direction
T	Vertical

Specification (mechanism)

Symbol	Specification
F	Ball joint

Pad diameter

Symbol	Pad diameter
32	ø32
40	ø40
50	ø50
63	ø63
80	ø80
100	ø100
125	ø125

Buffer specification

JB	Rotating, With bushing
----	------------------------

Stroke (■)

Symbol	Stroke
10	10 mm
30	30 mm
50	50 mm

Pad form

Symbol	Form
UM	Flat type with groove
BM	Bel lows type with groove

Pad material

Symbol	Material
N	NBR
S	Silicone rubber
U	Urethane rubber
F	FKM
CL	Mark-free NBR

\* Refer to page 478 for replacement parts.

## Specifications

Buffer specification	Pad diameter	Mounting	Tightening torque [N·m]	Stroke [mm]	Spring reactive force [N]	
					At 0 stroke	At full stroke
Rotating	ø32 to ø50	M18 x 1.5	28 to 32	10	5	6.5
				30	5	8.5
				50	5	10.5
	ø63 to ø125	M22 x 1.5	45 to 50	10	10	11.5
				30	10	13.5
				50	10	15.5

## Dimensions/With Ball Joint Buffer: Vacuum Inlet

Vertical

Pad diameter ø32, ø40

Pad form Flat type with groove



ZP3E-TF32UM□JB■

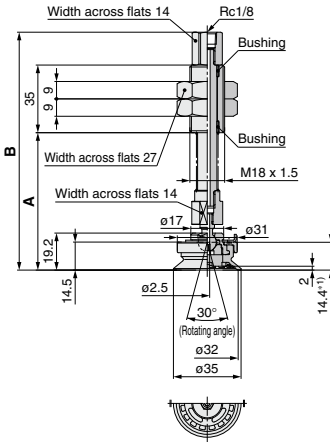

ZP3E-TF40UM□JB■

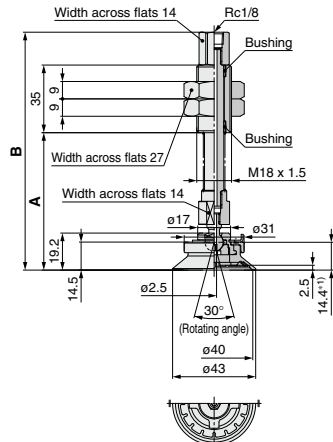

## Dimensions

Model	A	B	Weight (g)/Pad material		
			N/U/CL	S	F
ZP3E-TF32UM□JB10	71.1	123.1	204	204	207
ZP3E-TF32UM□JB30	96.1	148.1	219	218	221
ZP3E-TF32UM□JB50	116.1	168.1	230	230	233

## Dimensions

Model	A	B	Weight (g)/Pad material		
			N/U/CL	S	F
ZP3E-TF40UM□JB10	71.1	123.1	205	205	208
ZP3E-TF40UM□JB30	96.1	148.1	220	219	223
ZP3E-TF40UM□JB50	116.1	168.1	231	231	234

\*1) Center of the rotating angle

Dimensions/With Ball Joint Buffer: Vacuum Inlet **Vertical**

Pad diameter  $\phi 50$  to  $\phi 100$

Pad form Flat type with groove



**ZP3E-TF50UM□JB■**

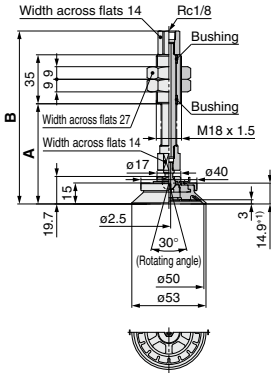

**ZP3E-TF63UM□JB■**

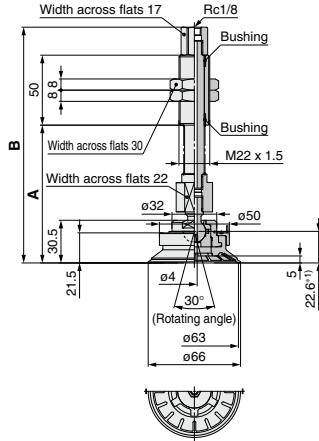

**Dimensions**

Model	A	B	Weight [g]/Pad material		
			N/U/CL	S	F
ZP3E-TF50UM□JB10	71.6	123.6	223	222	229
ZP3E-TF50UM□JB30	96.6	148.6	238	237	243
ZP3E-TF50UM□JB50	116.6	168.6	249	249	255

**Dimensions**

Model	A	B	Weight [g]/Pad material		
			N/U/CL	S	F
ZP3E-TF63UM□JB10	98.5	168.5	434	433	445
ZP3E-TF63UM□JB30	123.5	193.5	464	462	474
ZP3E-TF63UM□JB50	143.5	213.5	487	485	497

**ZP3E-TF80UM□JB■**

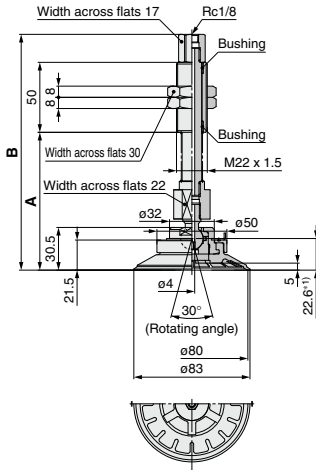

**ZP3E-TF100UM□JB■**

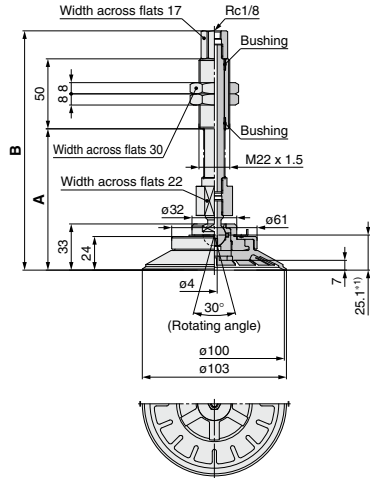

**Dimensions**

Model	A	B	Weight [g]/Pad material		
			N/U/CL	S	F
ZP3E-TF80UM□JB10	98.5	168.5	443	441	458
ZP3E-TF80UM□JB30	123.5	193.5	472	470	487
ZP3E-TF80UM□JB50	143.5	213.5	495	493	510

**Dimensions**

Model	A	B	Weight [g]/Pad material		
			N/U/CL	S	F
ZP3E-TF100UM□JB10	101	171	481	477	507
ZP3E-TF100UM□JB30	126	196	510	506	536
ZP3E-TF100UM□JB50	146	216	533	529	559

ZP3

ZP3E

ZP2

ZP2V

ZP

ZPT

ZPR

XT661

\*1) Center of the rotating angle

# ZP3E Series

Dimensions/With Ball Joint Buffer: Vacuum Inlet

Vertical

Pad diameter  $\phi 125$

Pad form Flat type with groove

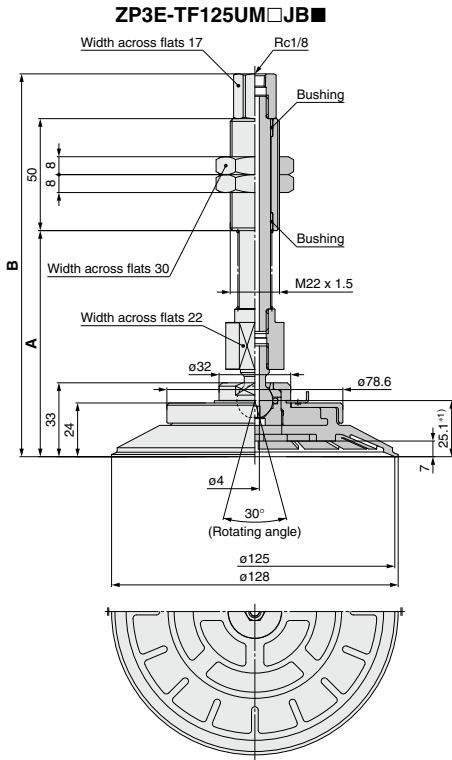

## Dimensions

Model	A	B	Weight [g]/Pad material		
			N/U/CL	S	F
ZP3E-TF125UM□JB10	101	171	558	552	605
ZP3E-TF125UM□JB30	126	196	588	581	634
ZP3E-TF125UM□JB50	146	216	610	604	657

\*1) Center of the rotating angle

**Dimensions/With Ball Joint Buffer: Vacuum Inlet**



Pad diameter  $\phi 32$  to  $\phi 63$

Pad form *Belows type with groove*



**ZP3E-TF32BM□JB■**

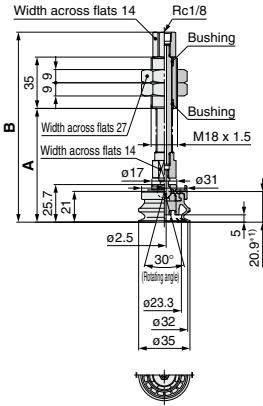

**ZP3E-TF40BM□JB■**

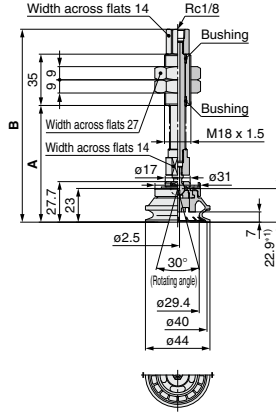

**Dimensions**

Model	A	B	Weight [g]/Pad material		
			N/U/CL	S	F
ZP3E-TF32BM□JB10	77.6	129.6	206	206	210
ZP3E-TF32BM□JB30	102.6	154.6	221	220	224
ZP3E-TF32BM□JB50	122.6	174.6	232	232	236

**Dimensions**

Model	A	B	Weight [g]/Pad material		
			N/U/CL	S	F
ZP3E-TF40BM□JB10	79.6	131.6	210	209	216
ZP3E-TF40BM□JB30	104.6	156.6	225	224	231
ZP3E-TF40BM□JB50	124.6	176.6	236	235	242

**ZP3E-TF50BM□JB■**

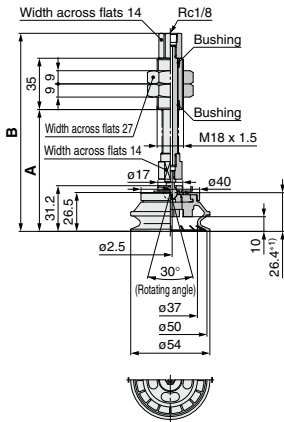

**ZP3E-TF63BM□JB■**

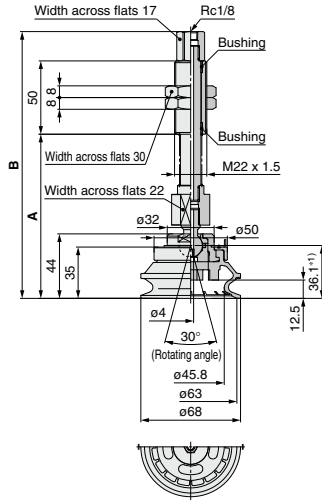

**Dimensions**

Model	A	B	Weight [g]/Pad material		
			N/U/CL	S	F
ZP3E-TF50BM□JB10	83.1	135.1	232	230	242
ZP3E-TF50BM□JB30	108.1	160.1	246	245	257
ZP3E-TF50BM□JB50	128.1	180.1	258	256	268

**Dimensions**

Model	A	B	Weight [g]/Pad material		
			N/U/CL	S	F
ZP3E-TF63BM□JB10	112	182	451	448	471
ZP3E-TF63BM□JB30	137	207	480	477	501
ZP3E-TF63BM□JB50	157	227	503	500	523

- ZP3
- ZP3E
- ZP2
- ZP2V
- ZP
- ZPT
- ZPR
- XT661

\*1) Center of the rotating angle

# ZP3E Series

Dimensions/With Ball Joint Buffer: Vacuum Inlet

Vertical

Pad diameter  $\phi 80$  to  $\phi 125$

Pad form Bellows type with groove



## ZP3E-TF80BM□JB■

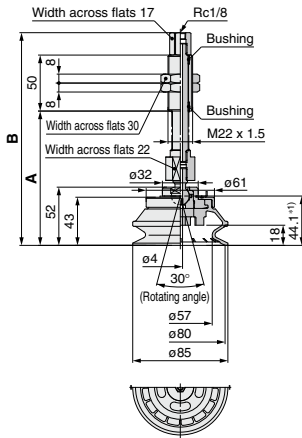

## ZP3E-TF100BM□JB■

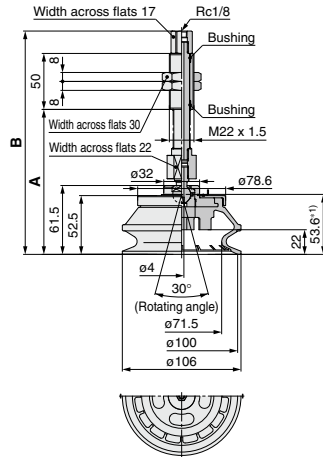

### Dimensions

Model	A	B	Weight (g)/Pad material		
			N/U/CL	S	F
ZP3E-TF80BM□JB10	120	190	496	491	531
ZP3E-TF80BM□JB30	145	215	525	520	561
ZP3E-TF80BM□JB50	165	235	548	543	583

### Dimensions

Model	A	B	Weight (g)/Pad material		
			N/U/CL	S	F
ZP3E-TF100BM□JB10	129.5	199.5	604	593	676
ZP3E-TF100BM□JB30	154.5	224.5	633	622	705
ZP3E-TF100BM□JB50	174.5	244.5	656	645	728

## ZP3E-TF125BM□JB■

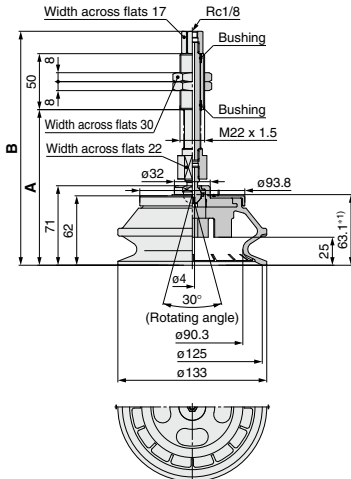

### Dimensions

Model	A	B	Weight (g)/Pad material		
			N/U/CL	S	F
ZP3E-TF125BM□JB10	139	209	761	742	898
ZP3E-TF125BM□JB30	164	234	790	771	927
ZP3E-TF125BM□JB50	184	254	813	794	950

\*1) Center of the rotating angle

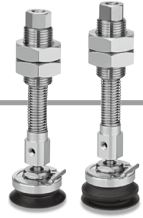

### How to Order

With ball joint buffer

**ZP3E - Y F 32 UM N JB 10**

**Vacuum inlet direction**

Symbol	Direction
Y	Lateral

**Specification (mechanism)**

Symbol	Specification
F	Ball joint

**Pad diameter**

Symbol	Pad diameter
32	ø32
40	ø40
50	ø50
63	ø63
80	ø80
100	ø100
125	ø125

**Buffer specification**

Symbol	Specification
JB	Rotating, With bushing

**Stroke (■)**

Symbol	Stroke
10	10 mm
30	30 mm
50	50 mm

**Pad form**

Symbol	Form
UM	Flat type with groove
BM	Bellows type with groove

**Pad material**

Symbol	Material
N	NBR
S	Silicone rubber
U	Urethane rubber
F	FKM
CL	Mark-free NBR

\* Refer to page 478 for replacement parts.

### Specifications

Buffer specification	Pad diameter	Mounting	Tightening torque [N·m]	Stroke [mm]	Spring reactive force [N]	
					At 0 stroke	At full stroke
Rotating	ø32 to ø50	M18 x 1.5	28 to 32	10	5	6.5
				30	5	8.5
				50	5	10.5
	ø63 to ø125	M22 x 1.5	45 to 50	10	10	11.5
				30	10	13.5
				50	10	15.5

### Dimensions/With Ball Joint Buffer: Vacuum Inlet Lateral

Pad diameter **ø32, ø40**

Pad form **Flat type with groove**



ZP3E-YF32UM□JB■

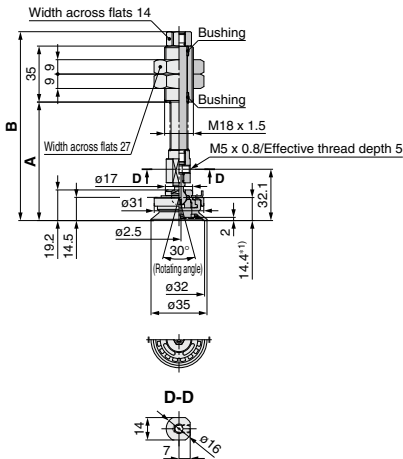

ZP3E-YF40UM□JB■

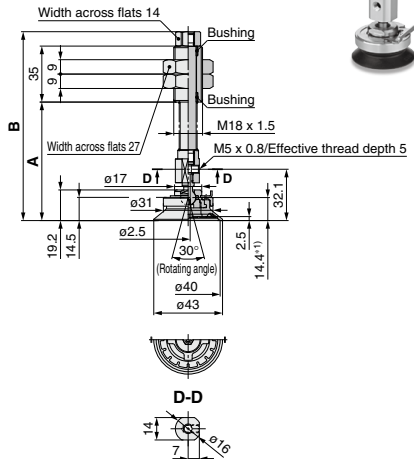

#### Dimensions

Model	A	B	Weight [g]/Pad material		
			N/U/CL	S	F
ZP3E-YF32UM□JB10	74.1	118.1	202	202	204
ZP3E-YF32UM□JB30	99.1	143.1	218	218	221
ZP3E-YF32UM□JB50	119.1	163.1	231	230	233

#### Dimensions

Model	A	B	Weight [g]/Pad material		
			N/U/CL	S	F
ZP3E-YF40UM□JB10	74.1	118.1	203	203	206
ZP3E-YF40UM□JB30	99.1	143.1	219	219	222
ZP3E-YF40UM□JB50	119.1	163.1	232	231	235

\*1) Center of the rotating angle





**Dimensions/With Ball Joint Buffer: Vacuum Inlet**

Lateral

Pad diameter  $\phi 125$

Pad form Flat type with groove



**ZP3E-YF125UM□JB■**

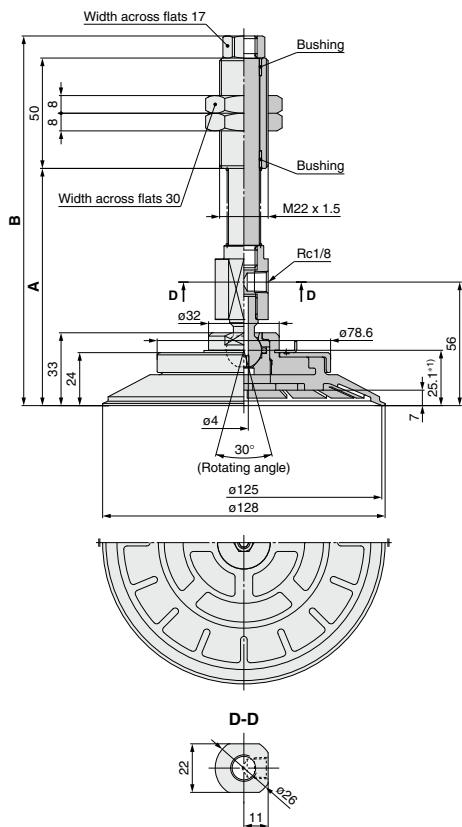

**Dimensions**

Model	A	B	Weight (g)/Pad material		
			N/U/CL	S	F
ZP3E-YF125UM□JB10	107.5	167.5	559	553	606
ZP3E-YF125UM□JB30	132.5	192.5	591	584	637
ZP3E-YF125UM□JB50	152.5	212.5	616	609	662

\*1) Center of the rotating angle

ZP3

ZP3E

ZP2

ZP2V

ZP

ZPT  
ZPR

XT661

# ZP3E Series

Dimensions/With Ball Joint Buffer: Vacuum Inlet

Lateral

Pad diameter  $\phi 32$  to  $\phi 63$

Pad form Bellows type with groove



## ZP3E-YF32BM□JB■

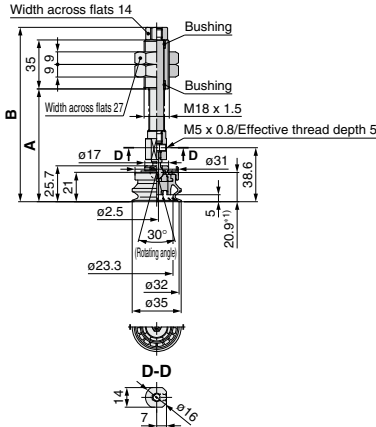

### Dimensions

Model	A	B	Weight (g)/Pad material		
			N/U/CL	S	F
ZP3E-YF32BM□JB10	80.6	124.6	204	203	208
ZP3E-YF32BM□JB30	105.6	149.6	220	220	224
ZP3E-YF32BM□JB50	125.6	169.6	233	232	236

## ZP3E-YF40BM□JB■

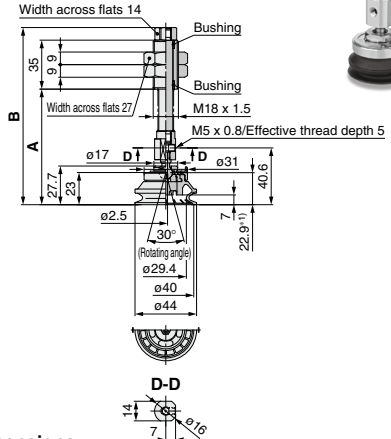

### Dimensions

Model	A	B	Weight (g)/Pad material		
			N/U/CL	S	F
ZP3E-YF40BM□JB10	82.6	126.6	208	207	214
ZP3E-YF40BM□JB30	107.6	151.6	224	223	230
ZP3E-YF40BM□JB50	127.6	171.6	237	236	243

## ZP3E-YF50BM□JB■

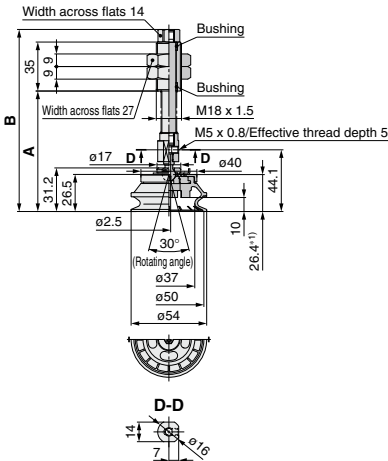

### Dimensions

Model	A	B	Weight (g)/Pad material		
			N/U/CL	S	F
ZP3E-YF50BM□JB10	86.1	130.1	230	228	240
ZP3E-YF50BM□JB30	111.1	155.1	246	244	256
ZP3E-YF50BM□JB50	131.1	175.1	258	257	269

## ZP3E-YF63BM□JB■

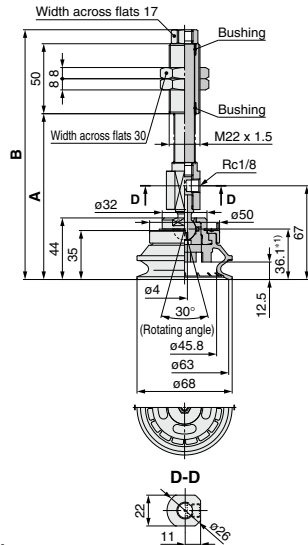

### Dimensions

Model	A	B	Weight (g)/Pad material		
			N/U/CL	S	F
ZP3E-YF63BM□JB10	118.5	178.5	452	449	472
ZP3E-YF63BM□JB30	143.5	203.5	483	480	504
ZP3E-YF63BM□JB50	163.5	223.5	508	505	529

\*1) Center of the rotating angle

**Dimensions/With Ball Joint Buffer: Vacuum Inlet**

Pad diameter  $\phi 80$  to  $\phi 125$

Pad form **Bel lows type with groove**



**ZP3E-YF80BM□JB■**

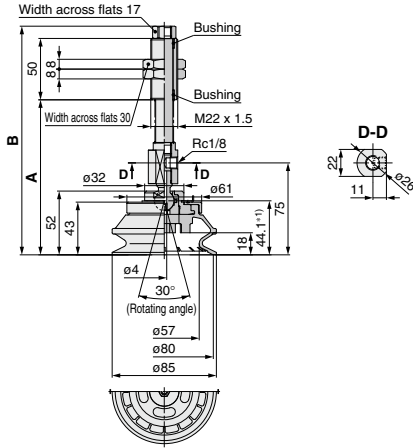

**ZP3E-YF100BM□JB■**

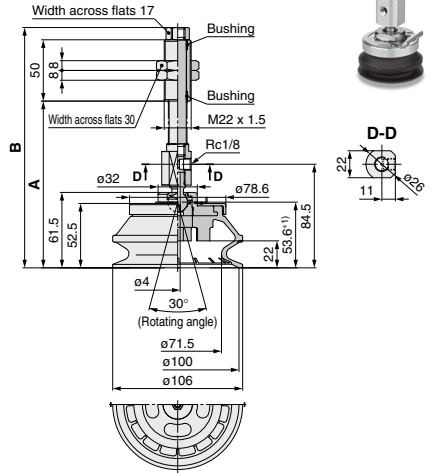

**Dimensions**

Model	A	B	Weight (g)/Pad material		
			N/U/CL	S	F
ZP3E-YF80BM□JB10	126.5	186.5	497	492	532
ZP3E-YF80BM□JB30	151.5	211.5	529	524	564
ZP3E-YF80BM□JB50	171.5	231.5	553	548	589

**Dimensions**

Model	A	B	Weight (g)/Pad material		
			N/U/CL	S	F
ZP3E-YF100BM□JB10	136	196	605	594	677
ZP3E-YF100BM□JB30	161	221	636	625	708
ZP3E-YF100BM□JB50	181	241	661	650	733

**ZP3E-YF125UM□JB■**

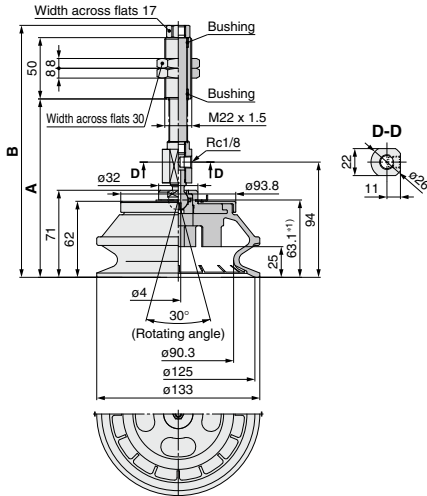

**Dimensions**

Model	A	B	Weight (g)/Pad material		
			N/U/CL	S	F
ZP3E-YF125BM□JB10	145.5	205.5	762	743	899
ZP3E-YF125BM□JB30	170.5	230.5	793	774	930
ZP3E-YF125BM□JB50	190.5	250.5	818	799	955

\*1) Center of the rotating angle

ZP3

ZP3E

ZP2

ZP2V

ZP

ZPT

ZPR

XT661

# ZP3E Series Construction

## Pad with Adapter

### Male thread

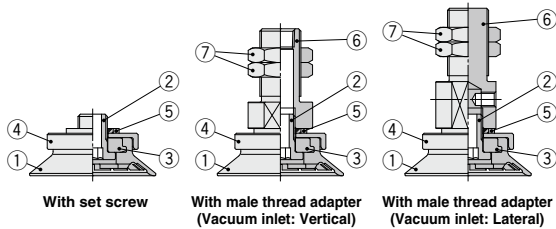

### Female thread

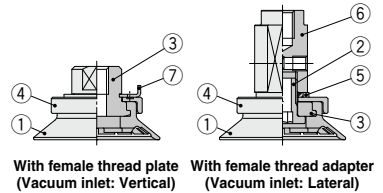

### Component Parts (Male thread)

No.	Description	Material (Surface treatment)	Note
1	Vacuum pad	NBR, Silicone rubber, Urethane rubber, FKM, Mark-free NBR	Pad form: Flat type with groove, Bellows type with groove
2	Set screw	Brass (Electroless nickel plating)	
3	Plate	Aluminum alloy (Clear anodized)	
4	Holder	Aluminum alloy (Clear anodized)	Pad diameter: $\phi 32$ to $\phi 50$
5	Seal washer	Steel strip/NBR	Pad diameter: $\phi 63$ to $\phi 125$
6	Adapter	Aluminum alloy (Clear anodized)	Pad diameter: $\phi 32$ to $\phi 50$
		Brass (Electroless nickel plating)	Pad diameter: $\phi 63$ to $\phi 125$
7	Nut	Structural steel (Electroless nickel plating)	Pad diameter: $\phi 32$ to $\phi 50$
		Structural steel (Nickel plating)	Pad diameter: $\phi 63$ to $\phi 125$

\* ② to ⑦ are used for both the flat type with groove and the bellows type with groove.

### Component Parts (Female thread)

No.	Description	Material (Surface treatment)	Note
1	Vacuum pad	NBR, Silicone rubber, Urethane rubber, FKM, Mark-free NBR	Pad form: Flat type with groove, Bellows type with groove
2	Set screw	Brass (Electroless nickel plating)	
3	Plate	Aluminum alloy (Clear anodized)	
4	Holder	Aluminum alloy (Clear anodized)	• With female thread plate: Pad diameter: $\phi 32$ to $\phi 125$ • With female thread adapter: Pad diameter: $\phi 32$ to $\phi 50$
		Structural steel (Electroless nickel plating)	• With female thread adapter: Pad diameter: $\phi 63$ to $\phi 125$
5	Seal washer	Steel strip/NBR	
6	Adapter	Aluminum alloy (Clear anodized)	
7	Stopper	Stainless steel	

## Pad with Buffer

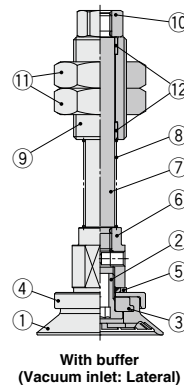
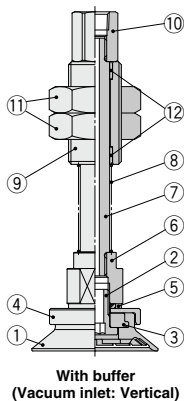

### Component Parts

No.	Description	Material (Surface treatment)	Note
1	Vacuum pad	NBR, Silicone rubber, Urethane rubber, FKM, Mark-free NBR	Pad form: Flat type with groove, Bellows type with groove
2	Set screw	Brass (Electroless nickel plating)	
3	Plate	Aluminum alloy (Clear anodized)	
4	Holder	Aluminum alloy (Clear anodized)	Pad diameter: $\phi 32$ to $\phi 50$
5	Seal washer	Soft iron/NBR (Zinc chromated)	Pad diameter: $\phi 63$ to $\phi 125$
6	Adapter	Aluminum alloy (Clear anodized)	
7	Piston rod	Structural steel (Hard chrome plating)	
8	Return spring	Stainless steel	
9	Buffer body	Brass (Electroless nickel plating)	
10	Buffer adapter	Brass (Electroless nickel plating)	
11	Nut	Structural steel (Nickel plating)	
12	Bushing	—	

\* ② to ⑫ are used for both the flat type with groove and the bellows type with groove.

**Pad with Ball Joint Adapter**

ø32 to ø50  
Male thread

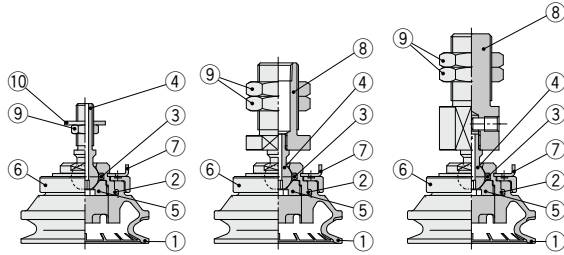

Male thread (for direct mounting)      With male thread adapter (Vacuum inlet: Vertical)      With male thread adapter (Vacuum inlet: Lateral)

Female thread

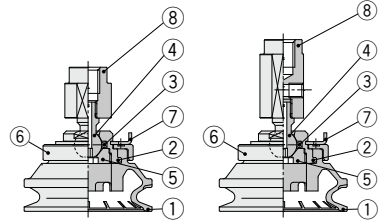

With female thread adapter (Vacuum inlet: Vertical)      With female thread adapter (Vacuum inlet: Lateral)

**Component Parts**

No.	Description	Material (Surface treatment)	Note
1	Vacuum pad	NBR, Silicone rubber, Urethane rubber, FKM, Mark-free NBR	Pad form: Flat type with groove, Bellows type with groove
2	Plate	Stainless steel	
3	O-ring	FKM	
4	Shaft	Stainless steel	
5	Shaft ring	Stainless steel	
6	Holder	Aluminum alloy (Clear anodized)	
7	Stopper	Stainless steel	
8	Adapter	Aluminum alloy (Clear anodized)	
9	Nut	Brass (Electroless nickel plating)	
10	Seal washer	Soft iron/NBR (Zinc chromated)	

\* ② to ⑩ are used for both the flat type with groove and the bellows type with groove.

ø63 to ø125  
Male thread

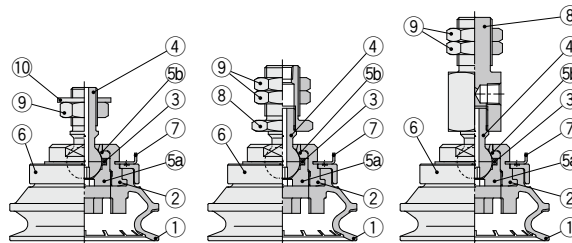

Male thread (for direct mounting)      With male thread adapter (Vacuum inlet: Vertical)      With male thread adapter (Vacuum inlet: Lateral)

Female thread

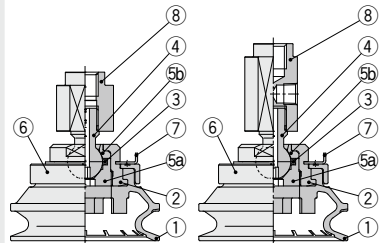

With female thread adapter (Vacuum inlet: Vertical)      With female thread adapter (Vacuum inlet: Lateral)

**Component Parts (Male thread)**

No.	Description	Material (Surface treatment)	Note
1	Vacuum pad	NBR, Silicone rubber, Urethane rubber, FKM, Mark-free NBR	Pad form: Flat type with groove, Bellows type with groove
2	Plate	Aluminum alloy (Clear anodized)	
3	O-ring	FKM	
4	Shaft	Stainless steel	
5a	Shaft ring A	Stainless steel	
5b	Shaft ring B	Stainless steel	
6	Holder	Aluminum alloy (Clear anodized)	
7	Stopper	Stainless steel	
8	Adapter	Brass (Electroless nickel plating)	
9	Nut	Structural steel (Nickel plating) Structural steel (Zinc chromated)	Male thread adapter Male thread for direct mounting adapter
10	Seal washer	Soft iron/NBR (Zinc chromated)	

\* ② to ⑩ are used for both the flat type with groove and the bellows type with groove.

**Component Parts (Female thread)**

No.	Description	Material (Surface treatment)	Note
1	Vacuum pad	NBR, Silicone rubber, Urethane rubber, FKM, Mark-free NBR	Pad form: Flat type with groove, Bellows type with groove
2	Plate	Aluminum alloy (Clear anodized)	
3	O-ring	FKM	
4	Shaft	Stainless steel	
5a	Shaft ring A	Stainless steel	
5b	Shaft ring B	Stainless steel	
6	Holder	Aluminum alloy (Clear anodized)	
7	Stopper	Stainless steel	
8	Adapter	Aluminum alloy (Clear anodized)	

ZP3

ZP3E

ZP2

ZP2V

ZP

ZPT

ZPR

XT661

# ZP3E Series

## Pad with Ball Joint Buffer

ø32 to ø50

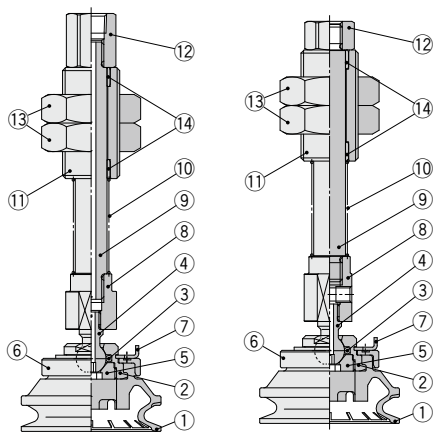

With ball joint buffer  
(Vacuum inlet: Vertical)

With ball joint buffer  
(Vacuum inlet: Lateral)

### Component Parts

No.	Description	Material (Surface treatment)	Note
1	Vacuum pad	NBR, Silicone rubber, Urethane rubber, FKM, Mark-free NBR	Pad form: Flat type with groove, Bellows type with groove
2	Plate	Stainless steel	
3	O-ring	FKM	
4	Shaft	Stainless steel	
5	Shaft ring	Stainless steel	
6	Holder	Aluminum alloy (Clear anodized)	
7	Stopper	Stainless steel	
8	Adapter	Aluminum alloy (Clear anodized)	
9	Piston rod	Structural steel (Hard chrome plating)	
10	Return spring	Stainless steel	
11	Buffer body	Brass (Electroless nickel plating)	
12	Buffer adapter	Brass (Electroless nickel plating)	
13	Nut	Structural steel (Nickel plating)	
14	Bushing	—	

\* ② to ⑭ are used for both the flat type with groove and the bellows type with groove.

ø63 to ø125

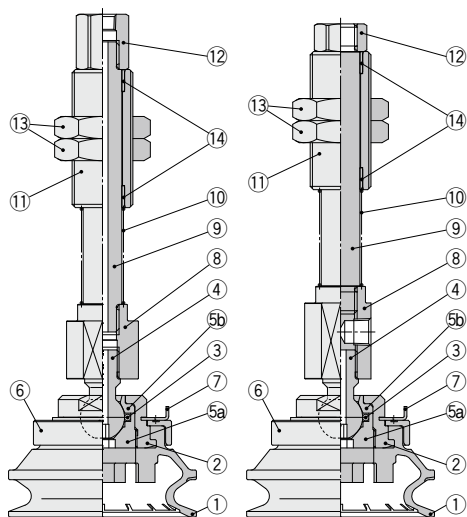

With ball joint buffer  
(Vacuum inlet: Vertical)

With ball joint buffer  
(Vacuum inlet: Lateral)

### Component Parts

No.	Description	Material (Surface treatment)	Note
1	Vacuum pad	NBR, Silicone rubber, Urethane rubber, FKM, Mark-free NBR	Pad form: Flat type with groove, Bellows type with groove
2	Plate	Aluminum alloy (Clear anodized)	
3	O-ring	FKM	
4	Shaft	Stainless steel	
5a	Shaft ring A	Stainless steel	
5b	Shaft ring B	Stainless steel	
6	Holder	Aluminum alloy (Clear anodized)	
7	Stopper	Stainless steel	
8	Adapter	Aluminum alloy (Clear anodized)	
9	Piston rod	Structural steel (Hard chromated)	
10	Return spring	Stainless steel	
11	Buffer body	Brass (Electroless nickel plating)	
12	Buffer adapter	Brass (Electroless nickel plating)	
13	Nut	Structural steel (Nickel plating)	
14	Bushing	—	

\* ② to ⑭ are used for both the flat type with groove and the bellows type with groove.

# Component Part No.

With Set Screw/With Male Thread Adapter: Vacuum Inlet 

ZP3E-T(32 to 50)(UM/BM)□-AL14  
ZP3E-T(63 to 125)(UM/BM)□-AL16

ZP3E-T(32 to 50)(UM/BM)□-A10  
ZP3E-T(63 to 125)(UM/BM)□-A16

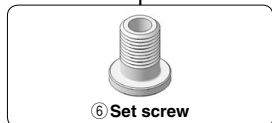
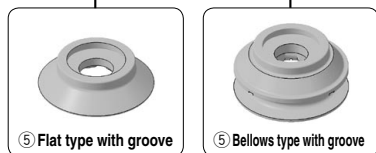
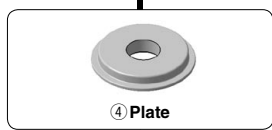
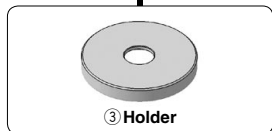
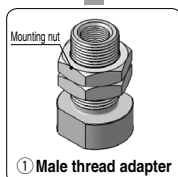
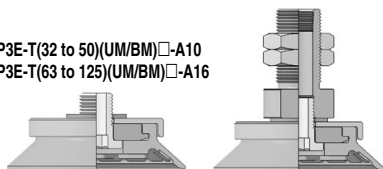

### ① Male thread adapter (With 2 mounting nuts)

Form/Diameter	Flat type with groove (UM)					Bellows type with groove (BM)								
Part no.	32	40	50	63	80	100	125	32	40	50	63	80	100	125
ZP3EA-TAL14	●	●	●	●	●	●	●	●	●	●	●	●	●	●
ZP3EA-TAL16	—	—	—	—	—	—	—	—	—	—	—	—	—	—

### ② Seal washer (Sales unit: 5 pcs.)

Part no.	Mounting thread size	Applicable set screw (⑥)
ZP3EA-SW10	M10 x 1	ZP3EA-A10
ZP3EA-SW16	M16 x 1.5	ZP3EA-A16

### ③ Holder

Form/Diameter	Flat type with groove (UM)					Bellows type with groove (BM)								
Part no.	32	40	50	63	80	100	125	32	40	50	63	80	100	125
ZP3EA-H1A	●	—	—	—	—	—	—	●	—	—	—	—	—	—
ZP3EA-H2A	—	●	—	—	—	—	—	—	●	—	—	—	—	—
ZP3EA-H3A	—	—	●	—	—	—	—	—	—	●	—	—	—	—
ZP3EA-H4A	—	—	—	●	—	—	—	—	—	—	●	—	—	—
ZP3EA-H5A	—	—	—	—	●	—	—	—	—	—	—	●	—	—
ZP3EA-H6A	—	—	—	—	—	●	—	—	—	—	—	—	●	—

### ④ Plate

Form/Diameter	Flat type with groove (UM)					Bellows type with groove (BM)								
Part no.	32	40	50	63	80	100	125	32	40	50	63	80	100	125
ZP3EA-P1	●	●	—	—	—	—	—	●	●	—	—	—	—	—
ZP3EA-P2	—	—	●	—	—	—	—	—	—	●	—	—	—	—
ZP3EA-P3	—	—	—	●	—	—	—	—	—	—	●	—	—	—
ZP3EA-P4	—	—	—	—	●	—	—	—	—	—	—	●	—	—
ZP3EA-P5	—	—	—	—	—	●	—	—	—	—	—	—	●	—
ZP3EA-P6	—	—	—	—	—	—	●	—	—	—	—	—	—	●

### ⑤ Pad

Form/Diameter	Flat type with groove (UM)					Bellows type with groove (BM)								
Part no.	32	40	50	63	80	100	125	32	40	50	63	80	100	125
ZP3E-▲UM□	●	●	●	●	●	●	●	—	—	—	—	—	—	—
ZP3E-▲BM□	—	—	—	—	—	—	—	●	●	●	●	●	●	●

Note 1) ▲ in the table indicates the pad diameter.

Note 2) □ in the table indicates the pad material.

### ⑥ Set screw

Form/Diameter	Flat type with groove (UM)					Bellows type with groove (BM)								
Part no.	32	40	50	63	80	100	125	32	40	50	63	80	100	125
ZP3EA-A10	●	●	●	●	●	●	●	●	●	●	●	●	●	●
ZP3EA-A16	—	—	—	—	—	—	—	—	—	—	—	—	—	—

### Mounting nut (Sales unit: 10 pcs.)

Part no.	Mounting thread size	Applicable male thread adapter (①)
ZPNA-M14	M14 x 1	ZP3EA-TAL14
ZPNA-M16	M16 x 1.5	ZP3EA-TAL16

ZP3

ZP3E

ZP2

ZP2V

ZP

ZPT

ZPR

XT661

## With Female Thread Adapter: Vacuum Inlet

ZP3E-T(32 to 50)(UM/BM)□-(B8/B10)  
 ZP3E-T(63 to 125)(UM/BM)□-(B12/B18)

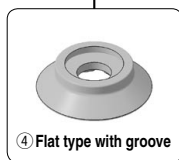
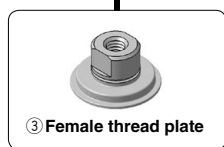
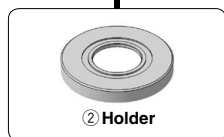
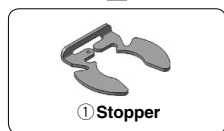
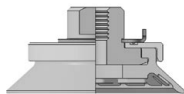

### ① Stopper

Part no.	Form/Diameter						Bellows type with groove (BM)						
	32	40	50	63	80	100	32	40	50	63	80	100	125
ZP3EA-S1	●	●	●	●	●	●	●	●	●	●	●	●	●
ZP3EA-S2	—	—	—	—	—	—	—	—	—	—	—	—	—

### ② Holder

Part no.	Form/Diameter						Bellows type with groove (BM)						
	32	40	50	63	80	100	32	40	50	63	80	100	125
ZP3EA-H1B	●	●	—	—	—	—	●	●	—	—	—	—	—
ZP3EA-H2B	—	—	●	—	—	—	—	—	●	—	—	—	—
ZP3EA-H3B	—	—	—	●	●	—	—	—	—	●	—	—	—
ZP3EA-H4B	—	—	—	—	●	—	—	—	—	—	●	—	—
ZP3EA-H5B	—	—	—	—	—	●	—	—	—	—	—	●	—
ZP3EA-H6B	—	—	—	—	—	—	—	—	—	—	—	—	●

### ③ Female thread plate

Part no.	Mounting thread size	Pad form/diameter												
		Flat type with groove (UM)						Bellows type with groove (BM)						
		32	40	50	63	80	100	32	40	50	63	80	100	125
ZP3EA-PT1-B8	M8	●	●	—	—	—	—	●	●	—	—	—	—	—
ZP3EA-PT1-B10	M10	●	●	—	—	—	—	●	●	—	—	—	—	—
ZP3EA-PT2-B8	M8	—	—	●	—	—	—	—	—	●	—	—	—	—
ZP3EA-PT2-B10	M10	—	—	●	—	—	—	—	—	●	—	—	—	—
ZP3EA-PT3-B12	M12	—	—	—	●	●	—	—	—	—	●	—	—	—
ZP3EA-PT3-B18	M18	—	—	—	●	●	—	—	—	—	●	—	—	—
ZP3EA-PT4-B12	M12	—	—	—	—	●	—	—	—	—	—	●	—	—
ZP3EA-PT4-B18	M18	—	—	—	—	●	—	—	—	—	—	●	—	—
ZP3EA-PT5-B12	M12	—	—	—	—	—	●	—	—	—	—	—	●	—
ZP3EA-PT5-B18	M18	—	—	—	—	—	●	—	—	—	—	—	●	—
ZP3EA-PT6-B12	M12	—	—	—	—	—	—	—	—	—	—	—	—	●
ZP3EA-PT6-B18	M18	—	—	—	—	—	—	—	—	—	—	—	—	●

### ④ Pad

Part no.	Form/Diameter						Bellows type with groove (BM)						
	32	40	50	63	80	100	32	40	50	63	80	100	125
ZP3E-▲UM□	●	●	●	●	●	●	—	—	—	—	—	—	—
ZP3E-▲BM□	—	—	—	—	—	—	●	●	●	●	●	●	●

Note 1) ▲ in the table indicates the pad diameter.

Note 2) □ in the table indicates the pad material.



With Male Thread Adapter/With Female Thread Adapter: Vacuum Inlet Lateral

ZP3E-Y(32 to 50)(UM/BM)□-AL14

ZP3E-Y(63 to 125)(UM/BM)□-AL16

ZP3E-Y(32 to 50)(UM/BM)□-B8  
ZP3E-Y(63 to 125)(UM/BM)□-B12

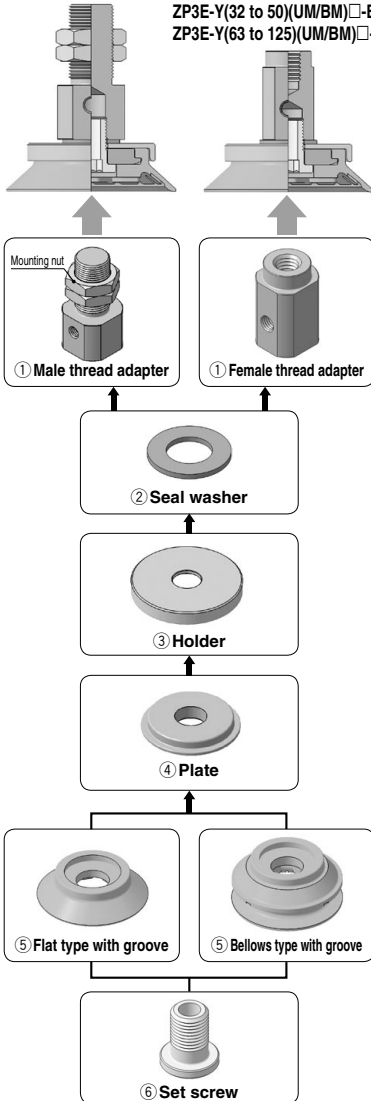

① Male thread adapter (With 2 mounting nuts)

Part no.	Form/Diameter						Flat type with groove (UM)					Bellows type with groove (BM)								
	32	40	50	63	80	100/125	32	40	50	63	80	100	125	32	40	50	63	80	100	125
ZP3EA-YAL14	●	●	●	●	●	●	—	—	—	—	—	—	—	—	—	—	—	—	—	—
ZP3EA-YAL16	—	—	—	●	●	●	—	—	—	—	—	—	—	—	—	—	●	●	●	—

① Female thread adapter

Part no.	Form/Diameter						Flat type with groove (UM)					Bellows type with groove (BM)								
	32	40	50	63	80	100/125	32	40	50	63	80	100	125	32	40	50	63	80	100	125
ZP3EA-YB8	●	●	●	●	●	●	—	—	—	—	—	—	—	—	—	—	—	—	—	—
ZP3EA-YB12	—	—	—	●	●	●	—	—	—	—	—	—	—	—	—	—	●	●	●	—

② Seal washer (Sales unit: 5 pcs.)

Part no.	Mounting thread size	Applicable set screw (⑥)
ZP3EA-SW10	M10 x 1	ZP3EA-A10
ZP3EA-SW16	M16 x 1.5	ZP3EA-A16

③ Holder

Part no.	Form/Diameter						Flat type with groove (UM)					Bellows type with groove (BM)								
	32	40	50	63	80	100/125	32	40	50	63	80	100	125	32	40	50	63	80	100	125
ZP3EA-H1A	●	●	—	—	—	—	—	—	—	—	—	—	—	—	—	—	—	—	—	—
ZP3EA-H2A	—	—	●	—	—	—	—	—	—	—	—	—	—	—	—	—	—	—	—	—
ZP3EA-H3A	—	—	—	●	●	—	—	—	—	—	—	—	—	—	—	—	—	—	—	—
ZP3EA-H4A	—	—	—	—	—	●	—	—	—	—	—	—	—	—	—	—	—	—	—	—
ZP3EA-H5A	—	—	—	—	—	—	—	—	—	—	—	—	●	—	—	—	—	—	—	—
ZP3EA-H6A	—	—	—	—	—	—	—	—	—	—	—	—	—	—	—	—	—	—	—	●

④ Plate

Part no.	Form/Diameter						Flat type with groove (UM)					Bellows type with groove (BM)								
	32	40	50	63	80	100/125	32	40	50	63	80	100	125	32	40	50	63	80	100	125
ZP3EA-P1	●	●	—	—	—	—	—	—	—	—	—	—	—	—	—	—	—	—	—	—
ZP3EA-P2	—	—	●	—	—	—	—	—	—	—	—	—	—	—	—	—	—	—	—	—
ZP3EA-P3	—	—	—	●	●	—	—	—	—	—	—	—	—	—	—	—	—	—	—	—
ZP3EA-P4	—	—	—	—	—	●	—	—	—	—	—	—	—	—	—	—	—	—	—	—
ZP3EA-P5	—	—	—	—	—	—	—	—	—	—	—	—	—	—	—	—	—	—	—	●
ZP3EA-P6	—	—	—	—	—	—	—	—	—	—	—	—	—	—	—	—	—	—	—	●

⑤ Pad

Part no.	Form/Diameter						Flat type with groove (UM)					Bellows type with groove (BM)								
	32	40	50	63	80	100/125	32	40	50	63	80	100	125	32	40	50	63	80	100	125
ZP3E-▲UM□	●	●	●	●	●	●	—	—	—	—	—	—	—	—	—	—	—	—	—	—
ZP3E-▲BM□	—	—	—	—	—	—	—	—	—	—	—	—	—	—	—	—	—	—	—	—

Note 1) ▲ in the table indicates the pad diameter.  
Note 2) □ in the table indicates the pad material.

⑥ Set screw

Part no.	Form/Diameter						Flat type with groove (UM)					Bellows type with groove (BM)								
	32	40	50	63	80	100/125	32	40	50	63	80	100	125	32	40	50	63	80	100	125
ZP3EA-A10	●	●	●	●	●	●	—	—	—	—	—	—	—	—	—	—	—	—	—	—
ZP3EA-A16	—	—	—	●	●	●	—	—	—	—	—	—	—	—	—	—	—	—	—	—

Refer to page 471 for the products that contain ② to ⑥.

Mounting nut (Sales unit: 10 pcs.)

Part no.	Mounting thread size	Applicable male thread adapter (①)
ZPNA-M14	M14 x 1	ZP3EA-YAL14
ZPNA-M16	M16 x 1.5	ZP3EA-YAL16

ZP3

ZP3E

ZP2

ZP2V

ZP

ZPT

ZPR

XT661

With Buffer: Vacuum Inlet



Vacuum inlet: Vertical

Vacuum inlet: Lateral

ZP3E-T(32 to 125)(UM/BM)□JB  
(10/30/50)

ZP3E-Y(32 to 125)(UM/BM)□JB  
(10/30/50)

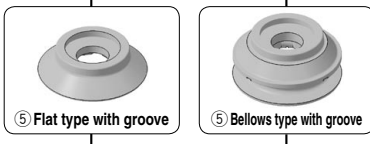
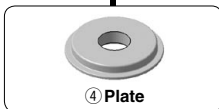
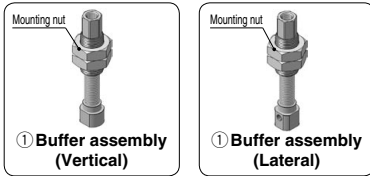
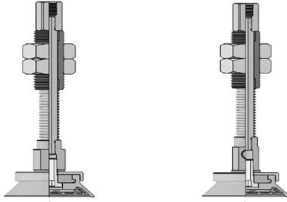

### ① Buffer assembly (With 2 mounting nuts)

Part no.	Form/Diameter						Flat type with groove (UM)					Bellows type with groove (BM)				
	32	40	50	63	80	100	125	32	40	50	63	80	100	125		
ZP3EB-(T/Y)1JB10	●	●	●	●	●	●	—	●	●	●	●	●	●	●		
ZP3EB (T/Y)1JB30	●	●	●	●	●	●	—	●	●	●	●	●	●	●		
ZP3EB-(T/Y)1JB50	—	—	—	—	—	—	—	—	—	—	—	—	—	—		
ZP3EB-(T/Y)2JB10	—	—	—	●	●	●	●	—	—	—	—	—	—	—		
ZP3EB-(T/Y)2JB30	—	—	—	●	●	●	●	—	—	—	—	—	—	—		
ZP3EB-(T/Y)2JB50	—	—	—	●	●	●	●	—	—	—	—	—	—	—		

\* Select "T" when selecting a T type buffer assembly.  
Example) ZP3EB-T1JB10

### ② Seal washer (Sales unit: 5 pcs.)

Part no.	Mounting thread size	Applicable set screw (⑥)
ZP3EA-SW10	M10 x 1	ZP3EA-A10
ZP3EA-SW16	M16 x 1.5	ZP3EA-A16

### ③ Holder

Part no.	Form/Diameter						Flat type with groove (UM)					Bellows type with groove (BM)				
	32	40	50	63	80	100	125	32	40	50	63	80	100	125		
ZP3EA-H1A	●	●	—	—	—	—	—	●	●	—	—	—	—	—		
ZP3EA-H2A	—	—	●	—	—	—	—	—	—	●	—	—	—	—		
ZP3EA-H3A	—	—	—	●	●	—	—	—	—	—	●	—	—	—		
ZP3EA-H4A	—	—	—	—	—	●	—	—	—	—	—	●	—	—		
ZP3EA-H5A	—	—	—	—	—	—	●	—	—	—	—	—	—	●		
ZP3EA-H6A	—	—	—	—	—	—	—	—	—	—	—	—	—	●		

### ④ Plate

Part no.	Form/Diameter						Flat type with groove (UM)					Bellows type with groove (BM)				
	32	40	50	63	80	100	125	32	40	50	63	80	100	125		
ZP3EA-P1	●	●	—	—	—	—	—	—	—	—	—	—	—	—		
ZP3EA-P2	—	—	●	—	—	—	—	—	—	●	—	—	—	—		
ZP3EA-P3	—	—	—	●	●	—	—	—	—	—	●	—	—	—		
ZP3EA-P4	—	—	—	—	—	●	—	—	—	—	—	●	—	—		
ZP3EA-P5	—	—	—	—	—	—	●	—	—	—	—	—	●	—		
ZP3EA-P6	—	—	—	—	—	—	—	—	—	—	—	—	—	●		

### ⑤ Pad

Part no.	Form/Diameter						Flat type with groove (UM)					Bellows type with groove (BM)				
	32	40	50	63	80	100	125	32	40	50	63	80	100	125		
ZP3E-▲UM□	●	●	●	●	●	●	●	—	—	—	—	—	—	—		
ZP3E-▲BM□	—	—	—	—	—	—	—	●	●	●	●	●	●	●		

Note 1) ▲ in the table indicates the pad diameter.  
Note 2) □ in the table indicates the pad material.

### ⑥ Set screw

Part no.	Form/Diameter	Applicable buffer assembly (①)
ZP3EA-A10	—	ZP3EB-(T/Y)1JB (10/30/50)
ZP3EA-A16	—	ZP3EB-(T/Y)2JB (10/30/50)

Refer to page 471 for the products that contain ② to ⑥.

### Mounting nut (Sales unit: 10 pcs.)

Part no.	Mounting thread size	Applicable buffer assembly (①)
ZPNA-M18	M18 x 1.5	ZP3EB-(T/Y)1JB (10/30/50)
ZPNA-M22	M22 x 1.5	ZP3EB-(T/Y)2JB (10/30/50)

With Ball Joint Adapter (for Direct Mounting): Vacuum Inlet 

ZP3E-TF(32 to 125)(UM/BM)□-(AL6/AL12)

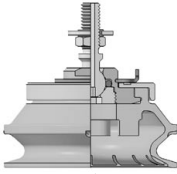

① Stopper

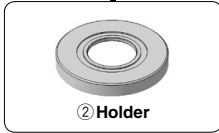

② Holder

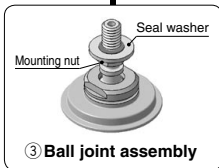

③ Ball joint assembly

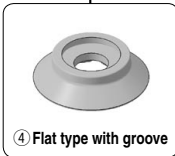

④ Flat type with groove



④ Bellows type with groove

① Stopper

Part no.	Form/Diameter		Flat type with groove (UM)					Bellows type with groove (BM)						
	32	40	50	63	80	100	125	32	40	50	63	80	100	125
ZP3EA-S1	●	●	●	●	●	—	—	●	●	●	●	●	—	—
ZP3EA-S2	—	—	—	—	—	—	—	—	—	—	—	—	—	—

② Holder

Part no.	Form/Diameter		Flat type with groove (UM)					Bellows type with groove (BM)						
	32	40	50	63	80	100	125	32	40	50	63	80	100	125
ZP3EA-H1B	●	●	—	—	—	—	—	●	●	—	—	—	—	—
ZP3EA-H2B	—	—	●	—	—	—	—	—	—	●	—	—	—	—
ZP3EA-H3B	—	—	—	●	●	—	—	—	—	—	●	—	—	—
ZP3EA-H4B	—	—	—	—	—	●	—	—	—	—	—	●	—	—
ZP3EA-H5B	—	—	—	—	—	—	●	—	—	—	—	—	●	—
ZP3EA-H6B	—	—	—	—	—	—	—	—	—	—	—	—	—	●

③ Ball joint assembly (Seal washer and mounting nut: 1 pc. each)

Part no.	Form/Diameter		Flat type with groove (UM)					Bellows type with groove (BM)						
	32	40	50	63	80	100	125	32	40	50	63	80	100	125
ZP3EA-F1-AL6	●	●	—	—	—	—	—	●	●	—	—	—	—	—
ZP3EA-F2-AL6	—	—	●	—	—	—	—	—	—	●	—	—	—	—
ZP3EA-F3-AL12	—	—	—	●	●	—	—	—	—	—	●	—	—	—
ZP3EA-F4-AL12	—	—	—	—	—	●	—	—	—	—	—	●	—	—
ZP3EA-F5-AL12	—	—	—	—	—	—	●	—	—	—	—	—	●	—
ZP3EA-F6-AL12	—	—	—	—	—	—	—	—	—	—	—	—	—	●

④ Pad

Part no.	Form/Diameter		Flat type with groove (UM)					Bellows type with groove (BM)						
	32	40	50	63	80	100	125	32	40	50	63	80	100	125
ZP3E-▲UM□	●	●	●	●	●	●	●	—	—	—	—	—	—	—
ZP3E-▲BM□	—	—	—	—	—	—	—	●	●	●	●	●	●	●

Note 1) ▲ in the table indicates the pad diameter.  
 Note 2) □ in the table indicates the pad material.

Seal washer (Sales unit: 5 pcs.)

Part no.	Mounting thread size	Applicable ball joint assembly (③)
ZP3EA-SW6	M6 x 1	ZP3EA-F(1/2)-AL6
ZP3EA-SW12	M12 x 1.25	ZP3EA-F(3/4/5/6)-AL12

Mounting nut (Sales unit: 10 pcs.)

Part no.	Mounting thread size	Applicable ball joint assembly (③)
ZPNA-M6	M6 x 1	ZP3EA-F(1/2)-AL6
ZPNA-M12	M12 x 1.25	ZP3EA-F(3/4/5/6)-AL12

ZP3

ZP3E

ZP2

ZP2V

ZP

ZPT

ZPR

XT661

## With Ball Joint Female Thread Adapter: Vacuum Inlet

Male thread type

Female thread type

ZP3E-TF(32 to 125)(UM/BM)□  
(AL14/AL16)

ZP3E-TF(32 to 125)(UM/BM)□  
(B8/B12)

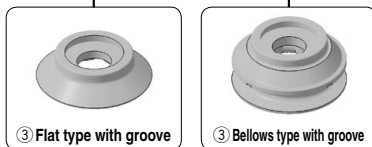
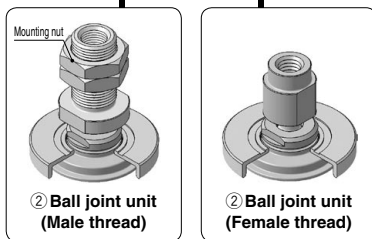
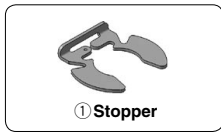
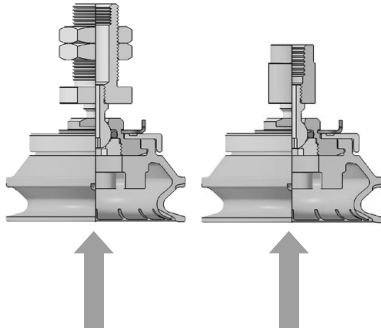

### ① Stopper

Form/Diameter	Flat type with groove (UM)						Bellows type with groove (BM)							
Part no.	32	40	50	63	80	100	125	32	40	50	63	80	100	125
ZP3EA-S1	●	●	●	●	●	●	●	●	●	●	●	●	●	●
ZP3EA-S2	—	—	—	—	—	—	—	—	—	—	—	—	—	—

### ② Ball joint unit (Male thread) (With 2 mounting nuts)

Form/Diameter	Flat type with groove (UM)						Bellows type with groove (BM)							
Part no.	32	40	50	63	80	100	125	32	40	50	63	80	100	125
ZP3EU-F1-TAL14	●	●	—	—	—	—	—	●	●	—	—	—	—	—
ZP3EU-F2-TAL14	—	—	●	—	—	—	—	—	—	●	—	—	—	—
ZP3EU-F3-TAL16	—	—	—	●	●	—	—	—	—	—	●	—	—	—
ZP3EU-F4-TAL16	—	—	—	—	—	●	—	—	—	—	—	●	—	—
ZP3EU-F5-TAL16	—	—	—	—	—	—	●	—	—	—	—	—	●	—
ZP3EU-F6-TAL16	—	—	—	—	—	—	—	—	—	—	—	—	—	●

### ② Ball joint unit (Female thread)

Form/Diameter	Flat type with groove (UM)						Bellows type with groove (BM)							
Part no.	32	40	50	63	80	100	125	32	40	50	63	80	100	125
ZP3EU-F1-TB8	●	●	—	—	—	—	—	●	●	—	—	—	—	—
ZP3EU-F2-TB8	—	—	●	—	—	—	—	—	—	●	—	—	—	—
ZP3EU-F3-TB12	—	—	—	●	●	—	—	—	—	—	●	—	—	—
ZP3EU-F4-TB12	—	—	—	—	—	●	—	—	—	—	—	●	—	—
ZP3EU-F5-TB12	—	—	—	—	—	—	●	—	—	—	—	—	●	—
ZP3EU-F6-TB12	—	—	—	—	—	—	—	—	—	—	—	—	—	●

### ③ Pad

Form/Diameter	Flat type with groove (UM)						Bellows type with groove (BM)							
Part no.	32	40	50	63	80	100	125	32	40	50	63	80	100	125
ZP3E-▲UM□	●	●	●	●	●	●	●	—	—	—	—	—	—	—
ZP3E-▲BM□	—	—	—	—	—	—	—	●	●	●	●	●	●	●

Note 1) ▲ in the table indicates the pad diameter.

Note 2) □ in the table indicates the pad material.

### Mounting nut (Sales unit: 10 pcs.)

Part no.	Mounting thread size	Applicable ball joint unit (Male thread) (2)
ZPNA-M14	M14 x 1	ZP3EU-F(1/2)-TAL14
ZPNA-M16	M16 x 1.5	ZP3EU-F(3/4/5/6)-TAL16

With Ball Joint Male Thread Adapter/Female Thread Adapter: Vacuum Inlet Lateral

**Male thread type**

ZP3E-YF(32 to 125)(UM/BM)□-  
(AL14/AL16)

**Female thread type**

ZP3E-YF(32 to 125)(UM/BM)□-  
(B8/B12)

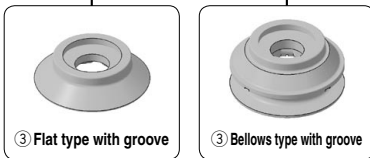
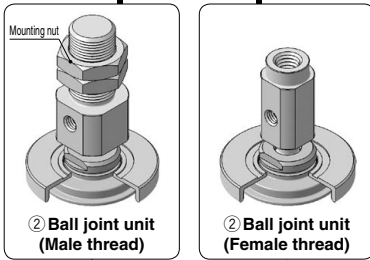
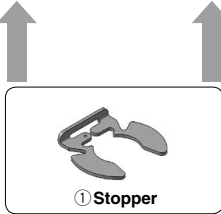
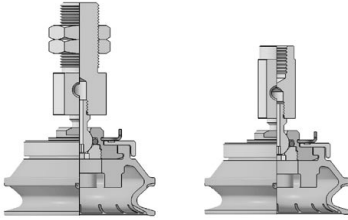

① Stopper

Part no.	Form/Diameter						Flat type with groove (UM)				Bellows type with groove (BM)			
	32	40	50	63	80	100/125	32	40	50	63	80	100/125		
ZP3EA-S1	●	●	●	●	●	●	●	●	●	●	●	●		
ZP3EA-S2	—	—	—	—	—	—	—	—	—	—	—	—		

② Ball joint unit (Male thread) (With 2 mounting nuts)

Part no.	Form/Diameter						Flat type with groove (UM)				Bellows type with groove (BM)			
	32	40	50	63	80	100/125	32	40	50	63	80	100/125		
ZP3EU-F1-YAL14	●	●	—	—	—	—	—	—	●	—	—	—		
ZP3EU-F2-YAL14	—	—	●	—	—	—	—	—	—	●	—	—		
ZP3EU-F3-YAL16	—	—	—	●	●	—	—	—	—	—	●	—		
ZP3EU-F4-YAL16	—	—	—	—	●	—	—	—	—	—	—	●		
ZP3EU-F5-YAL16	—	—	—	—	—	●	—	—	—	—	—	●		
ZP3EU-F6-YAL16	—	—	—	—	—	—	—	—	—	—	—	—		

② Ball joint unit (Female thread)

Part no.	Form/Diameter						Flat type with groove (UM)				Bellows type with groove (BM)			
	32	40	50	63	80	100/125	32	40	50	63	80	100/125		
ZP3EU-F1-YB8	●	●	—	—	—	—	—	—	●	—	—	—		
ZP3EU-F2-YB8	—	—	●	—	—	—	—	—	—	●	—	—		
ZP3EU-F3-YB12	—	—	—	●	●	—	—	—	—	—	●	—		
ZP3EU-F4-YB12	—	—	—	—	●	—	—	—	—	—	—	●		
ZP3EU-F5-YB12	—	—	—	—	—	●	—	—	—	—	—	●		
ZP3EU-F6-YB12	—	—	—	—	—	—	—	—	—	—	—	—		

③ Pad

Part no.	Form/Diameter						Flat type with groove (UM)				Bellows type with groove (BM)			
	32	40	50	63	80	100/125	32	40	50	63	80	100/125		
ZP3E-▲UM□	●	●	●	●	●	●	—	—	—	—	—	—		
ZP3E-▲BM□	—	—	—	—	—	—	●	●	●	●	●	●		

Note 1) ▲ in the table indicates the pad diameter.  
Note 2) □ in the table indicates the pad material.

Mounting nut (Sales unit: 10 pcs.)

Part no.	Mounting thread size	Applicable ball joint unit (Male thread) (2)
ZPNA-M14	M14 x 1	ZP3EU-F(1/2)-YAL14
ZPNA-M16	M16 x 1.5	ZP3EU-F(3/4/5/6)-YAL14

ZP3

ZP3E

ZP2

ZP2V

ZP

ZPT

ZPR

XT661

# ZP3E Series

## With Ball Joint Buffer: Vacuum Inlet Vertical Lateral

Vacuum inlet: Vertical  
Type T

Vacuum inlet: Lateral  
Type Y

ZP3E-TF(32 to 125)(UM/BM)□JB  
(10/30/50)

ZP3E-YF(32 to 125)(UM/BM)□JB  
(10/30/50)

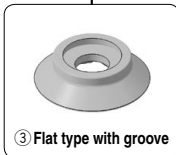
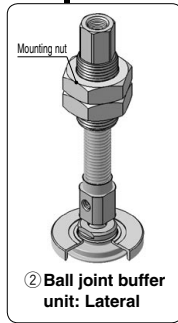
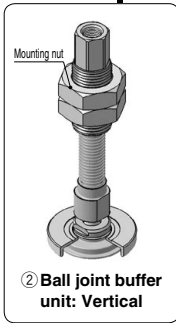
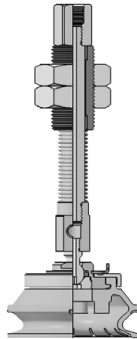
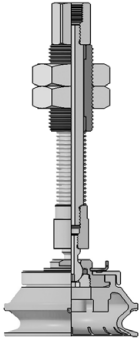

### ① Stopper

Part no.	Form/Diameter						Flat type with groove (UM)				Bellows type with groove (BM)			
	32	40	50	63	80	100	125	32	40	50	63	80	100	125
ZP3EA-S1	●	●	●	●	●	●	●	●	●	●	●	●	●	●
ZP3EA-S2	—	—	—	—	—	—	—	—	—	—	—	—	—	—

### ② Ball joint buffer unit (With 2 mounting nuts)

Part no.	Stroke	Pad form/diameter													
		Flat type with groove (UM)						Bellows type with groove (BM)							
		32	40	50	63	80	100	125	32	40	50	63	80	100	125
ZP3EU-(T/Y)F1JB10	10	●	●	—	—	—	—	—	●	●	—	—	—	—	—
ZP3EU-(T/Y)F1JB30	30	—	—	—	—	—	—	—	—	—	—	—	—	—	—
ZP3EU-(T/Y)F1JB50	50	—	—	—	—	—	—	—	—	—	—	—	—	—	—
ZP3EU-(T/Y)F2JB10	10	—	—	●	—	—	—	—	—	—	●	—	—	—	—
ZP3EU-(T/Y)F2JB30	30	—	—	—	—	—	—	—	—	—	—	—	—	—	—
ZP3EU-(T/Y)F2JB50	50	—	—	—	—	—	—	—	—	—	—	—	—	—	—
ZP3EU-(T/Y)F3JB10	10	—	—	—	—	—	—	—	—	—	—	—	—	—	—
ZP3EU-(T/Y)F3JB30	30	—	—	—	●	●	—	—	—	—	—	●	—	—	—
ZP3EU-(T/Y)F3JB50	50	—	—	—	—	—	—	—	—	—	—	—	—	—	—
ZP3EU-(T/Y)F4JB10	10	—	—	—	—	—	—	—	—	—	—	—	—	—	—
ZP3EU-(T/Y)F4JB30	30	—	—	—	—	—	●	—	—	—	—	—	●	—	—
ZP3EU-(T/Y)F4JB50	50	—	—	—	—	—	—	—	—	—	—	—	—	—	—
ZP3EU-(T/Y)F5JB10	10	—	—	—	—	—	—	—	—	—	—	—	—	—	—
ZP3EU-(T/Y)F5JB30	30	—	—	—	—	—	—	●	—	—	—	—	—	●	—
ZP3EU-(T/Y)F5JB50	50	—	—	—	—	—	—	—	—	—	—	—	—	—	—
ZP3EU-(T/Y)F6JB10	10	—	—	—	—	—	—	—	—	—	—	—	—	—	—
ZP3EU-(T/Y)F6JB30	30	—	—	—	—	—	—	—	—	—	—	—	—	—	—
ZP3EU-(T/Y)F6JB50	50	—	—	—	—	—	—	—	—	—	—	—	—	—	●

\* Select "T" when selecting a T type buffer unit.  
Example) ZP3EU-TF1JB10

### ③ Pad

Part no.	Form/Diameter						Flat type with groove (UM)				Bellows type with groove (BM)			
	32	40	50	63	80	100	125	32	40	50	63	80	100	125
ZP3E-▲UM□	●	●	●	●	●	●	●	—	—	—	—	—	—	—
ZP3E-▲BM□	—	—	—	—	—	—	—	●	●	●	●	●	●	●

Note 1) ▲ in the table indicates the pad diameter.  
Note 2) □ in the table indicates the pad material.

### Mounting nut (Sales unit: 10 pcs.)

Part no.	Mounting thread size	Applicable ball joint buffer unit (②)
ZPNA-M18	M18 x 1.5	ZP3EU-(T/Y)F(1/2)JB(10/30/50)
ZPNA-M22	M22 x 1.5	ZP3EU-(T/Y)F(3/4/5/6)JB(10/30/50)

## How to Replace the Pad

### With Set Screw

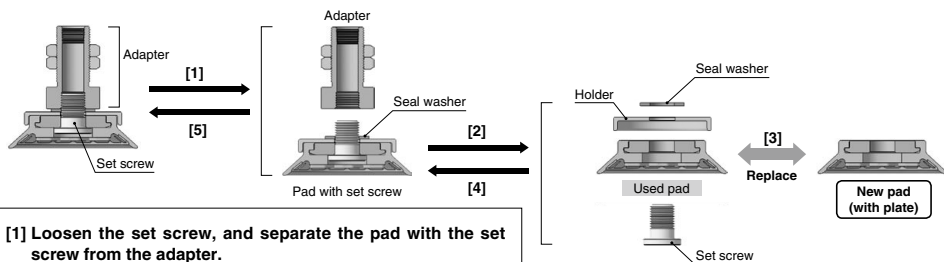

- [1] Loosen the set screw, and separate the pad with the set screw from the adapter.
- [2] Remove the seal washer from the pad with the set screw and separate it into seal washer, holder, pad and set screw. Note 1)
- [3] Replace the pad (with plate) with a new one.
- [4] Insert the set screw from the suction surface side of the new pad, and mount the holder and seal washer in order.
- [5] Mount the adapter onto the set screw. Note 2)

Note 1) When mounting and removing the seal washer, rotate the set screw while the seal washer is being held.

Note 2) Refer to the tightening torque shown in Table 1 for adapter mounting.

Table 1: Recommended Set Screw Tightening Torque

Product specifications			Tightening torque [N·m]
Pad diameter	Product part no.	Mounting thread size	
ø32 to ø50	ZP3E-(32 to 50)UM□□	M10 x 1	8 to 10
	ZP3E-(32 to 50)BM□□		
ø63 to ø125	ZP3E-(63 to 125)UM□□	M16 x 1.5	13 to 15
	ZP3E-(63 to 125)BM□□		

\* Refer to "Pad Unit with Plate" shown below for the replacement method for pads with plate.

### With Stopper (with Female Thread Plate/with Ball Joint Unit)

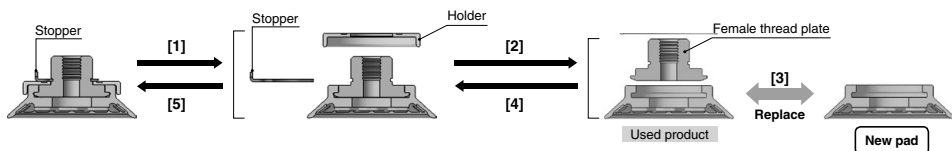

- [1] Pull out the stopper horizontally and remove the holder from the product.
- [2] Remove the female plate.
- [3] Replace the pad with a new one.
- [4] Insert the female thread plate into the new pad.
- [5] Mount the holder and insert the stopper into the specified position.

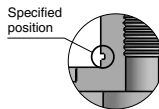

\* Refer to "Pad Unit with Plate" shown below for the replacement method for pads with plate.

### Pad Unit (with Plate)

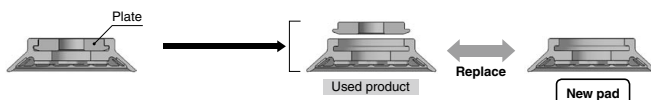

Remove the plate and replace the pad with a new one. Reassemble the product.

\* Press the outer circumference of the plate insertion area by hand to eliminate distortion.

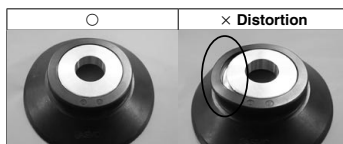

\* The same replacement method is applicable to the replacement of the pad unit with a female thread plate or ball joint unit.

## Component Parts: Dimensions

### Plate

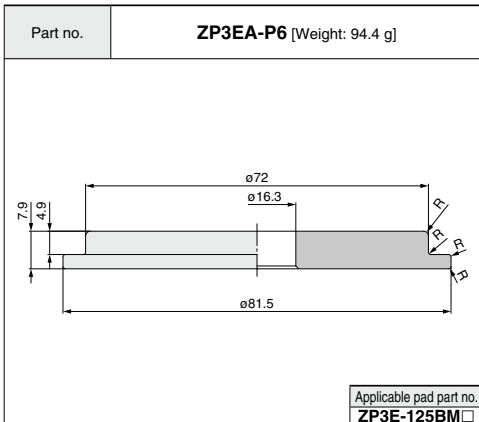
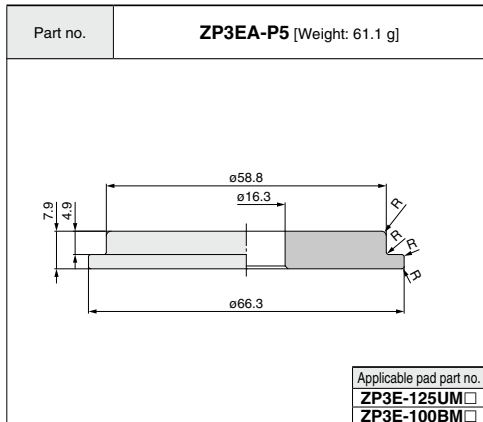
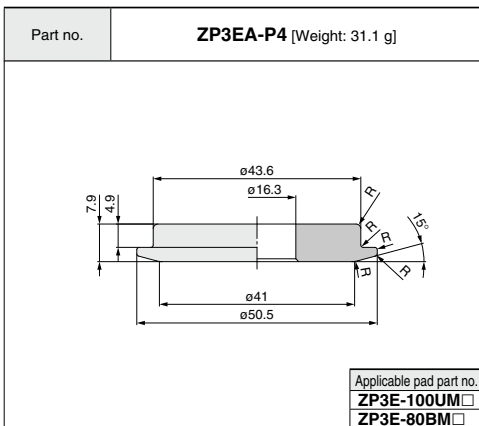
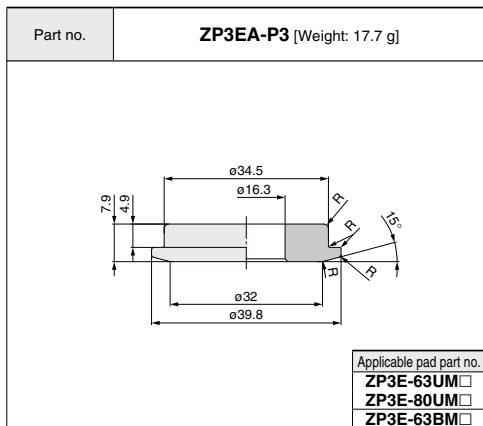
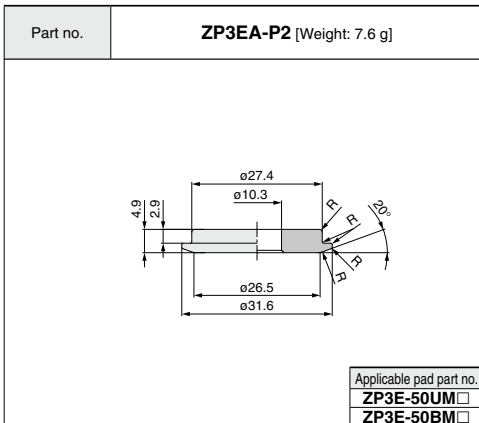
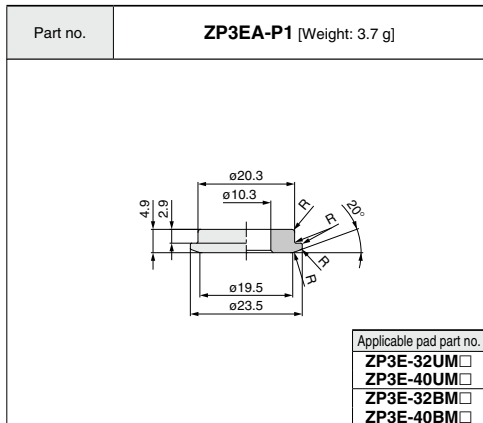



**Holder**

Part no.	<b>ZP3EA-H1A</b> [Weight: 4.5 g]					
<table border="1"> <tr> <td>Applicable pad part no.</td> </tr> <tr> <td>ZP3E-32UM <input type="checkbox"/></td> </tr> <tr> <td>ZP3E-40UM <input type="checkbox"/></td> </tr> <tr> <td>ZP3E-32BM <input type="checkbox"/></td> </tr> <tr> <td>ZP3E-40BM <input type="checkbox"/></td> </tr> </table>		Applicable pad part no.	ZP3E-32UM <input type="checkbox"/>	ZP3E-40UM <input type="checkbox"/>	ZP3E-32BM <input type="checkbox"/>	ZP3E-40BM <input type="checkbox"/>
Applicable pad part no.						
ZP3E-32UM <input type="checkbox"/>						
ZP3E-40UM <input type="checkbox"/>						
ZP3E-32BM <input type="checkbox"/>						
ZP3E-40BM <input type="checkbox"/>						

Part no.	<b>ZP3EA-H2A</b> [Weight: 7 g]			
<table border="1"> <tr> <td>Applicable pad part no.</td> </tr> <tr> <td>ZP3E-50UM <input type="checkbox"/></td> </tr> <tr> <td>ZP3E-50BM <input type="checkbox"/></td> </tr> </table>		Applicable pad part no.	ZP3E-50UM <input type="checkbox"/>	ZP3E-50BM <input type="checkbox"/>
Applicable pad part no.				
ZP3E-50UM <input type="checkbox"/>				
ZP3E-50BM <input type="checkbox"/>				

Part no.	<b>ZP3EA-H3A</b> [Weight: 32.7 g]				
<table border="1"> <tr> <td>Applicable pad part no.</td> </tr> <tr> <td>ZP3E-63UM <input type="checkbox"/></td> </tr> <tr> <td>ZP3E-80UM <input type="checkbox"/></td> </tr> <tr> <td>ZP3E-63BM <input type="checkbox"/></td> </tr> </table>		Applicable pad part no.	ZP3E-63UM <input type="checkbox"/>	ZP3E-80UM <input type="checkbox"/>	ZP3E-63BM <input type="checkbox"/>
Applicable pad part no.					
ZP3E-63UM <input type="checkbox"/>					
ZP3E-80UM <input type="checkbox"/>					
ZP3E-63BM <input type="checkbox"/>					

Part no.	<b>ZP3EA-H4A</b> [Weight: 47.5 g]			
<table border="1"> <tr> <td>Applicable pad part no.</td> </tr> <tr> <td>ZP3E-100UM <input type="checkbox"/></td> </tr> <tr> <td>ZP3E-80BM <input type="checkbox"/></td> </tr> </table>		Applicable pad part no.	ZP3E-100UM <input type="checkbox"/>	ZP3E-80BM <input type="checkbox"/>
Applicable pad part no.				
ZP3E-100UM <input type="checkbox"/>				
ZP3E-80BM <input type="checkbox"/>				

Part no.	<b>ZP3EA-H5A</b> [Weight: 76 g]			
<table border="1"> <tr> <td>Applicable pad part no.</td> </tr> <tr> <td>ZP3E-125UM <input type="checkbox"/></td> </tr> <tr> <td>ZP3E-100BM <input type="checkbox"/></td> </tr> </table>		Applicable pad part no.	ZP3E-125UM <input type="checkbox"/>	ZP3E-100BM <input type="checkbox"/>
Applicable pad part no.				
ZP3E-125UM <input type="checkbox"/>				
ZP3E-100BM <input type="checkbox"/>				

Part no.	<b>ZP3EA-H6A</b> [Weight: 105 g]		
<table border="1"> <tr> <td>Applicable pad part no.</td> </tr> <tr> <td>ZP3E-125BM <input type="checkbox"/></td> </tr> </table>		Applicable pad part no.	ZP3E-125BM <input type="checkbox"/>
Applicable pad part no.			
ZP3E-125BM <input type="checkbox"/>			

**ZP3**

**ZP3E**

**ZP2**

**ZP2V**

**ZP**

**ZPT**

**ZPR**

**XT661**

## Female Thread Plate

Part no.	<b>ZP3EA-PT1-B8</b> [Weight: 9.9 g]	
	<b>ZP3EA-PT1-B10</b> [Weight: 8.5 g]	

Width across flats 14

ø17

17

ø23.5

B

\*1

Part no.	A	B
<b>ZP3EA-PT1-B8</b>	M8 x 1.25	9.5
<b>ZP3EA-PT1-B10</b>	M10 x 1.5	13

Applicable pad part no.	<b>ZP3E-32UM</b> <input type="checkbox"/>
	<b>ZP3E-40UM</b> <input type="checkbox"/>
	<b>ZP3E-32BM</b> <input type="checkbox"/>
	<b>ZP3E-40BM</b> <input type="checkbox"/>

Part no.	<b>ZP3EA-PT2-B8</b> [Weight: 14 g]	
	<b>ZP3EA-PT2-B10</b> [Weight: 12.6 g]	

Width across flats 14

ø17

17

ø31.6

B

\*1

Part no.	A	B
<b>ZP3EA-PT2-B8</b>	M8 x 1.25	9.5
<b>ZP3EA-PT2-B10</b>	M10 x 1.5	13

Applicable pad part no.	<b>ZP3E-50UM</b> <input type="checkbox"/>
	<b>ZP3E-50BM</b> <input type="checkbox"/>

Part no.	<b>ZP3EA-PT3-B12</b> [Weight: 48.6 g]	
	<b>ZP3EA-PT3-B18</b> [Weight: 38.5 g]	

Width across flats 24

ø32

12

24.5

ø39.8

B

\*1

Part no.	A	B
<b>ZP3EA-PT3-B12</b>	M12 x 1.75	12
<b>ZP3EA-PT3-B18</b>	M18 x 1.5	18

Applicable pad part no.	<b>ZP3E-63UM</b> <input type="checkbox"/>
	<b>ZP3E-80UM</b> <input type="checkbox"/>
	<b>ZP3E-63BM</b> <input type="checkbox"/>

Part no.	<b>ZP3EA-PT4-B12</b> [Weight: 62 g]	
	<b>ZP3EA-PT4-B18</b> [Weight: 52 g]	

Width across flats 24

ø32

12

24.5

ø50.5

B

\*1

Part no.	A	B
<b>ZP3EA-PT4-B12</b>	M12 x 1.75	12
<b>ZP3EA-PT4-B18</b>	M18 x 1.5	18

Applicable pad part no.	<b>ZP3E-100UM</b> <input type="checkbox"/>
	<b>ZP3E-80BM</b> <input type="checkbox"/>

Part no.	<b>ZP3EA-PT5-B12</b> [Weight: 92.4 g]	
	<b>ZP3EA-PT5-B18</b> [Weight: 82.4 g]	

Width across flats 24

ø32

12

24.5

ø66.3

B

\*1

Part no.	A	B
<b>ZP3EA-PT5-B12</b>	M12 x 1.75	12
<b>ZP3EA-PT5-B18</b>	M18 x 1.5	18

Applicable pad part no.	<b>ZP3E-125UM</b> <input type="checkbox"/>
	<b>ZP3E-100BM</b> <input type="checkbox"/>

Part no.	<b>ZP3EA-PT6-B12</b> [Weight: 126 g]	
	<b>ZP3EA-PT6-B18</b> [Weight: 116 g]	

Width across flats 24

ø32

12

24.5

ø81.5

B

\*1

Part no.	A	B
<b>ZP3EA-PT6-B12</b>	M12 x 1.75	12
<b>ZP3EA-PT6-B18</b>	M18 x 1.5	18

Applicable pad part no.	<b>ZP3E-125BM</b> <input type="checkbox"/>
-------------------------	--

\*1 Refer to page 480 for detailed dimensions.

**Holder (for Female thread plate/Ball joint)**

Part no.	<b>ZP3EA-H1B</b> [Weight: 3.6 g]					
<table border="1"> <tr> <td>Applicable pad part no.</td> </tr> <tr> <td>ZP3E-32UM <input type="checkbox"/></td> </tr> <tr> <td>ZP3E-40UM <input type="checkbox"/></td> </tr> <tr> <td>ZP3E-32BM <input type="checkbox"/></td> </tr> <tr> <td>ZP3E-40BM <input type="checkbox"/></td> </tr> </table>		Applicable pad part no.	ZP3E-32UM <input type="checkbox"/>	ZP3E-40UM <input type="checkbox"/>	ZP3E-32BM <input type="checkbox"/>	ZP3E-40BM <input type="checkbox"/>
Applicable pad part no.						
ZP3E-32UM <input type="checkbox"/>						
ZP3E-40UM <input type="checkbox"/>						
ZP3E-32BM <input type="checkbox"/>						
ZP3E-40BM <input type="checkbox"/>						

Part no.	<b>ZP3EA-H2B</b> [Weight: 6.1 g]			
<table border="1"> <tr> <td>Applicable pad part no.</td> </tr> <tr> <td>ZP3E-50UM <input type="checkbox"/></td> </tr> <tr> <td>ZP3E-50BM <input type="checkbox"/></td> </tr> </table>		Applicable pad part no.	ZP3E-50UM <input type="checkbox"/>	ZP3E-50BM <input type="checkbox"/>
Applicable pad part no.				
ZP3E-50UM <input type="checkbox"/>				
ZP3E-50BM <input type="checkbox"/>				

Part no.	<b>ZP3EA-H3B</b> [Weight: 12.1 g]				
<table border="1"> <tr> <td>Applicable pad part no.</td> </tr> <tr> <td>ZP3E-63UM <input type="checkbox"/></td> </tr> <tr> <td>ZP3E-80UM <input type="checkbox"/></td> </tr> <tr> <td>ZP3E-63BM <input type="checkbox"/></td> </tr> </table>		Applicable pad part no.	ZP3E-63UM <input type="checkbox"/>	ZP3E-80UM <input type="checkbox"/>	ZP3E-63BM <input type="checkbox"/>
Applicable pad part no.					
ZP3E-63UM <input type="checkbox"/>					
ZP3E-80UM <input type="checkbox"/>					
ZP3E-63BM <input type="checkbox"/>					

Part no.	<b>ZP3EA-H4B</b> [Weight: 18.4 g]			
<table border="1"> <tr> <td>Applicable pad part no.</td> </tr> <tr> <td>ZP3E-100UM <input type="checkbox"/></td> </tr> <tr> <td>ZP3E-80BM <input type="checkbox"/></td> </tr> </table>		Applicable pad part no.	ZP3E-100UM <input type="checkbox"/>	ZP3E-80BM <input type="checkbox"/>
Applicable pad part no.				
ZP3E-100UM <input type="checkbox"/>				
ZP3E-80BM <input type="checkbox"/>				

Part no.	<b>ZP3EA-H5B</b> [Weight: 31 g]			
<table border="1"> <tr> <td>Applicable pad part no.</td> </tr> <tr> <td>ZP3E-125UM <input type="checkbox"/></td> </tr> <tr> <td>ZP3E-100BM <input type="checkbox"/></td> </tr> </table>		Applicable pad part no.	ZP3E-125UM <input type="checkbox"/>	ZP3E-100BM <input type="checkbox"/>
Applicable pad part no.				
ZP3E-125UM <input type="checkbox"/>				
ZP3E-100BM <input type="checkbox"/>				

Part no.	<b>ZP3EA-H6B</b> [Weight: 44.2 g]		
<table border="1"> <tr> <td>Applicable pad part no.</td> </tr> <tr> <td>ZP3E-125BM <input type="checkbox"/></td> </tr> </table>		Applicable pad part no.	ZP3E-125BM <input type="checkbox"/>
Applicable pad part no.			
ZP3E-125BM <input type="checkbox"/>			

ZP3

ZP3E

ZP2

ZP2V

ZP

ZPT  
ZPR

XT661

# ZP3E Series

## Set Screw

Part no.	<b>ZP3EA-A10</b> [Weight: 8.7 g]
----------	----------------------------------

Applicable pad part no.
ZP3E-32UM <input type="checkbox"/>
ZP3E-40UM <input type="checkbox"/>
ZP3E-50UM <input type="checkbox"/>
ZP3E-32BM <input type="checkbox"/>
ZP3E-40BM <input type="checkbox"/>
ZP3E-50BM <input type="checkbox"/>

Part no.	<b>ZP3EA-A16</b> [Weight: 25.9 g]
----------	-----------------------------------

Applicable pad part no.
ZP3E-63UM <input type="checkbox"/>
ZP3E-80UM <input type="checkbox"/>
ZP3E-100UM <input type="checkbox"/>
ZP3E-125UM <input type="checkbox"/>
ZP3E-63BM <input type="checkbox"/>
ZP3E-80BM <input type="checkbox"/>
ZP3E-100BM <input type="checkbox"/>
ZP3E-125BM <input type="checkbox"/>

## Male Thread Adapter (Vacuum inlet: Vertical)

Part no.	<b>ZP3EA-TAL14</b> [Weight: 27.0 g]
----------	-------------------------------------

Applicable pad part no.
ZP3E-32UM <input type="checkbox"/>
ZP3E-40UM <input type="checkbox"/>
ZP3E-50UM <input type="checkbox"/>
ZP3E-32BM <input type="checkbox"/>
ZP3E-40BM <input type="checkbox"/>
ZP3E-50BM <input type="checkbox"/>

Part no.	<b>ZP3EA-TAL16</b> [Weight: 99.8 g]
----------	-------------------------------------

Applicable pad part no.
ZP3E-63UM <input type="checkbox"/>
ZP3E-80UM <input type="checkbox"/>
ZP3E-100UM <input type="checkbox"/>
ZP3E-125UM <input type="checkbox"/>
ZP3E-63BM <input type="checkbox"/>
ZP3E-80BM <input type="checkbox"/>
ZP3E-100BM <input type="checkbox"/>
ZP3E-125BM <input type="checkbox"/>

## Male Thread Adapter (Vacuum inlet: Lateral)

Part no.	<b>ZP3EA-YAL14</b> [Weight: 36.3 g]
----------	-------------------------------------

Applicable pad part no.
ZP3E-32UM <input type="checkbox"/>
ZP3E-40UM <input type="checkbox"/>
ZP3E-50UM <input type="checkbox"/>
ZP3E-32BM <input type="checkbox"/>
ZP3E-40BM <input type="checkbox"/>
ZP3E-50BM <input type="checkbox"/>

Part no.	<b>ZP3EA-YAL16</b> [Weight: 116.6 g]
----------	--------------------------------------

Applicable pad part no.
ZP3E-63UM <input type="checkbox"/>
ZP3E-80UM <input type="checkbox"/>
ZP3E-100UM <input type="checkbox"/>
ZP3E-125UM <input type="checkbox"/>
ZP3E-63BM <input type="checkbox"/>
ZP3E-80BM <input type="checkbox"/>
ZP3E-100BM <input type="checkbox"/>
ZP3E-125BM <input type="checkbox"/>

**Female Thread Adapter (Vacuum inlet: Lateral)**

Part no.	<b>ZP3EA-YB8</b> [Weight: 15 g]
----------	---------------------------------

M5 x 0.8/  
Effective thread depth 5

Applicable pad part no.
ZP3E-32UM <input type="checkbox"/>
ZP3E-40UM <input type="checkbox"/>
ZP3E-50UM <input type="checkbox"/>
ZP3E-32BM <input type="checkbox"/>
ZP3E-40BM <input type="checkbox"/>
ZP3E-50BM <input type="checkbox"/>

Part no.	<b>ZP3EA-YB12</b> [Weight: 42.3 g]
----------	------------------------------------

Applicable pad part no.
ZP3E-63UM <input type="checkbox"/>
ZP3E-80UM <input type="checkbox"/>
ZP3E-100UM <input type="checkbox"/>
ZP3E-125UM <input type="checkbox"/>
ZP3E-63BM <input type="checkbox"/>
ZP3E-80BM <input type="checkbox"/>
ZP3E-100BM <input type="checkbox"/>
ZP3E-125BM <input type="checkbox"/>

**Stopper**

Part no.	<b>ZP3EA-S1</b> [Weight: 2.9 g]
----------	---------------------------------

Applicable pad part no.
ZP3E-32UM <input type="checkbox"/>
ZP3E-40UM <input type="checkbox"/>
ZP3E-50UM <input type="checkbox"/>
ZP3E-32BM <input type="checkbox"/>
ZP3E-40BM <input type="checkbox"/>
ZP3E-50BM <input type="checkbox"/>

Part no.	<b>ZP3EA-S2</b> [Weight: 7.6 g]
----------	---------------------------------

Applicable pad part no.
ZP3E-63UM <input type="checkbox"/>
ZP3E-80UM <input type="checkbox"/>
ZP3E-100UM <input type="checkbox"/>
ZP3E-125UM <input type="checkbox"/>
ZP3E-63BM <input type="checkbox"/>
ZP3E-80BM <input type="checkbox"/>
ZP3E-100BM <input type="checkbox"/>
ZP3E-125BM <input type="checkbox"/>

**Seal Washer**

Part no.	<b>ZP3EA-SW6</b> [Weight: 1.0 g]
	<b>ZP3EA-SW10</b> [Weight: 1.1 g]
	<b>ZP3EA-SW12</b> [Weight: 4.2 g]
	<b>ZP3EA-SW16</b> [Weight: 5.2 g]

(Sales unit: 5 pcs.)

Material: Core sheet—Rolled steel  
Seal—NBR

**Dimensions**

Part no.	t	D	Applicable thread size
ZP3EA-SW6	1.3	14	M6 x 1
ZP3EA-SW10	1.6	15.5	M10 x 1
ZP3EA-SW12	2	24.3	M12 x 1.25
ZP3EA-SW16	2	28	M16 x 1.5

**Mounting Nut**

Part no.	<b>ZPNA-M6</b> [Weight: 0.7 g]
	<b>ZPNA-M12</b> [Weight: 8.0 g]
	<b>ZPNA-M14</b> [Weight: 6.6 g]
	<b>ZPNA-M16</b> [Weight: 10.1 g]
	<b>ZPNA-M18</b> [Weight: 26.4 g]
	<b>ZPNA-M22</b> [Weight: 24.7 g]

**Dimensions**

Part no.	d	B	H	Sales unit
ZPNA-M6	M6 x 1	8	3	10 pcs.
ZPNA-M12	M12 x 1.25	19	7	
ZPNA-M14	M14 x 1	19	5	
ZPNA-M16	M16 x 1.5	22	6	2 pcs.
ZPNA-M18	M18 x 1.5	27	9	
ZPNA-M22	M22 x 1.5	30	8	

ZP3

ZP3E

ZP2

ZP2V

ZP

ZPT

ZPR

XT661

# ZP3E Series

## Buffer Assembly (Vacuum inlet: Vertical)

Part no.	<b>ZP3EB-T1JB10</b> [Weight: 172 g]
	<b>ZP3EB-T1JB30</b> [Weight: 187 g]
	<b>ZP3EB-T1JB50</b> [Weight: 198 g]

**Dimensions**

Part no.	A	B
ZP3EB-T1JB10	47.5	99.5
ZP3EB-T1JB30	72.5	124.5
ZP3EB-T1JB50	92.5	144.5

Applicable pad part no.

ZP3E-32UM	<input type="checkbox"/>
ZP3E-40UM	<input type="checkbox"/>
ZP3E-50UM	<input type="checkbox"/>
ZP3E-32BM	<input type="checkbox"/>
ZP3E-40BM	<input type="checkbox"/>
ZP3E-50BM	<input type="checkbox"/>

Part no.	<b>ZP3EB-T2JB10</b> [Weight: 308 g]
	<b>ZP3EB-T2JB30</b> [Weight: 337 g]
	<b>ZP3EB-T2JB50</b> [Weight: 360 g]

**Dimensions**

Part no.	A	B
ZP3EB-T2JB10	58	128
ZP3EB-T2JB30	83	153
ZP3EB-T2JB50	103	173

Applicable pad part no.

ZP3E-63UM	<input type="checkbox"/>
ZP3E-80UM	<input type="checkbox"/>
ZP3E-100UM	<input type="checkbox"/>
ZP3E-125UM	<input type="checkbox"/>
ZP3E-63BM	<input type="checkbox"/>
ZP3E-80BM	<input type="checkbox"/>
ZP3E-100BM	<input type="checkbox"/>
ZP3E-125BM	<input type="checkbox"/>

## Buffer Assembly (Vacuum inlet: Lateral)

Part no.	<b>ZP3EB-Y1JB10</b> [Weight: 170 g]
	<b>ZP3EB-Y1JB30</b> [Weight: 186 g]
	<b>ZP3EB-Y1JB50</b> [Weight: 196 g]

**Dimensions**

Part no.	A	B
ZP3EB-Y1JB10	50.5	94.5
ZP3EB-Y1JB30	75.5	119.5
ZP3EB-Y1JB50	95.5	139.5

Applicable pad part no.

ZP3E-32UM	<input type="checkbox"/>
ZP3E-40UM	<input type="checkbox"/>
ZP3E-50UM	<input type="checkbox"/>
ZP3E-32BM	<input type="checkbox"/>
ZP3E-40BM	<input type="checkbox"/>
ZP3E-50BM	<input type="checkbox"/>

Part no.	<b>ZP3EB-Y2JB10</b> [Weight: 306 g]
	<b>ZP3EB-Y2JB30</b> [Weight: 337 g]
	<b>ZP3EB-Y2JB50</b> [Weight: 362 g]

**Dimensions**

Part no.	A	B
ZP3EB-Y2JB10	65	125
ZP3EB-Y2JB30	90	150
ZP3EB-Y2JB50	110	170

Applicable pad part no.

ZP3E-63UM	<input type="checkbox"/>
ZP3E-80UM	<input type="checkbox"/>
ZP3E-100UM	<input type="checkbox"/>
ZP3E-125UM	<input type="checkbox"/>
ZP3E-63BM	<input type="checkbox"/>
ZP3E-80BM	<input type="checkbox"/>
ZP3E-100BM	<input type="checkbox"/>
ZP3E-125BM	<input type="checkbox"/>

# ZP3E Series

# Ball Joint Assembly/Unit Part No.

## Ball Joint Assembly

Part no.	<b>ZP3EA-F1-AL6</b> [Weight: 27.3 g]
----------	--------------------------------------

Applicable pad part no.
<b>ZP3E-32UM</b> <input type="checkbox"/>
<b>ZP3E-40UM</b> <input type="checkbox"/>
<b>ZP3E-32BM</b> <input type="checkbox"/>
<b>ZP3E-40BM</b> <input type="checkbox"/>

Part no.	<b>ZP3EA-F2-AL6</b> [Weight: 38.7 g]
----------	--------------------------------------

Applicable pad part no.
<b>ZP3E-50UM</b> <input type="checkbox"/>
<b>ZP3E-50BM</b> <input type="checkbox"/>

Part no.	<b>ZP3EA-F3-AL12</b> [Weight: 109 g]
----------	--------------------------------------

Applicable pad part no.
<b>ZP3E-63UM</b> <input type="checkbox"/>
<b>ZP3E-80UM</b> <input type="checkbox"/>
<b>ZP3E-63BM</b> <input type="checkbox"/>

Part no.	<b>ZP3EA-F4-AL12</b> [Weight: 122 g]
----------	--------------------------------------

Applicable pad part no.
<b>ZP3E-100UM</b> <input type="checkbox"/>
<b>ZP3E-80BM</b> <input type="checkbox"/>

Part no.	<b>ZP3EA-F5-AL12</b> [Weight: 153 g]
----------	--------------------------------------

Applicable pad part no.
<b>ZP3E-125UM</b> <input type="checkbox"/>
<b>ZP3E-100BM</b> <input type="checkbox"/>

Part no.	<b>ZP3EA-F6-AL12</b> [Weight: 186 g]
----------	--------------------------------------

Applicable pad part no.
<b>ZP3E-125BM</b> <input type="checkbox"/>

ZP3

ZP3E

ZP2

ZP2V

ZP

ZPT

ZPR

XT661

\*1) Center of the rotating angle

## Ball Joint Unit: Male Thread (Vacuum inlet: Vertical)

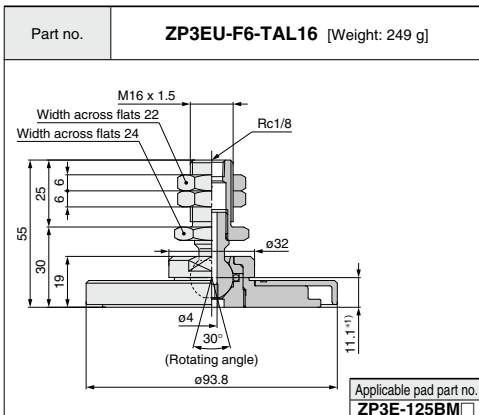
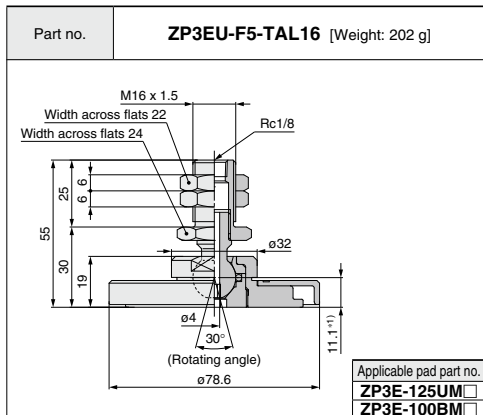
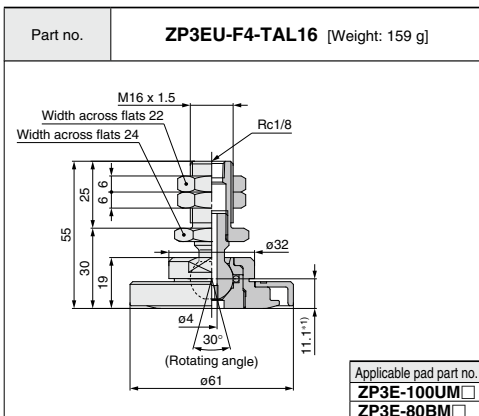
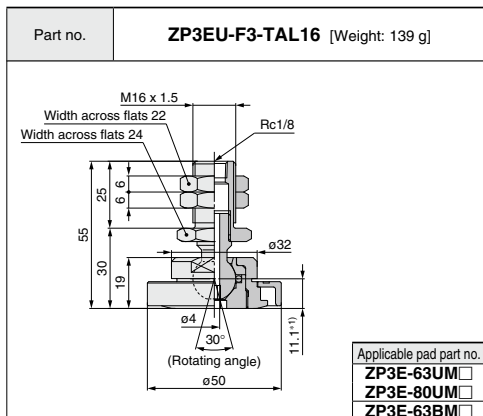
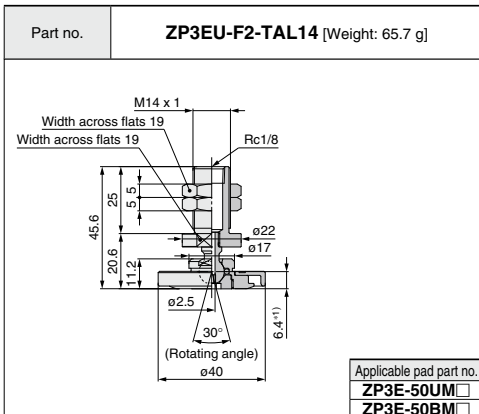
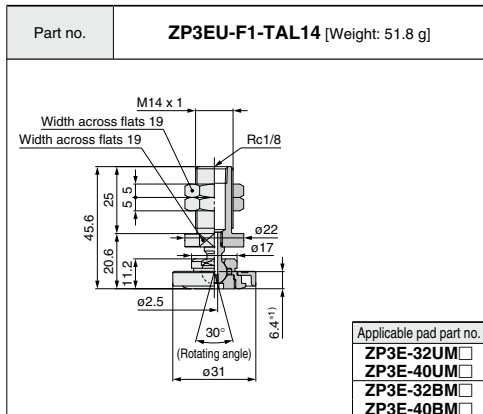

\*1) Center of the rotating angle



**Ball Joint Unit: Female Thread (Vacuum inlet: Vertical)**

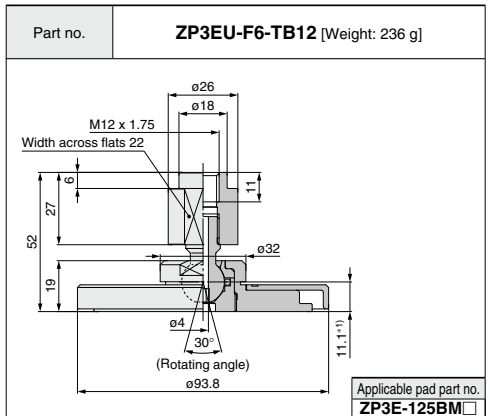
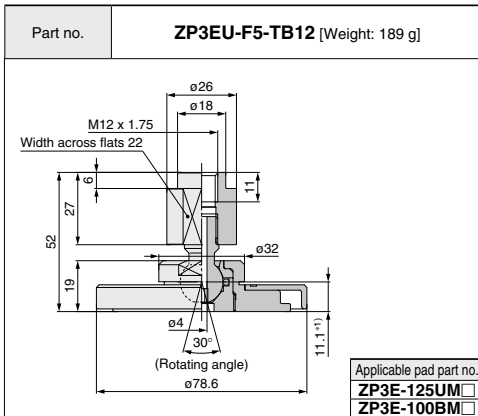
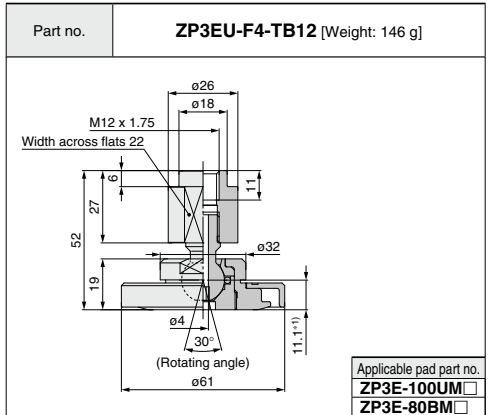
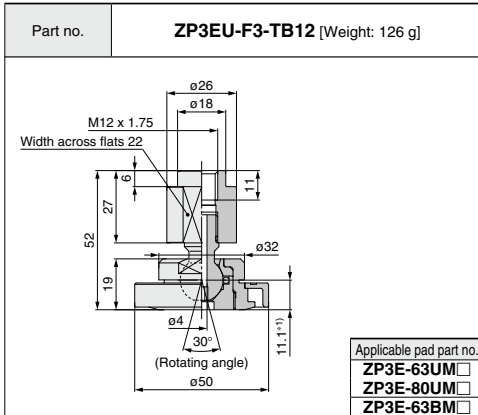
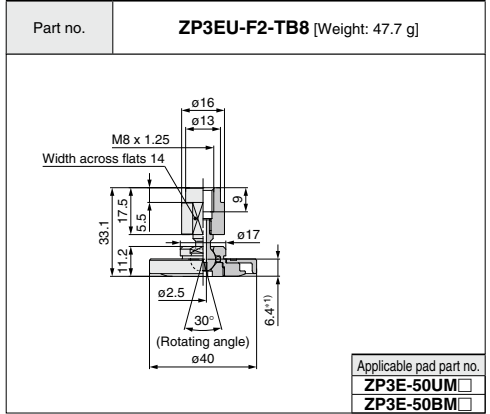
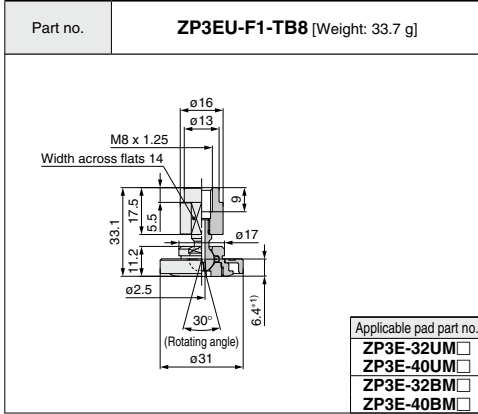

\*1) Center of the rotating angle

**ZP3**

**ZP3E**

**ZP2**

**ZP2V**

**ZP**

**ZPT**

**ZPR**

**XT661**

## Ball Joint Unit: Male Thread (Vacuum inlet: Lateral)

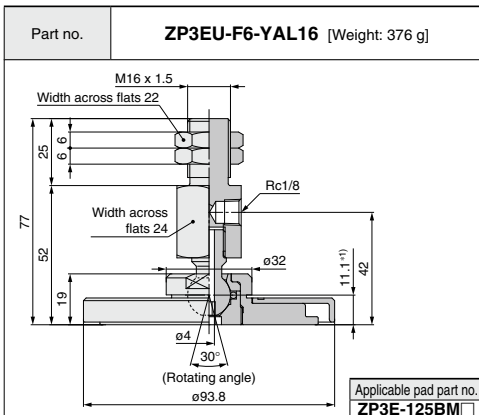
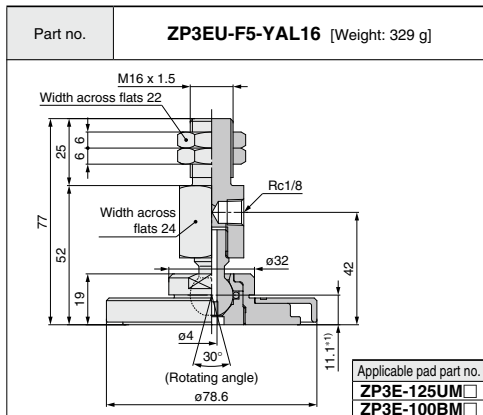
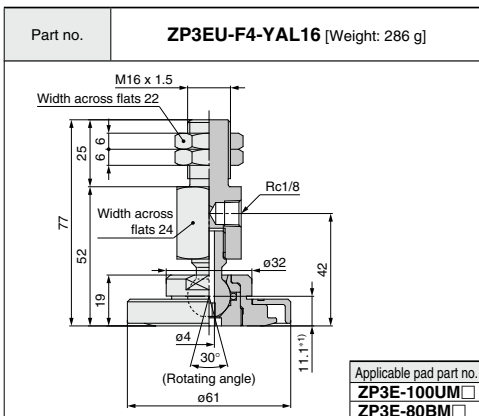
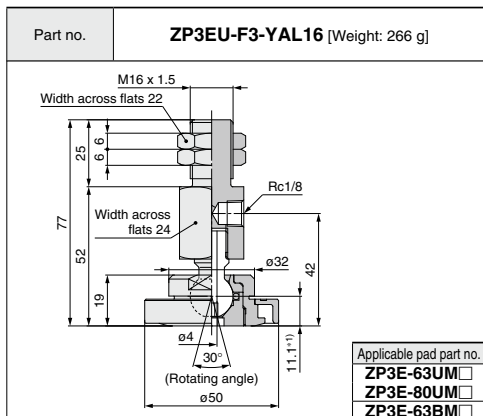
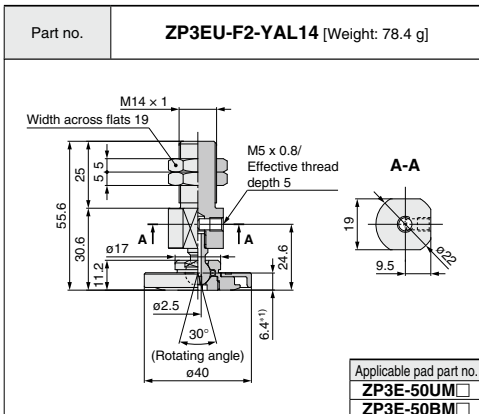
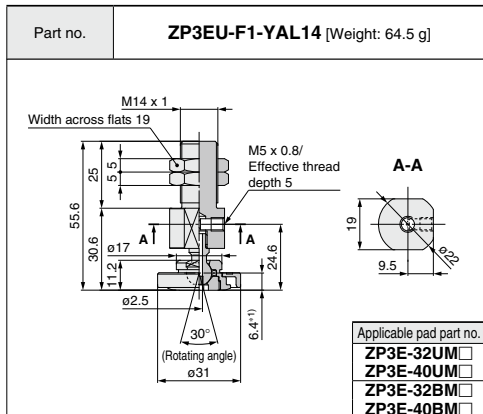

\*1) Center of the rotating angle

## Ball Joint Unit: Female Thread (Vacuum inlet: Lateral)

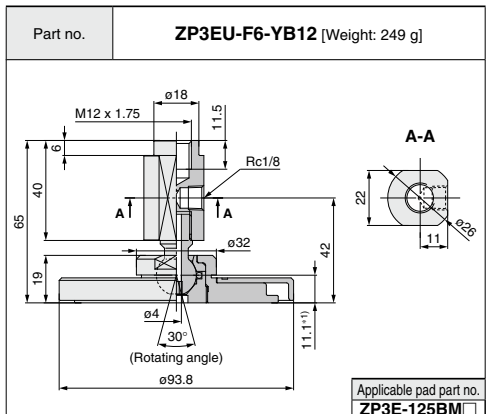
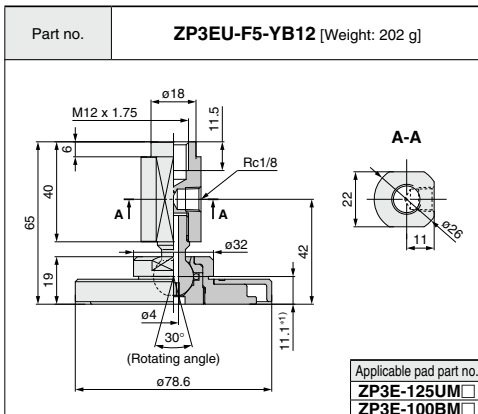
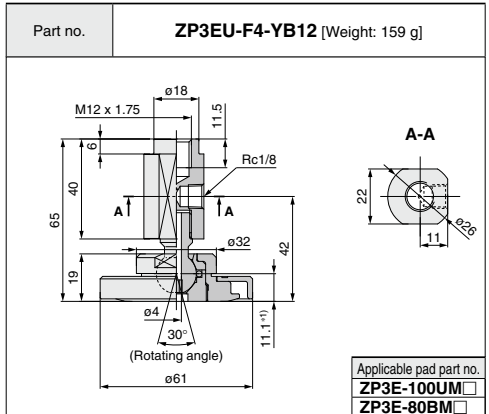
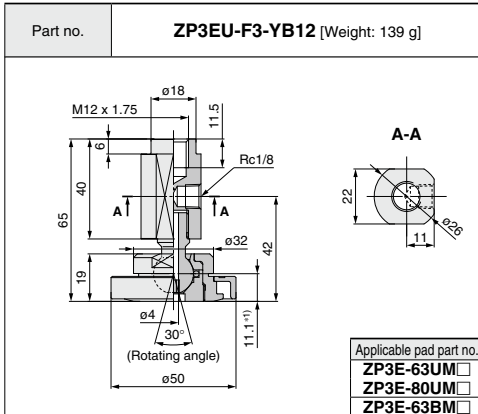
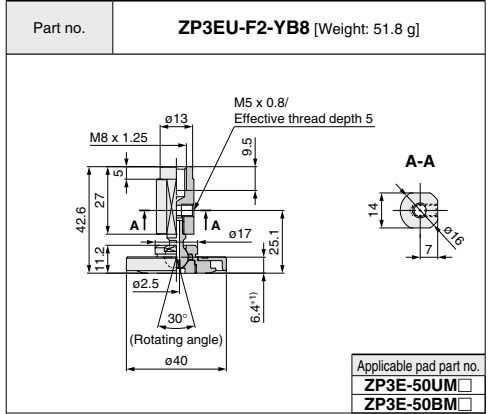
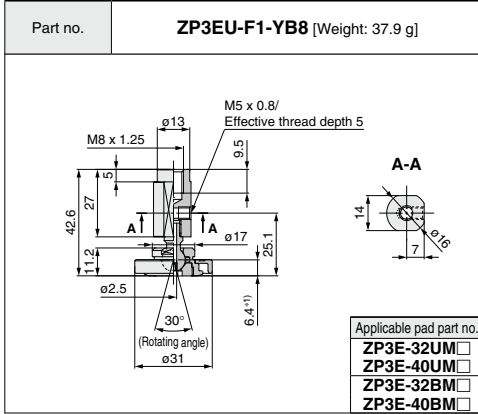

\*1) Center of the rotating angle

**ZP3**

**ZP3E**

**ZP2**

**ZP2V**

**ZP**

**ZPT**

**ZPR**

**XT661**

# ZP3E Series

# Ball Joint Buffer Unit Part No.

## Ball Joint Buffer Unit (Vacuum inlet: Vertical)

Part no.	ZP3EU-TF1JB10 [Weight: 202 g]
	ZP3EU-TF1JB30 [Weight: 211 g]
	ZP3EU-TF1JB50 [Weight: 223 g]

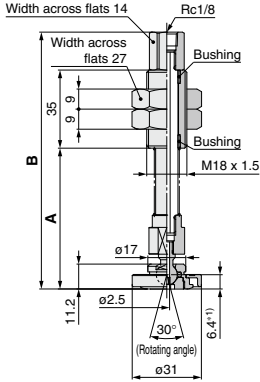

### Dimensions

Part no.	A	B
ZP3EU-TF1JB10	63.1	115.1
ZP3EU-TF1JB30	88.1	140.1
ZP3EU-TF1JB50	108.1	160.1

### Applicable pad part no.

ZP3E-32UM	<input type="checkbox"/>
ZP3E-40UM	<input type="checkbox"/>
ZP3E-32BM	<input type="checkbox"/>
ZP3E-40BM	<input type="checkbox"/>

Part no.	ZP3EU-TF2JB10 [Weight: 211 g]
	ZP3EU-TF2JB30 [Weight: 225 g]
	ZP3EU-TF2JB50 [Weight: 237 g]

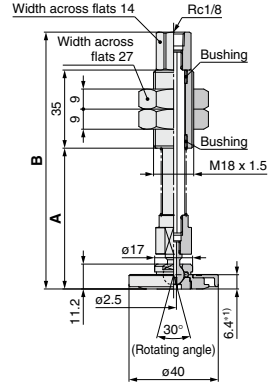

### Dimensions

Part no.	A	B
ZP3EU-TF2JB10	63.1	115.1
ZP3EU-TF2JB30	88.1	140.1
ZP3EU-TF2JB50	108.1	160.1

### Applicable pad part no.

ZP3E-50UM	<input type="checkbox"/>
ZP3E-50BM	<input type="checkbox"/>

Part no.	ZP3EU-TF3JB10 [Weight: 409 g]
	ZP3EU-TF3JB30 [Weight: 438 g]
	ZP3EU-TF3JB50 [Weight: 461 g]

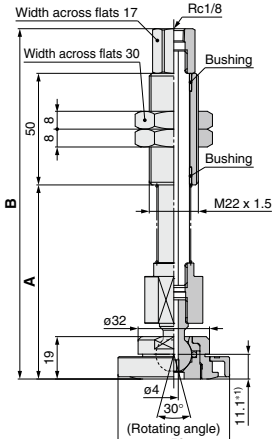

### Dimensions

Part no.	A	B
ZP3EU-TF3JB10	87	157
ZP3EU-TF3JB30	112	182
ZP3EU-TF3JB50	132	202

### Applicable pad part no.

ZP3E-63UM	<input type="checkbox"/>
ZP3E-80UM	<input type="checkbox"/>
ZP3E-63BM	<input type="checkbox"/>

Part no.	ZP3EU-TF4JB10 [Weight: 429 g]
	ZP3EU-TF4JB30 [Weight: 458 g]
	ZP3EU-TF4JB50 [Weight: 481 g]

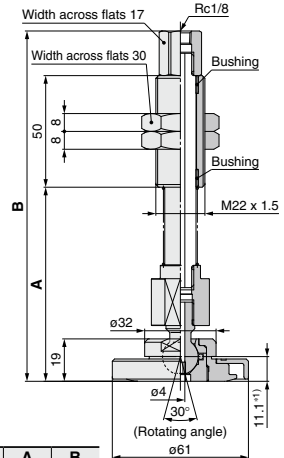

### Dimensions

Part no.	A	B
ZP3EU-TF4JB10	87	157
ZP3EU-TF4JB30	112	182
ZP3EU-TF4JB50	132	202

### Applicable pad part no.

ZP3E-100UM	<input type="checkbox"/>
ZP3E-80BM	<input type="checkbox"/>

\*1) Center of the rotating angle

## Ball Joint Buffer Unit (Vacuum inlet: Vertical)

Part no.	<b>ZP3EU-TF5JB10</b> [Weight: 472 g]
	<b>ZP3EU-TF5JB30</b> [Weight: 501 g]
	<b>ZP3EU-TF5JB50</b> [Weight: 524 g]

Dimensions		
Part no.	A	B
<b>ZP3EU-TF5JB10</b>	87	157
<b>ZP3EU-TF5JB30</b>	112	182
<b>ZP3EU-TF5JB50</b>	132	202

Applicable pad part no.	
<b>ZP3E-125UM</b> <input type="checkbox"/>	
<b>ZP3E-100BM</b> <input type="checkbox"/>	

Part no.	<b>ZP3EU-TF6JB10</b> [Weight: 519 g]
	<b>ZP3EU-TF6JB30</b> [Weight: 548 g]
	<b>ZP3EU-TF6JB50</b> [Weight: 571 g]

Dimensions		
Part no.	A	B
<b>ZP3EU-TF6JB10</b>	87	157
<b>ZP3EU-TF6JB30</b>	112	182
<b>ZP3EU-TF6JB50</b>	132	202

Applicable pad part no.	
<b>ZP3E-125BM</b> <input type="checkbox"/>	

## Ball Joint Buffer Unit (Vacuum inlet: Lateral)

Part no.	<b>ZP3EU-YF1JB10</b> [Weight: 195 g]
	<b>ZP3EU-YF1JB30</b> [Weight: 211 g]
	<b>ZP3EU-YF1JB50</b> [Weight: 224 g]

Dimensions		
Part no.	A	B
<b>ZP3EU-YF1JB10</b>	66.1	111.1
<b>ZP3EU-YF1JB30</b>	91.1	135.1
<b>ZP3EU-YF1JB50</b>	111.1	155.1

Applicable pad part no.	
<b>ZP3E-32UM</b> <input type="checkbox"/>	
<b>ZP3E-40UM</b> <input type="checkbox"/>	
<b>ZP3E-32BM</b> <input type="checkbox"/>	
<b>ZP3E-40BM</b> <input type="checkbox"/>	

Part no.	<b>ZP3EU-YF2JB10</b> [Weight: 209 g]
	<b>ZP3EU-YF2JB30</b> [Weight: 225 g]
	<b>ZP3EU-YF2JB50</b> [Weight: 237 g]

Dimensions		
Part no.	A	B
<b>ZP3EU-YF2JB10</b>	66.1	111.1
<b>ZP3EU-YF2JB30</b>	91.1	135.1
<b>ZP3EU-YF2JB50</b>	111.1	155.1

Applicable pad part no.	
<b>ZP3E-50UM</b> <input type="checkbox"/>	
<b>ZP3E-50BM</b> <input type="checkbox"/>	

\*1) Center of the rotating angle

## Ball Joint Buffer Unit (Vacuum inlet: Lateral)

Part no.	<b>ZP3EU-YF3JB10</b> [Weight: 410 g]
	<b>ZP3EU-YF3JB30</b> [Weight: 441 g]
	<b>ZP3EU-YF3JB50</b> [Weight: 466 g]

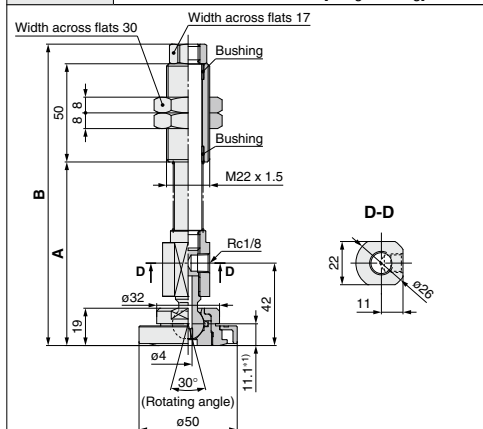

### Dimensions

Part no.	A	B
<b>ZP3EU-YF3JB10</b>	93.5	153.5
<b>ZP3EU-YF3JB30</b>	118.5	178.5
<b>ZP3EU-YF3JB50</b>	138.5	198.5

Applicable pad part no.
<b>ZP3E-63UM</b> <input type="checkbox"/>
<b>ZP3E-80UM</b> <input type="checkbox"/>
<b>ZP3E-63BM</b> <input type="checkbox"/>

Part no.	<b>ZP3EU-YF4JB10</b> [Weight: 430 g]
	<b>ZP3EU-YF4JB30</b> [Weight: 461 g]
	<b>ZP3EU-YF4JB50</b> [Weight: 486 g]

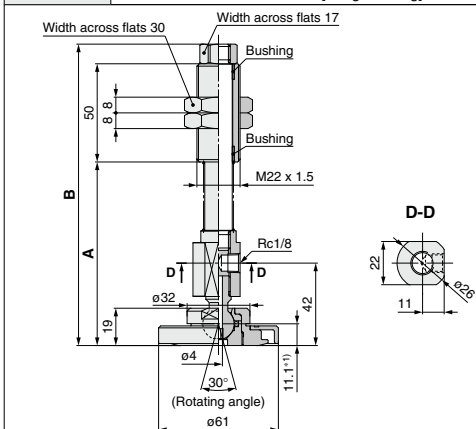

### Dimensions

Part no.	A	B
<b>ZP3EU-YF4JB10</b>	93.5	153.5
<b>ZP3EU-YF4JB30</b>	118.5	178.5
<b>ZP3EU-YF4JB50</b>	138.5	198.5

Applicable pad part no.
<b>ZP3E-100UM</b> <input type="checkbox"/>
<b>ZP3E-80BM</b> <input type="checkbox"/>

Part no.	<b>ZP3EU-YF5JB10</b> [Weight: 473 g]
	<b>ZP3EU-YF5JB30</b> [Weight: 504 g]
	<b>ZP3EU-YF5JB50</b> [Weight: 529 g]

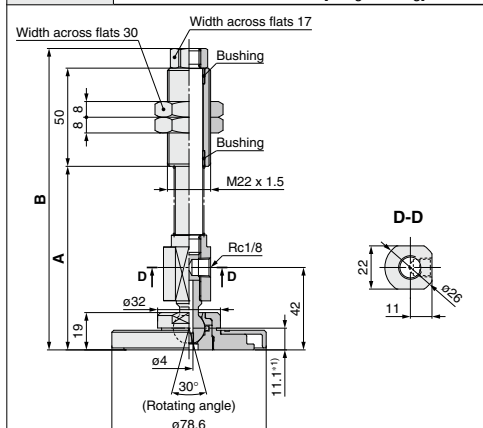

### Dimensions

Part no.	A	B
<b>ZP3EU-YF5JB10</b>	93.5	153.5
<b>ZP3EU-YF5JB30</b>	118.5	178.5
<b>ZP3EU-YF5JB50</b>	138.5	198.5

Applicable pad part no.
<b>ZP3E-125UM</b> <input type="checkbox"/>
<b>ZP3E-100BM</b> <input type="checkbox"/>

Part no.	<b>ZP3EU-YF6JB10</b> [Weight: 520 g]
	<b>ZP3EU-YF6JB30</b> [Weight: 551 g]
	<b>ZP3EU-YF6JB50</b> [Weight: 576 g]

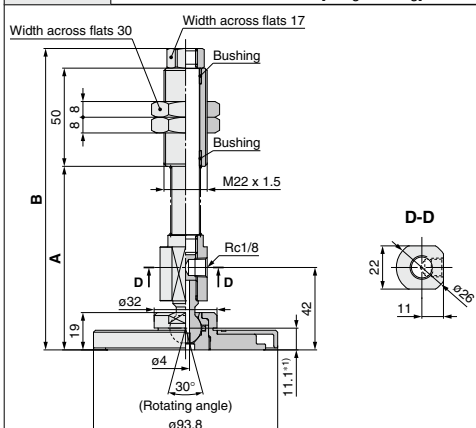

### Dimensions

Part no.	A	B
<b>ZP3EU-YF6JB10</b>	93.5	153.5
<b>ZP3EU-YF6JB30</b>	118.5	178.5
<b>ZP3EU-YF6JB50</b>	138.5	198.5

Applicable pad part no.
<b>ZP3E-125BM</b> <input type="checkbox"/>

\*1) Center of the rotating angle