

Low Profile Air Gripper

Series *MHF2*

RoHS



Low profile air gripper with space-saving design

- MHZ
- MHF**
- MHL
- MHR
- MHK
- MHS
- MHC
- MHT-Z
- MHY
- MHW
- X□
- MRHQ
- MA
- D-□

Low Profile Air Gripper

Series MHF2

Height is approximately 1/3 the size of an equivalent Series MHZ2.

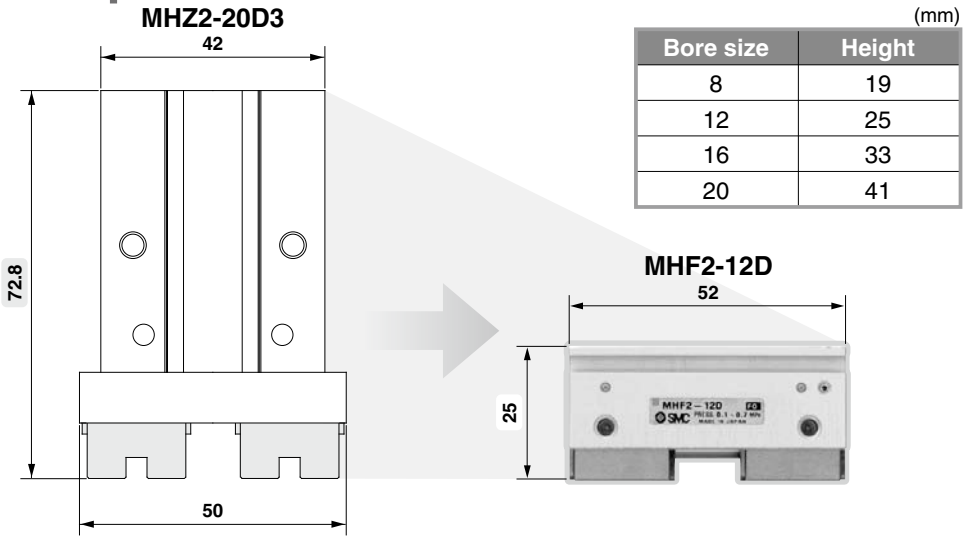

- The low profile design saves space and reduces bending moments.
- Improved accuracy with smooth operation

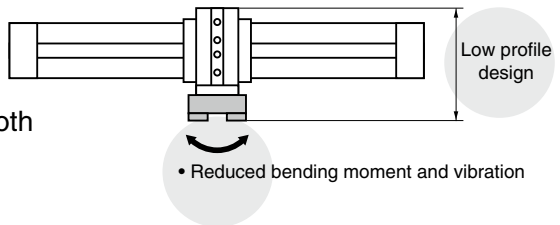

Stroke selection is available.

3 standard stroke lengths are available for each bore size.

Stroke can be selected to suit the workpiece.

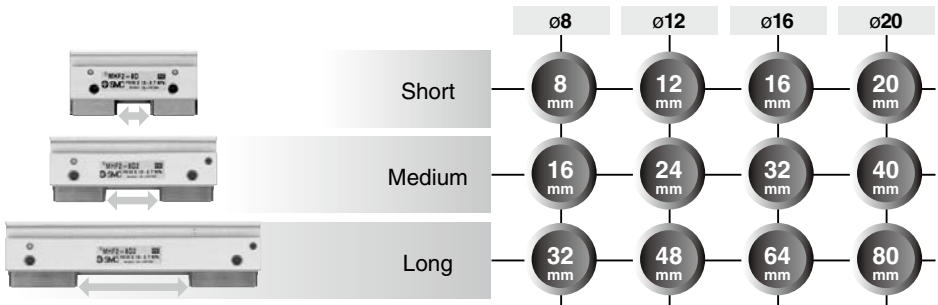

Improved mounting repeatability

With positioning pin holes

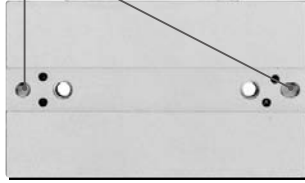

Auto switches can be mounted on both sides.

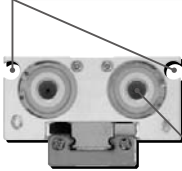

Piping is available from 2 directions

Piping port position can be specified using a part number.

Linear guide provides:

High precision and high rigidity with martensitic stainless steel

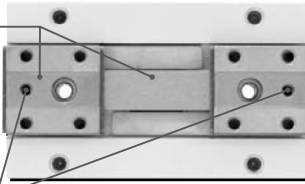

Easy positioning for mounting attachments

With positioning pin holes

Centralized wiring and piping are possible.

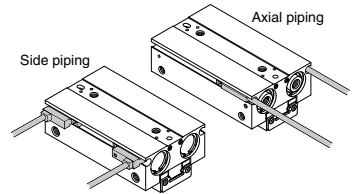

High degree of mounting flexibility

As no brackets are required, mounting height can be minimized.

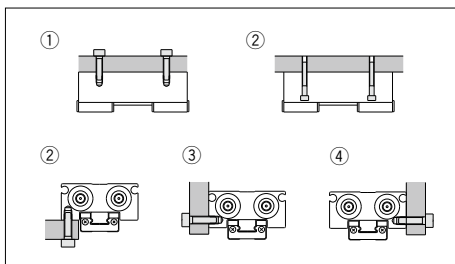
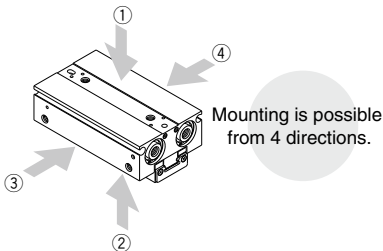

Strong gripping force

Double piston construction achieves compact design with strong gripping force.

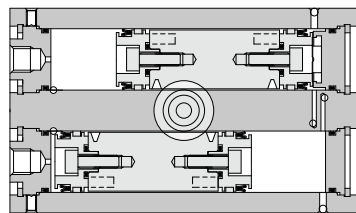

Model	Bore size	Gripping force (N)
MHF2-8D□	8	19
MHZ2-10D□	10	11
MHF2-12D□	12	48
MHZ2-20D□	20	42
MHF2-16D□	16	90
MHZ2-25D□	25	65
MHF2-20D□	20	141
MHZ2-32D□	32	158

MHZ

MHF

MHL

MHR

MHK

MHS

MHC

MHT-Z

MHY

MHW

-X□

MRHQ

MA

D-□

Series MHF2

Model Selection

Model Selection

Selection Procedure

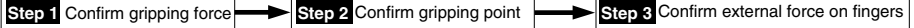

Step 1 Confirmation of Gripping Force



Example Workpiece mass: 0.15 kg

Gripping method: External gripping

Length of gripping point: 30 mm

Operating pressure: 0.4 MPa

Model selection criteria with respect to workpiece mass

- Although differences will exist depending on factors such as shape and the coefficient of friction between attachments and workpieces, select a model which will provide a gripping force 10 to 20 times the weight of the workpiece.
- (Note1) Refer to the model selection illustration for more information.
- Furthermore, in cases with high acceleration or impact, etc., it is necessary to allow an even greater margin of safety.

Example

When it is desired to set the gripping force at 20 times or more the workpiece weight. Required gripping force = 0.15 kg x 20 x 9.8 m/s² = Approx. 29.4 N or more

MHF2-12D

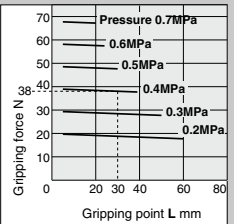

Selecting the MHF2-12D

- The gripping force is obtained from the intersection point of the gripping point distance L = 30 mm and a pressure of 0.4 MPa. Gripping force N = 38 N
- A gripping force of 38 N satisfies the required gripping force of 29.4 N. Therefore, the selection of MHF2-12D is appropriate.

Model Selection Illustration

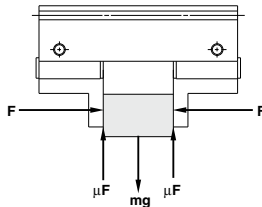

Gripping force at least 10 to 20 times the workpiece weight

The "10 to 20 times or more of the workpiece weight" recommended by SMC is calculated with the safety margin of a = 4, which allows for impacts that occur during normal transportation, etc.

When $\mu = 0.2$	When $\mu = 0.1$
$F = \frac{mg}{2 \times 0.2} \times 4$ $= 10 \times mg$	$F = \frac{mg}{2 \times 0.1} \times 4$ $= 20 \times mg$

10 x workpiece weight

20 x workpiece weight

When gripping a workpiece as in the figure to the left and with the following definitions,

F: Gripping force (N)

μ : Coefficient of friction between attachments and workpiece

m: Workpiece mass (kg)

g: Gravitational acceleration (= 9.8 m/s²)

mg: Workpiece weight (N)

the conditions under which the workpiece will not drop are

$$2 \times \mu F > mg$$

Number of fingers

and therefore,

$$F > \frac{mg}{2 \times \mu}$$

With "a" as the safety margin, F is determined as follows:

$$F = \frac{mg}{2 \times \mu} \times a$$

(Note) · Even in cases where the coefficient of friction is greater than $\mu = 0.2$, for safety reasons, SMC recommends selecting a gripping force which is at least 10 to 20 times the workpiece weight.

· It is necessary to allow a greater safety margin for high accelerations and strong impacts, etc.

Step 1 Effective Gripping Force: Series MHF2

- Expressing the effective gripping force
The effective gripping force shown in the graphs below is expressed as F, which is the thrust of one finger when both fingers and attachments are in full contact with the workpiece as shown in the figure below.

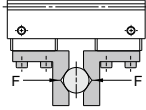

External Gripping

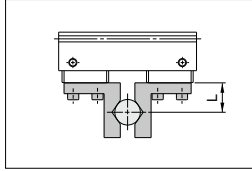

Internal Gripping

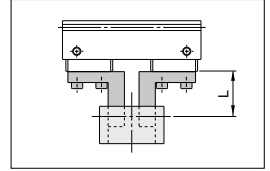

MHF2-8D

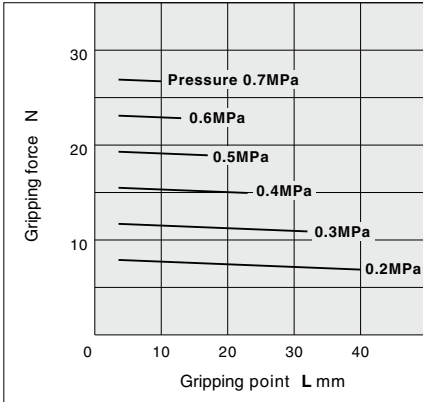

MHF2-12D

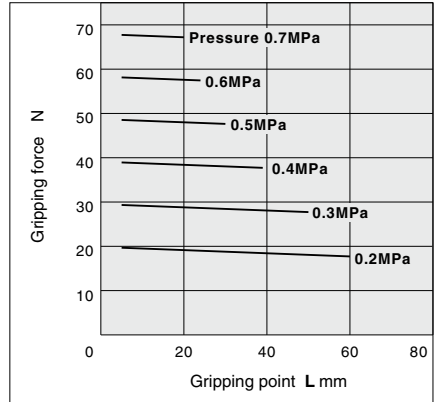

MHF2-16D

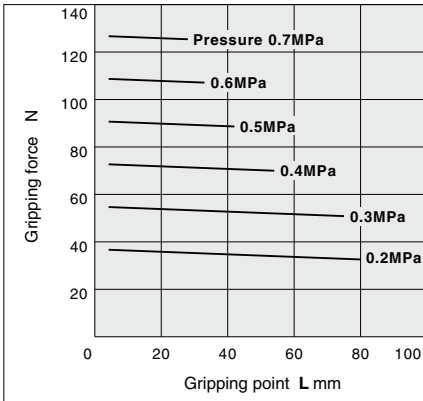

MHF2-20D

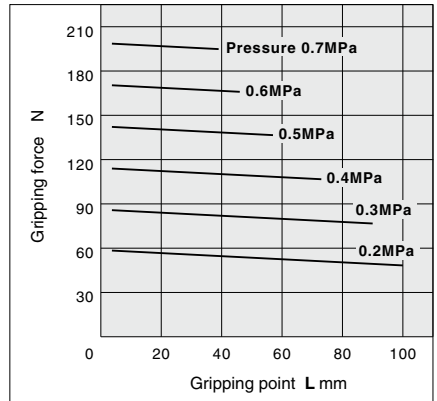

MHZ

MHF

MHL

MHR

MHK

MHS

MHC

MHT-Z

MHY

MHW

-X

MRHQ

MA

D

Model Selection

Step 2 Effective Gripping Force: Series MHF2

External Gripping

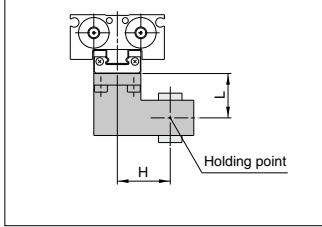

Internal Gripping

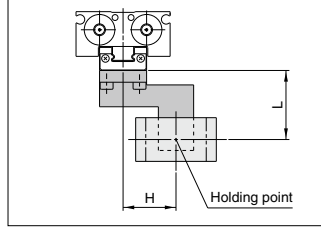

- The air gripper should be operated so that the amount of overhang "H" will stay within the range given in the graphs below.
- If the workpiece gripping point goes beyond the range limits, this will have an adverse effect on the life of the air gripper.

MHF2-8D □

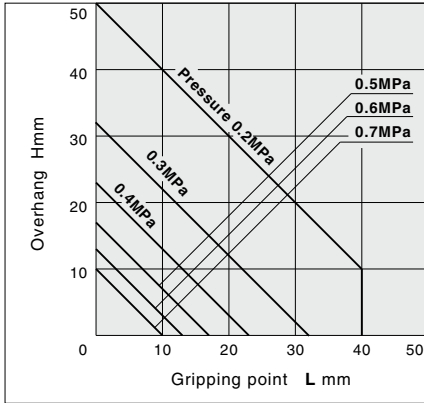

MHF2-12D □

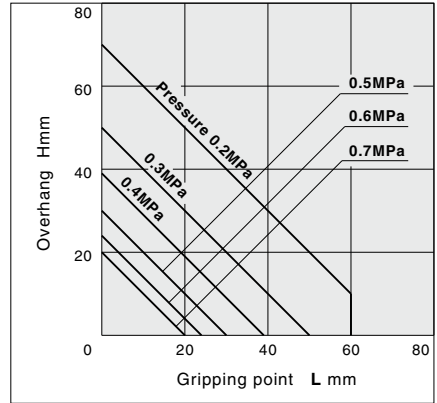

MHF2-16D □

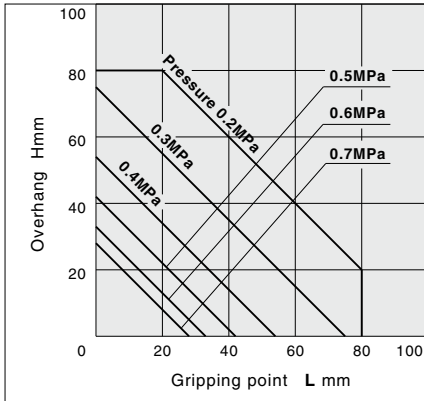

MHF2-20D □

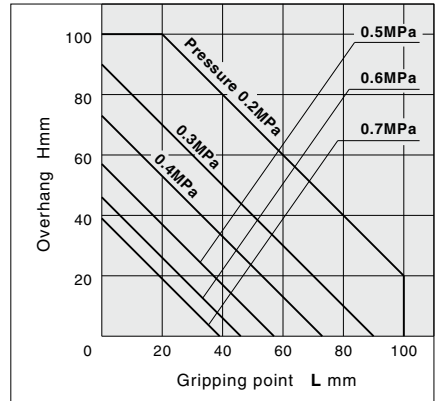

Step 3 Confirmation of External Force on Fingers: Series MHF2

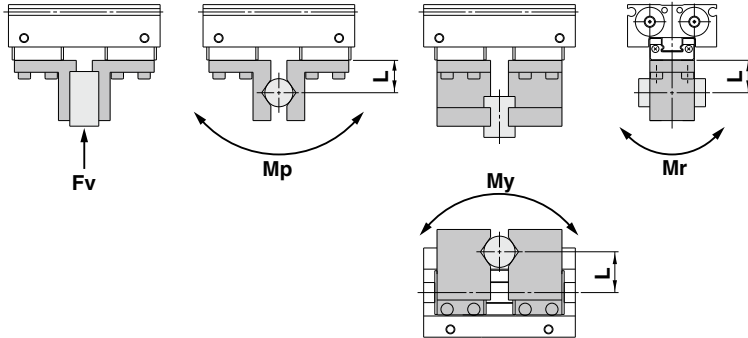

L: Distance to the point at which the load is applied (mm)

Model	Allowable vertical load Fv (N)	Maximum allowable moment		
		Pitch moment Mp (N-m)	Yaw moment My (N-m)	Roll moment Mr (N-m)
MHF2-8D□	58	0.26	0.26	0.53
MHF2-12D□	98	0.68	0.68	1.4
MHF2-16D□	176	1.4	1.4	2.8
MHF2-20D□	294	2	2	4

Note) The load and moment values in the table indicate static values.

Calculation of allowable external force (when moment load is applied)	Calculation example
$\text{Allowable load } F \text{ (N)} = \frac{M \text{ (Maximum allowable moment) (N-m)}}{L \times 10^{-3} \text{ }^{\ast}}$ <p>([*] Unit converted invariable number)</p>	<p>When a load $f = 10 \text{ N}$ is operating, which applies pitch moment to point $L = 30 \text{ mm}$ from the end of the MHF2-12D finger.</p> $\text{Allowable load } F = \frac{0.68}{30 \times 10^{-3}} = 22.7 \text{ (N)}$ <p>Load $f = 10 \text{ (N)} < 22.7 \text{ (N)}$ Therefore, it can be used.</p>

- MHZ
- MHF**
- MHL
- MHR
- MHK
- MHS
- MHC
- MHT-Z
- MHY
- MHW
- X□
- MRHQ
- MA
- D-□

Low Profile Air Gripper Series *MHF2*



How to Order

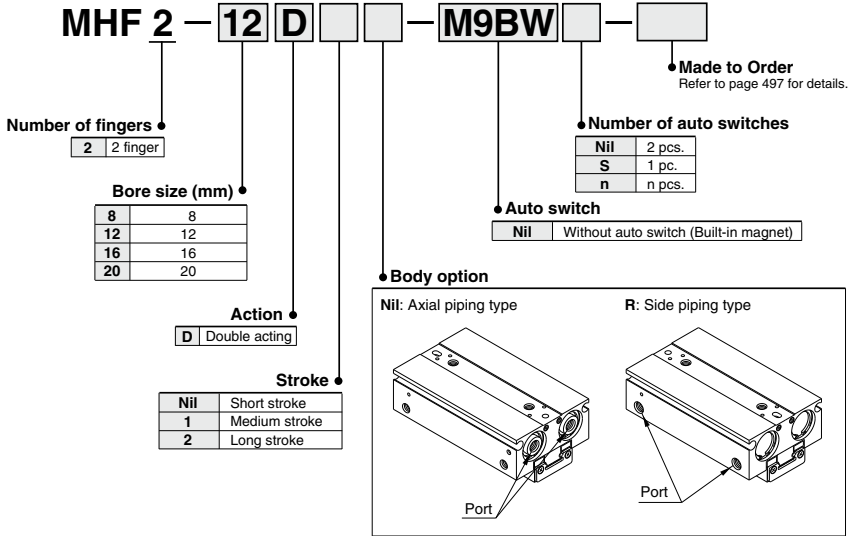

Applicable Auto Switches

Refer to pages 807 to 856 for further information on auto switches.

Type	Special function	Electrical entry	Indicator light	Wiring (Output)	Load voltage		Auto switch model		Lead wire length (m)*			Pre-wired connector	Applicable load	
					DC	AC	Electrical entry direction		0.5 (Nil)	1 (M)	3 (L)			5 (Z)
							Perpendicular	In-line						
Solid state auto switch	—	Grommet	Yes	3-wire (NPN)	5 V, 12 V	—	M9NV	M9N	●	●	○	○	IC circuit	
				3-wire (PNP)			M9PV	M9P	●	●	○	○		
				2-wire	M9BV		M9B	●	●	○	○	—		
				3-wire (NPN)	M9NVV		M9NV	●	●	○	○	IC circuit		
				3-wire (PNP)	M9PVV		M9PV	●	●	○	○	IC circuit		
				2-wire	M9BVV		M9BV	●	●	○	○	—		
	Water resistant (2-color indicator)	Grommet	Yes	No	3-wire (NPN)	5 V, 12 V	M9NAV**	M9NA**	○	○	●	○	○	IC circuit
					3-wire (PNP)		M9PAV**	M9PA**	○	○	●	○	IC circuit	
					2-wire	M9BAV**	M9BA**	○	○	●	○	—		

** Water resistant type auto switches can be mounted on the above models, but in such case SMC cannot guarantee water resistance.

* Lead wire length symbols: 0.5 m Nil (Example) M9NW * Auto switches marked with "O" are made to order specification.

1 m M (Example) M9NWM

3 m L (Example) M9NWL

5 m Z (Example) M9NWX

Note) When using the 2-color indicator type, please make the setting so that the indicator is lit in red to ensure the detection at the proper position of the air gripper.

Specifications

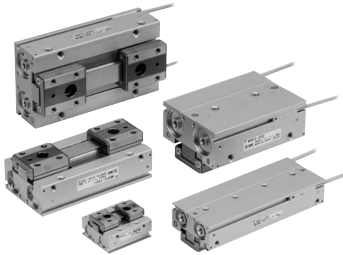

Fluid		Air
Operating pressure		ø8: 0.15 to 0.7 MPa ø12 to 20: 0.1 to 0.7 MPa
Ambient and fluid temperature		-10 to 60°C (with no condensation)
Repeatability		±0.05 mm ^{Note 1)}
Maximum operating frequency	Short stroke	120 c.p.m.
	Medium stroke	120 c.p.m.
	Long stroke	60 c.p.m.
Lubrication		Not required
Action		Double acting
Auto switch (Option) ^{Note 2)}		Solid state auto switch (3-wire, 2-wire)

Note 1) This is the value when no offset load is applied to the finger.

When an offset load is applied to the finger, the maximum value is ±0.15 mm due to the influence of backlash of the rack and pinion.

Note 2) Refer to pages 807 to 856 for further information on auto switches.

Symbol

Double acting:
Internal grip

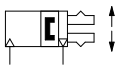

Double acting:
External grip

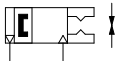

Made to Order

Refer to pages 727 to 759 for details.

Symbol	Specifications/Description
-X4	Heat resistance (100°C)
-X5	Fluororubber seal
-X50	Without magnet
-X53	EPDM seal/Fluorine grease
-X63	Fluorine grease
-X79	Grease for food processing machines, Fluorine grease
-X79A	Grease for food processing machines
-X81A	Anti-corrosive treatment of finger
-X81B	Anti-corrosive treatment of finger, guide and joint
-X83	With an adjustable opening/closing finger positioning

Moisture Control Tube Series IDK



When operating an actuator with a small diameter and a short stroke at a high frequency, the dew condensation (water droplet) may occur inside the piping depending on the conditions.

Simply connecting the moisture control tube to the actuator will prevent dew condensation from occurring. For details, refer to [Series IDK in the WEB catalog](#).

Model

Action	Model	Cylinder bore (mm)	Gripping force ^{Note 1)}		Opening / closing stroke (Both sides) mm	Weight ^{Note 2)}		Unobstructed capacity (cm ³)	
			Effective gripping force per finger N			Finger open side	Finger close side		
Double acting	MHF2-8D	8	19		8	65	0.7	0.6	
	MHF2-8D1				16	85	1.1	1.0	
	MHF2-8D2				32	120	2.0	1.9	
	MHF2-12D	12	48		12	155	1.9	1.6	
	MHF2-12D1				24	190	3.3	3.0	
	MHF2-12D2				48	275	6.1	5.8	
	MHF2-16D	16	90		16	350	4.9	4.1	
	MHF2-16D1				32	445	8.2	7.4	
	MHF2-16D2				64	650	14.9	14.0	
	MHF2-20D	20	141		20	645	8.7	7.3	
	MHF2-20D1				40	850	15.1	13.7	
	MHF2-20D2				80	1,225	28.0	26.6	

Note 1) At the pressure of 0.5 MPa, when gripping point L is 20 mm.

Note 2) Excluding the auto switch weight.

MHZ

MHF

MHL

MHR

MHK

MHS

MHC

MHT

-Z

MHY

MHW

-X□

MRHQ

MA

D-□

Series MHF2

Construction

MHF2-8D, MHF2-8D1

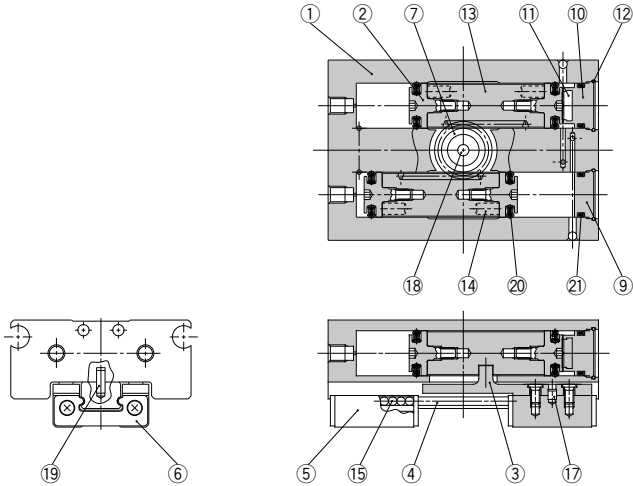

MHF2-8D2

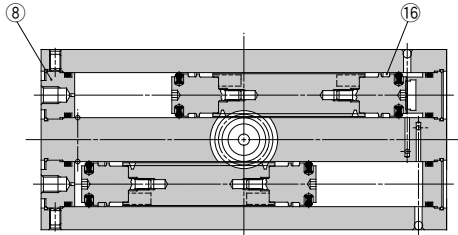

Component Parts

No.	Description	Material	Note
1	Body	Aluminum alloy	Hard anodized
2	Piston	Stainless steel	
3	Joint	Stainless steel	Heat treatment
4	Guide rail	Stainless steel	Heat treatment
5	Finger	Stainless steel	Heat treatment
6	Roller stopper	Stainless steel	
7	Pinion	Carbon steel	Nitriding
8	Cap A	Aluminum alloy	Clear anodized
9	Cap B	Aluminum alloy	Clear anodized
10	Cap C	Aluminum alloy	Clear anodized

Component Parts

No.	Description	Material	Note
11	Head damper	Urethane rubber	
12	Clip	Stainless steel wire	
13	Rack	Stainless steel	Nitriding
14	Magnet	—	Nickel plated
15	Steel balls	High carbon chromium bearing steel	
16	Wear ring	Synthetic resin	
17	Roller	High carbon chromium bearing steel	
18	Needle roller	High carbon chromium bearing steel	
19	Parallel pin	Stainless steel	
20	Piston seal	NBR	
21	Gasket	NBR	

Replacement Parts

Description	Kit no.			Contents
	MHF2-8D	MHF2-8D1	MHF2-8D2	
Seal kit	MHF8-PS	MHF8-PS	MHF8-PS-2	12, 20, 21
Finger assembly	MHF-A0802	MHF-A0802-1	MHF-A0802-2	3, 4, 5, 6, 15, 17, 19 Mounting screw

Replacement part/Grease pack part no.:

Guide unit: GR-S-010 (10 g)
Cylinder unit: GR-L-005 (5 g)

Bolts for Body Through-hole Mounting

Part no.	Number of pieces	
	MHF2-8D	MHF2-8D1
MHF-B08	MHF2-8D	2 pieces/unit
	MHF2-8D1	2 pieces/unit
	MHF2-8D2	4 pieces/unit

* The bolts for body through-hole mounting are attached to the product. They are also provided at an order of 1 piece or more with the above part numbers.

Construction

MHF2-12D□ to 20D□

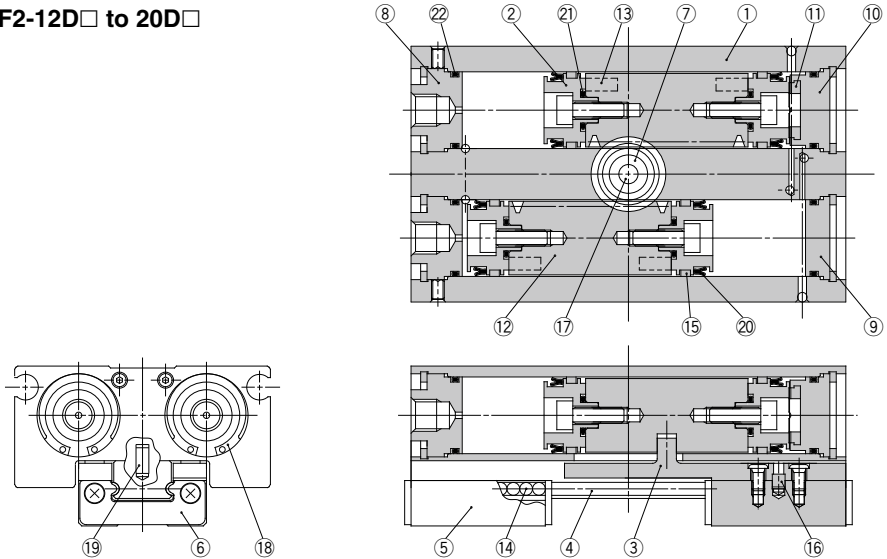

Component Parts

No.	Description	Material	Note
1	Body	Aluminum alloy	Hard anodized
2	Piston	Aluminum alloy	Clear anodized
3	Joint	Stainless steel	Heat treatment
4	Guide rail	Stainless steel	Heat treatment
5	Finger	Stainless steel	Heat treatment
6	Roller stopper	Stainless steel	
7	Pinion	Carbon steel	Nitriding
8	Cap A	Aluminum alloy	Clear anodized
9	Cap B	Aluminum alloy	Clear anodized
10	Cap C	Aluminum alloy	Clear anodized
11	Head damper	Urethane rubber	
12	Rack	Stainless steel	Nitriding

No.	Description	Material	Note
13	Magnet	—	Nickel plated
14	Steel balls	High carbon chromium bearing steel	
15	Wear ring	Synthetic resin	
16	Roller	High carbon chromium bearing steel	
17	Needle roller	High carbon chromium bearing steel	
18	Retaining ring	Carbon steel	Phosphate coated
19	Parallel pin	Stainless steel	
20	Piston seal	NBR	
21	Gasket	NBR	
22	Gasket	NBR	

Replacement Parts

Description	Kit no.			Contents
	MHF2-12D	MHF2-12D1	MHF2-12D2	
Seal kit	MHF12-PS	MHF12-PS	MHF12-PS	20, 21, 22
Finger assembly	MHF-A1202	MHF-A1202-1	MHF-A1202-2	3, 4, 5, 6, 14, 16, 19 Mounting screw
Description	Kit no.			Contents
	MHF2-16D	MHF2-16D1	MHF2-16D2	
Seal kit	MHF16-PS	MHF16-PS	MHF16-PS	20, 21, 22
Finger assembly	MHF-A1602	MHF-A1602-1	MHF-A1602-2	3, 4, 5, 6, 14, 16, 19 Mounting screw
Description	Kit no.			Contents
	MHF2-20D	MHF2-20D1	MHF2-20D2	
Seal kit	MHF20-PS	MHF20-PS	MHF20-PS	20, 21, 22
Finger assembly	MHF-A2002	MHF-A2002-1	MHF-A2002-2	3, 4, 5, 6, 14, 16, 19 Mounting screw

Replacement part/Grease pack part no.:

MHF2-□□D, D1 (σ12, 16, 20)	GR-S-010 (10 g) (Guide unit)
MHF2-□□D2 (σ12)	GR-L-005 (5 g) (Cylinder unit)
MHF2-□□D2 (σ16, 20)	GR-S-010 (10 g) (Guide unit)
	GR-L-010 (10 g) (Cylinder unit)

Bolts for Body Through-hole Mounting

Part no.	Number of pieces	
MHF-B12	MHF2-12D	2 pieces/unit
	MHF2-12D1	2 pieces/unit
	MHF2-12D2	4 pieces/unit

* The bolts for body through-hole mounting are attached to the product. They are also provided at an order of 1 piece or more with the above part numbers.

* When mounting MHF2-16D□ or MHF2-20D□ with the body through-holes, use hexagon socket head screws available on the market.

MHZ

MHF

MHL

MHR

MHK

MHS

MHC

MHT-Z

MHY

MHW

-X□

MRHQ

MA

D-□

Series MHF2

Dimensions

MHF2-8D

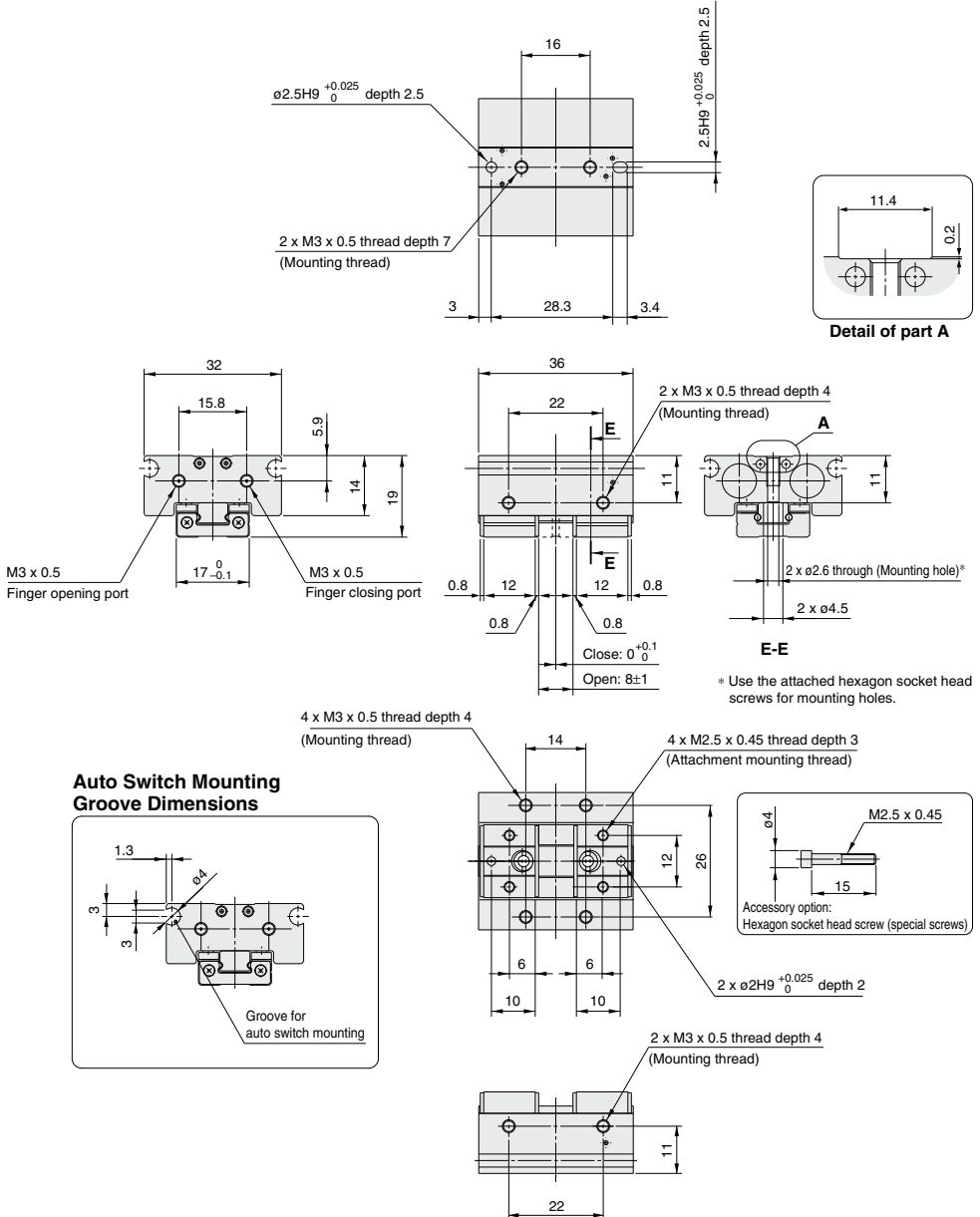

Dimensions

MHF2-8D1

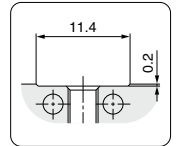
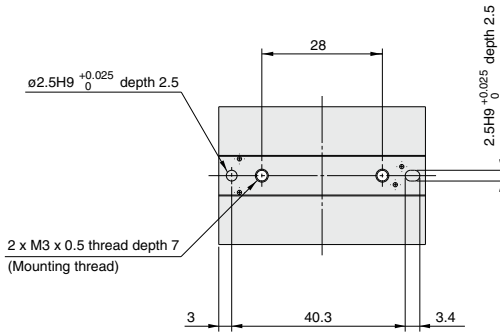

Detail of part A

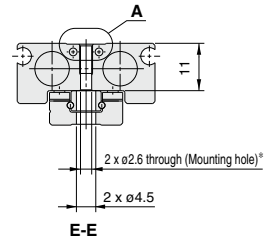
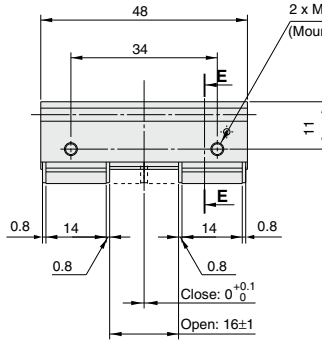
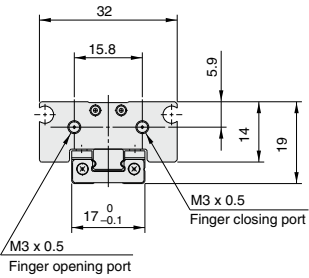

* Use the attached hexagon socket head screws for mounting holes.

Auto Switch Mounting Groove Dimensions

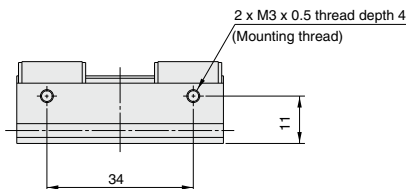
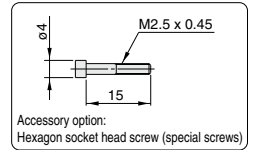
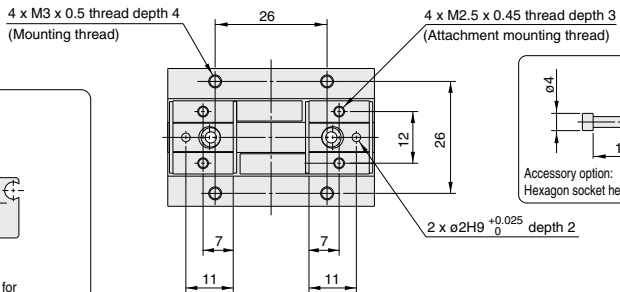
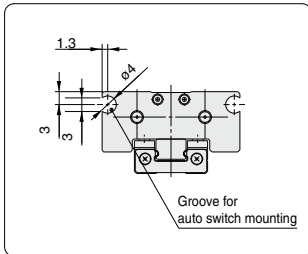

MHZ

MHF

MHL

MHR

MHK

MHS

MHC

MHT-Z

MHY

MHW

-X

MRHQ

MA

D-

Series MHF2

Dimensions

MHF2-8D2

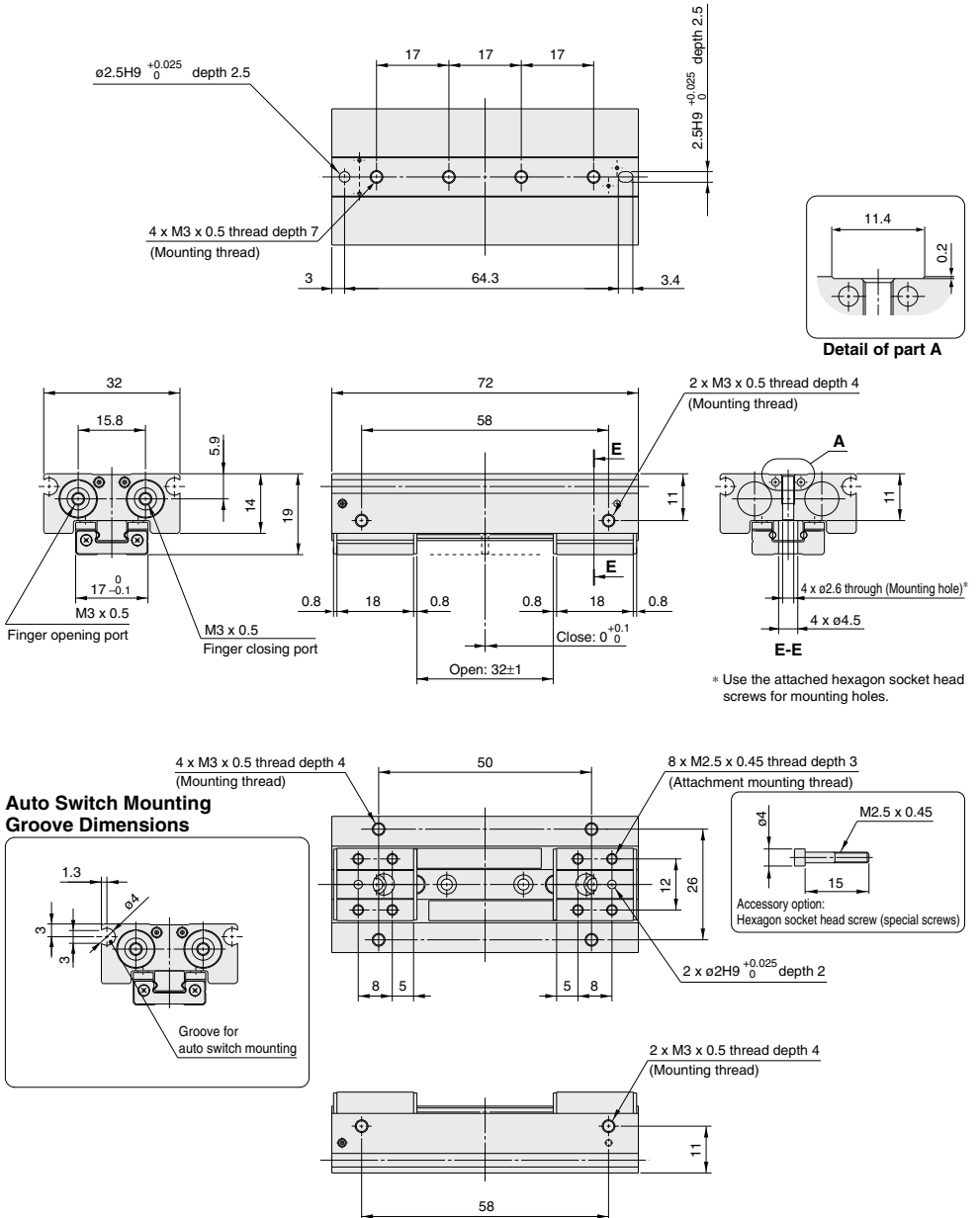

Dimensions

MHF2-12D

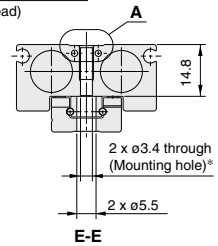
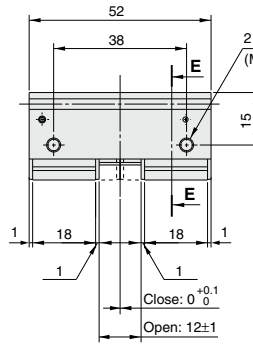
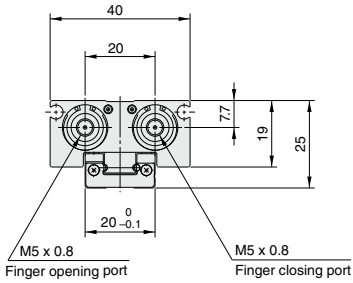
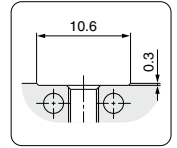
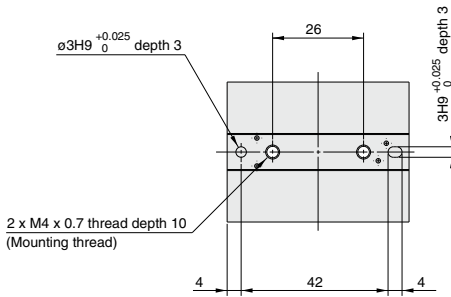

* Use the attached hexagon socket head screws for mounting holes.

Auto Switch Mounting Groove Dimensions

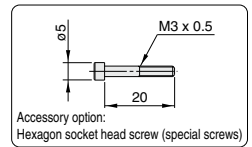
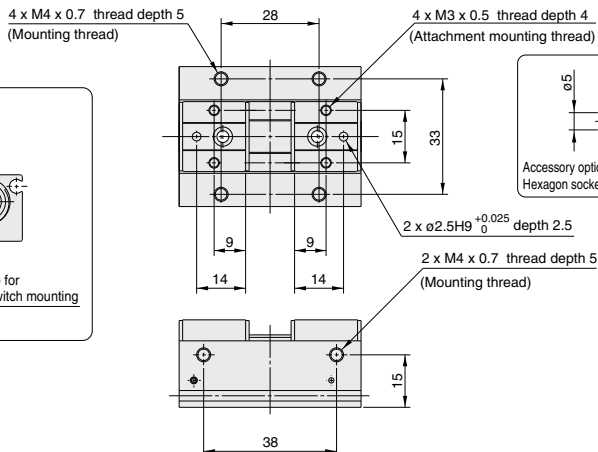
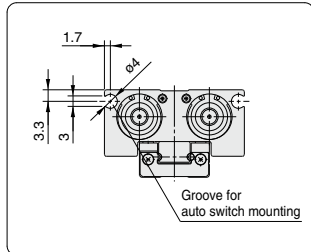

MHZ

MHF

MHL

MHR

MHK

MHS

MHC

MHT-Z

MHY

MHW

-X

MRHQ

MA

D-

Series MHF2

Dimensions

MHF2-12D1

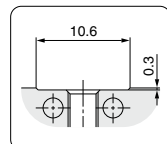
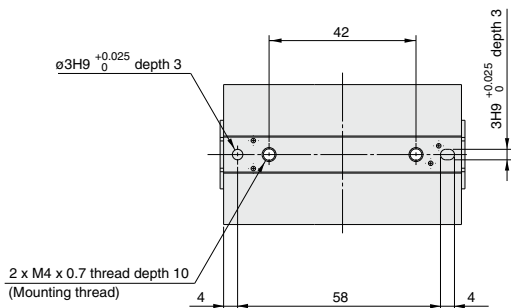

Detail of part A

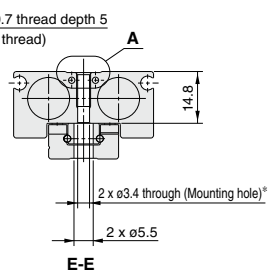
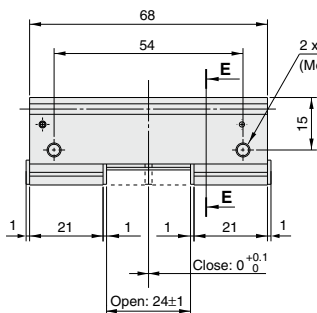
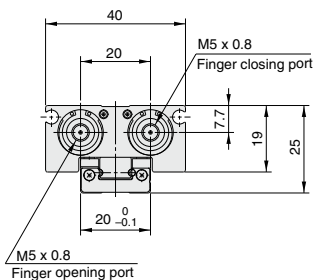

* Use the attached hexagon socket head screws for mounting holes.

Auto Switch Mounting Groove Dimensions

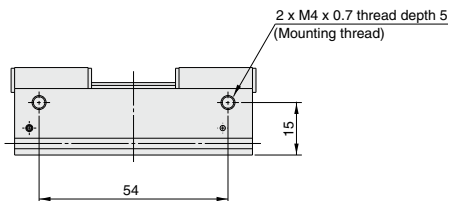
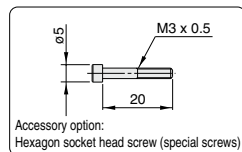
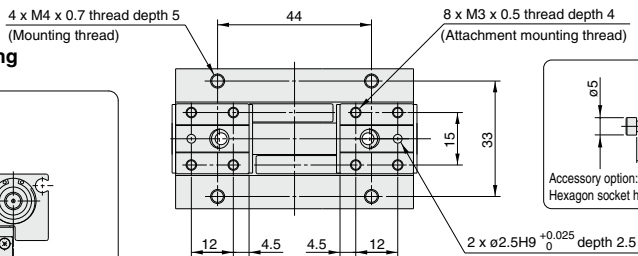
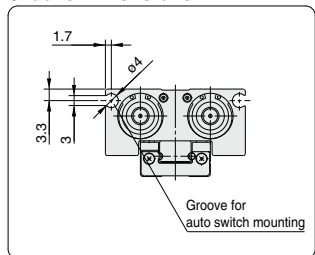

Dimensions

MHF2-12D2

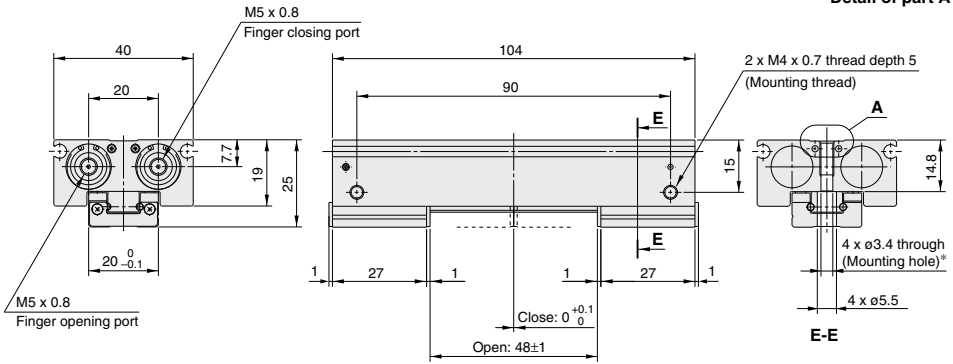
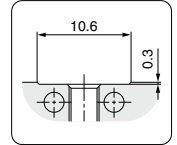
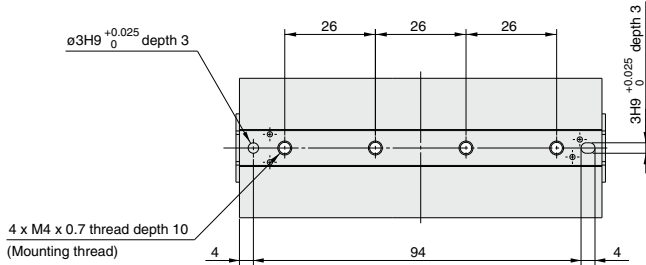

* Use the attached hexagon socket head screws for mounting holes.

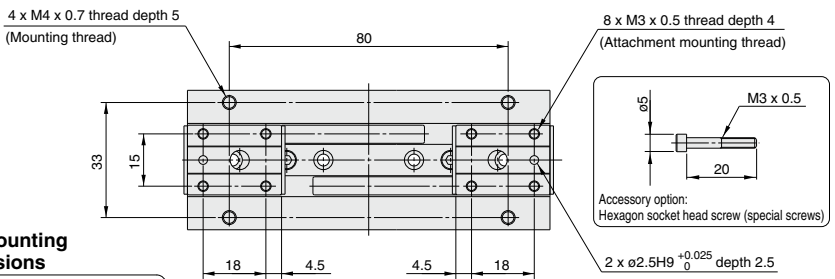

Auto Switch Mounting Groove Dimensions

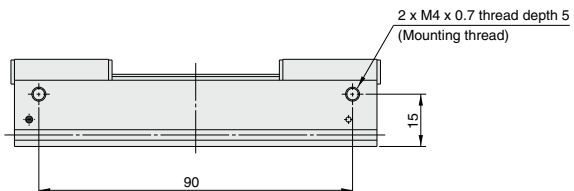
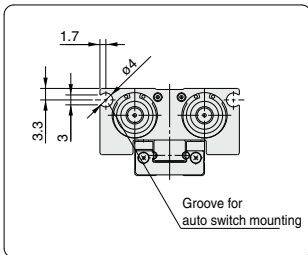

MHZ

MHF

MHL

MHR

MHK

MHS

MHC

MHT

-Z

MHY

MHW

-X

MRHQ

MA

D-

Series MHF2

Dimensions

MHF2-16D

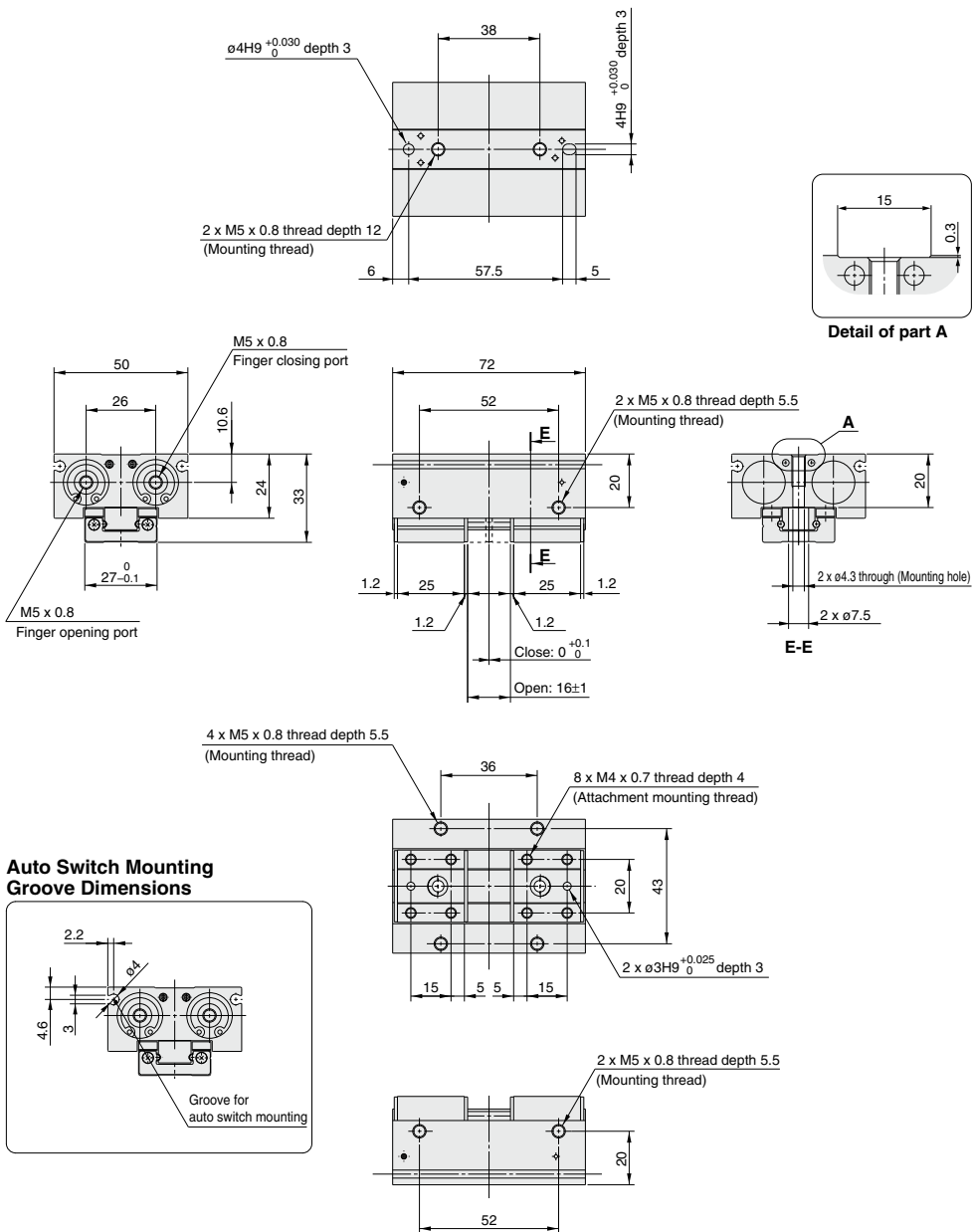

Dimensions

MHF2-16D1

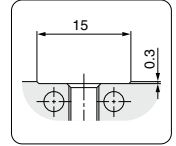
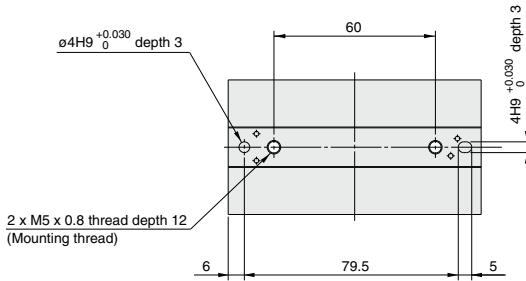

Detail of part A

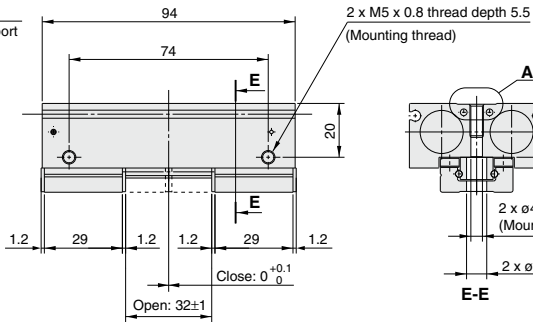
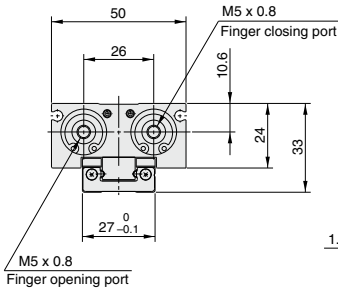

Auto Switch Mounting Groove Dimensions

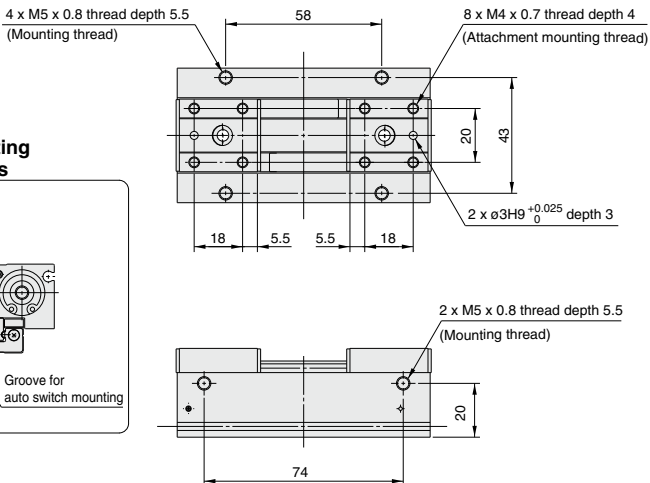
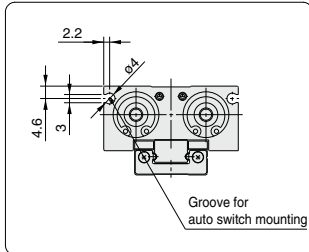

MHZ

MHF

MHL

MHR

MHK

MHS

MHC

MHT

-Z

MHY

MHW

-X

MRHQ

MA

D-

Series MHF2

Dimensions

MHF2-16D2

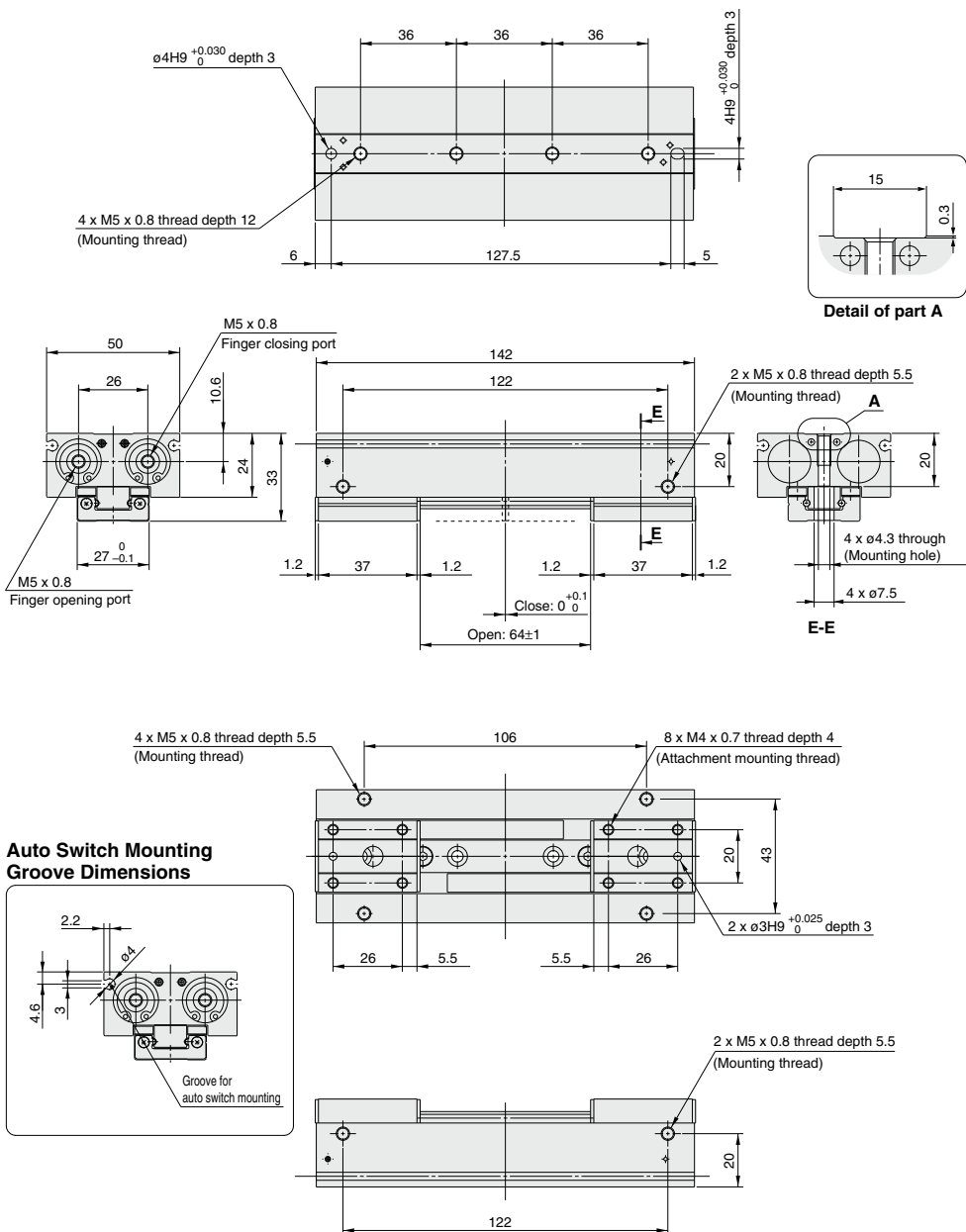

Dimensions

MHF2-20D

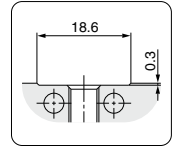
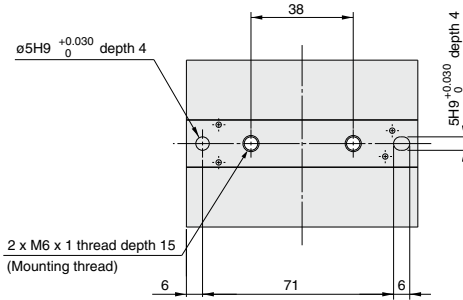

Detail of part A

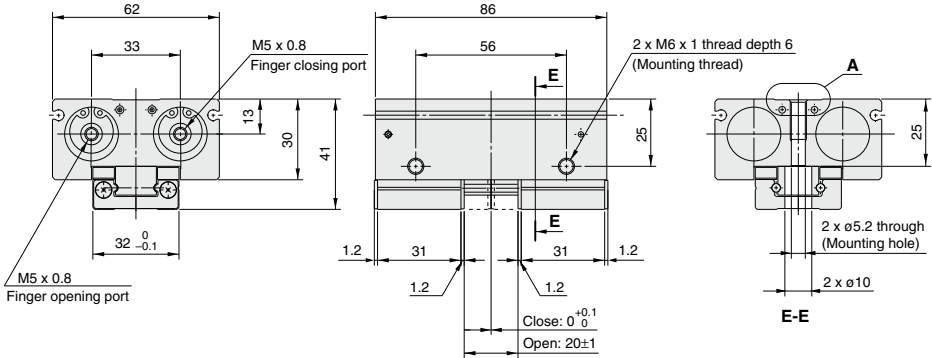

Auto Switch Mounting Groove Dimensions

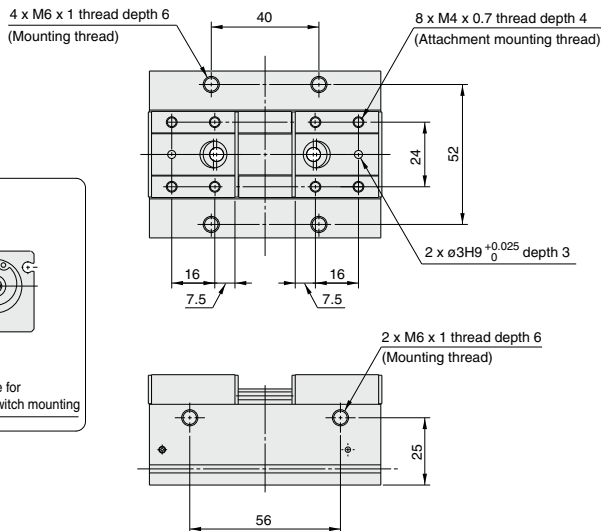
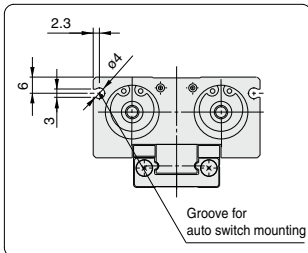

MHZ

MHF

MHL

MHR

MHK

MHS

MHC

MHT

-Z

MHY

MHW

-X

MRHQ

MA

D-

Series MHF2

Dimensions

MHF2-20D1

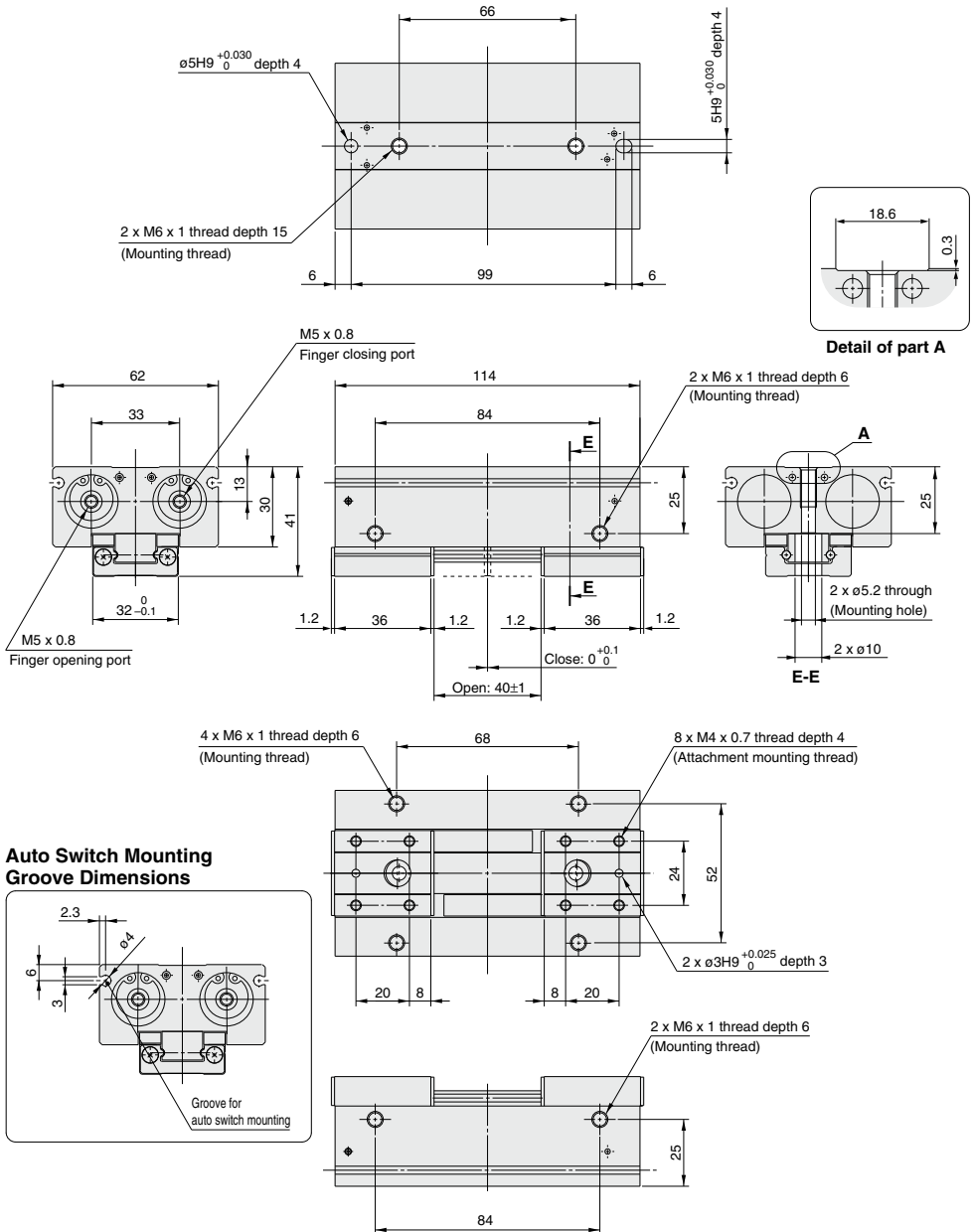

Dimensions

MHF2-20D2

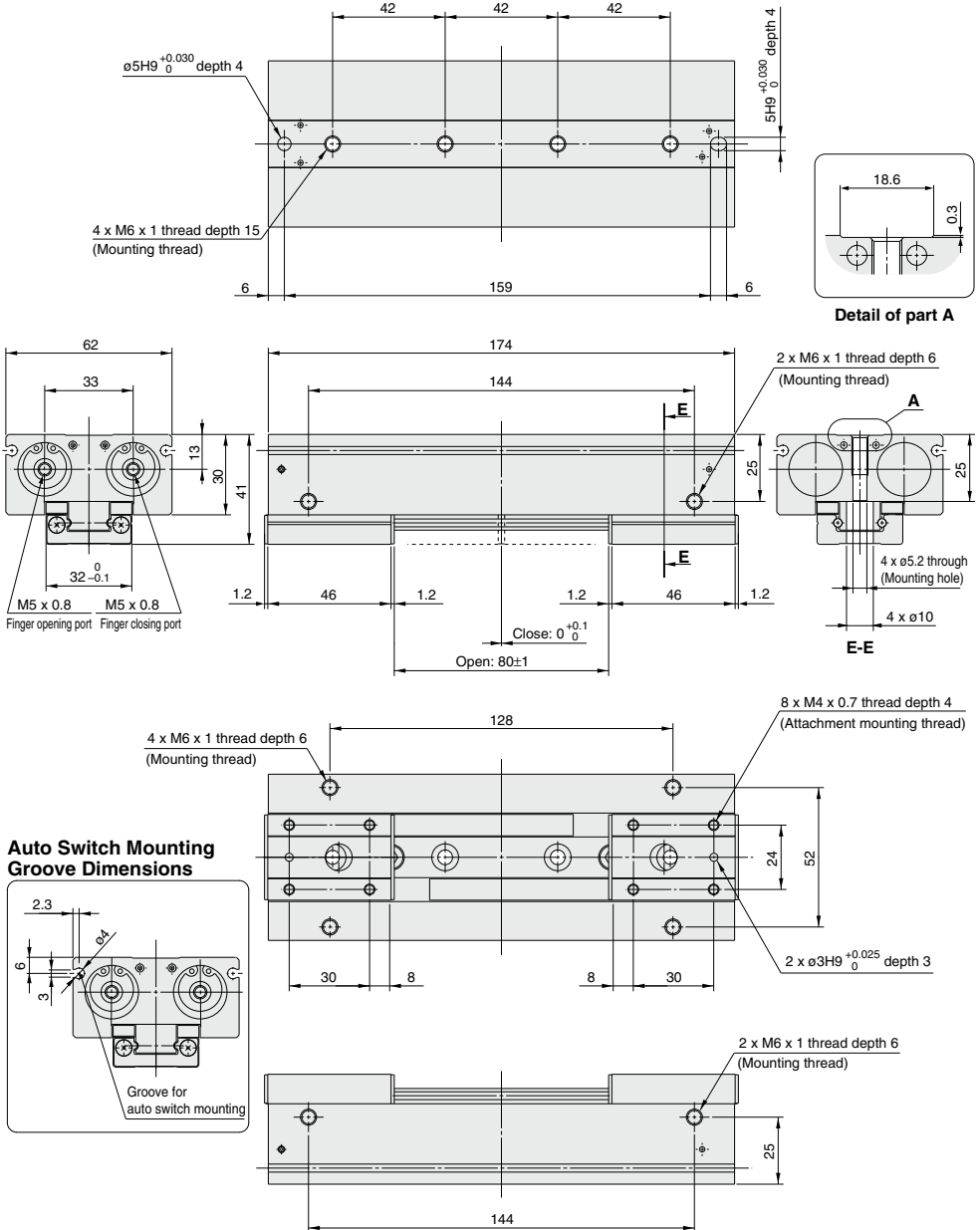

- MHZ
- MHF**
- MHL
- MHR
- MHK
- MHS
- MHC
- MHT-Z
- MHY
- MHW
- X
- MRHQ
- MA
- D-

Series MHF2

Body Option: Side Piping Type

MHF2-8DR
MHF2-8D1R

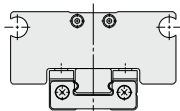

Port side of axial piping type

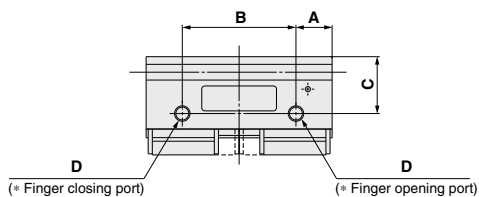

Body Option Dimension (mm)

Model	A	B	C	D
MHF2-8DR	5.5	25	11	M3 x 0.5
MHF2-8D1R		37		

MHF2-8D2R
MHF2-12D□R
MHF2-16D□R
MHF2-20D□R

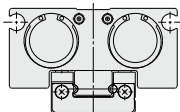

Port side of axial piping type

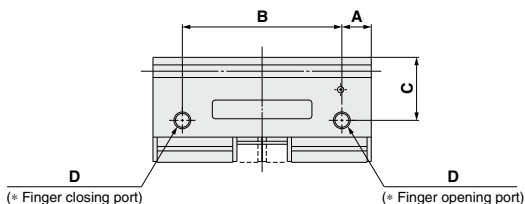

Body Option Dimension (mm)







Model	A	B	C	D
MHF2-8D2R	5.5	61	11	M3 x 0.5
MHF2-12DR	7	38	14.8	M5 x 0.8
MHF2-12D1R		54		
MHF2-12D2R		90		
MHF2-16DR	9	54	19	M5 x 0.8
MHF2-16D1R		76		
MHF2-16D2R		124		
MHF2-20DR	10	66	23	M5 x 0.8
MHF2-20D1R		94		
MHF2-20D2R		154		

* For dimensions not given above, please refer to the table of dimensions on pages 500 to 511.

Series MHF2 Auto Switch Installation Examples and Mounting Positions

Various auto switch applications are possible through different combinations of auto switch quantities and detecting positions.

1) Detection when Gripping Exterior of Workpiece

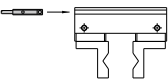
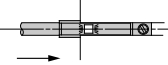
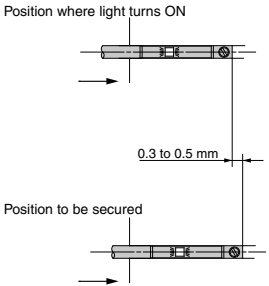
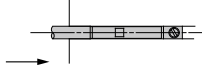
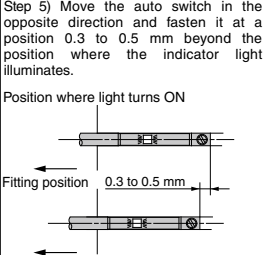
Detection example		1. Confirmation of fingers in reset position	2. Confirmation of workpiece held	3. Confirmation of workpiece released
Position to be detected		Position of fingers fully opened 	Position when gripping workpiece 	Position of fingers fully closed 
Operation of auto switch		Auto switch turned on when fingers return. (Light ON)	Auto switch turned on when gripping a workpiece. (Light ON)	When a workpiece is not held (Abnormal operation): Auto switch to turn ON (Light ON)
Detection combinations	One auto switch = One position, any of ①, ② and ③ can be detected.	●	●	●
	Two auto switches = Two positions of ①, ② and ③ can be detected.	A	●	—
		B	—	●
	C	●	—	
How to determine auto switch installation position	Step 1) Fully open the fingers. 	Step 1) Position fingers for gripping a workpiece. 	Step 1) Fully close the fingers. 	
	At no pressure or low pressure, connect the auto switch to a power supply, and follow the directions.	Step 2) Insert the auto switch into the auto switch installation groove in the direction shown in the drawing. 		
	Step 3) Slide the auto switch in the direction of the arrow until the indicator light illuminates. 	Step 3) Slide the auto switch in the direction of the arrow until the light illuminates and fasten it at a position 0.3 to 0.5 mm in the direction of the arrow beyond the position where the indicator light illuminates. 		
	Step 4) Slide the auto switch further in the direction of the arrow until the indicator light goes out. 			
	Step 5) Move the auto switch in the opposite direction and fasten it at a position 0.3 to 0.5 mm beyond the position where the indicator light illuminates. Position where light turns ON 			













Note 1) It is recommended that gripping of a workpiece be performed close to the center of the finger stroke.

Note 2) When holding a workpiece close at the end of open/close stroke of fingers, detecting performance of the combinations listed in the above table may be limited, depending on the hysteresis of an auto switch, etc.

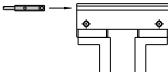
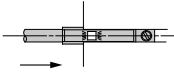
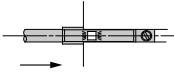
Series MFH2 Auto Switch Installation Examples and Mounting Positions

Various auto switch applications are possible through different combinations of auto switch quantities and detecting positions.

2) Detection when Gripping Interior of Workpiece

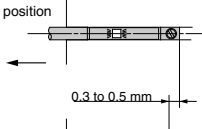
Detection example		1. Confirmation of fingers in reset position	2. Confirmation of workpiece held	3. Confirmation of workpiece released	
Position to be detected		Position of fingers fully closed 	Position when gripping workpiece 	Position of fingers fully opened 	
Operation of auto switch		Auto switch turned on when fingers return. (Light ON)	Auto switch turned on when gripping a workpiece. (Light ON)	When a workpiece is not held (Abnormal operation): Auto switch to turn ON (Light ON)	
Detection combinations	One auto switch = One position, any of ①, ② and ③ can be detected.	●	●	●	
	Two auto switches = Two positions of ①, ② and ③ can be detected.	A	●	—	
		B	—	●	
Pattern	C	●	—	●	
How to determine auto switch installation position		Step 1) Fully close the fingers. 	Step 1) Position fingers for gripping a workpiece. 	Step 1) Fully open the fingers. 	
At no pressure or low pressure, connect the auto switch to a power supply, and follow the directions.		Step 2) Insert the auto switch into the auto switch installation groove in the direction shown in the drawing. 			
		Step 3) Slide the auto switch in the direction of the arrow until the light illuminates and fasten it at a position 0.3 to 0.5 mm in the direction of the arrow beyond the position where the indicator light illuminates. 	Step 3) Slide the auto switch in the direction of the arrow until the indicator light illuminates. 		
		Indicator lighting position  Fitting position  0.3 to 0.5 mm	Step 4) Slide the auto switch further in the direction of the arrow until the indicator light goes out. 		
		Indicator lighting position  Fitting position  0.3 to 0.5 mm	Step 5) Move the auto switch in the opposite direction and fasten it at a position 0.3 to 0.5 mm beyond the position where the indicator light illuminates. 		

Note 1) It is recommended that gripping of a workpiece be performed close to the center of the finger stroke.

Note 2) When holding a workpiece close at the end of open/close stroke of fingers, detecting performance of the combinations listed in the above table may be limited, depending on the hysteresis of an auto switch, etc.

Auto Switch Hysteresis

Auto switches have hysteresis similar to micro switches. Use the table below as a guide when adjusting auto switch positions.

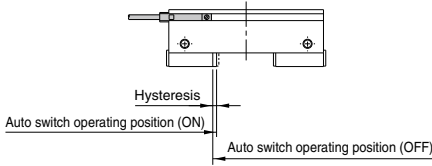

Hysteresis

	D-M9□(V) D-M9□W(V) D-M9□A(V)
MHF2-8D□	0.2
MHF2-12D□	0.3
MHF2-16D□	0.2
MHF2-20D□	0.5

Auto Switch Mounting

Insert the auto switch into the auto switch mounting groove in the air chuck in the direction shown below, and after setting the mounting position, tighten the attached switch mounting screw with a flat head watchmaker's screwdriver.

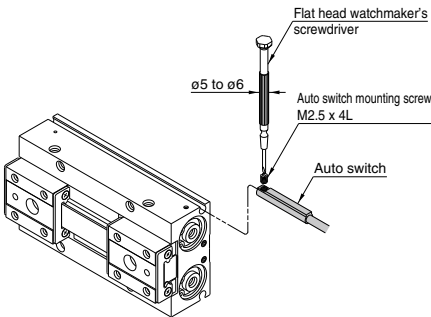

Note) Use a watchmaker's screwdriver with a grip diameter of 5 to 6 mm to tighten the auto switch mounting screw. The tightening torque should be about 0.05 to 0.15 N·m.

Caution

When using an auto switch on the mounting plate side, the switch will protrude from the end face as shown in the right figure. Please provide a run off space of 2 mm or more on the mounting plate.

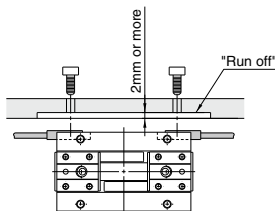

Protrusion of Auto Switch from Edge of Body

- The amount of auto switch protrusion from the body end surface is shown in the table below.
- Use this as a standard when mounting, etc.

Protrusion of Auto switch

Lead wire type Illustration Auto switch Finger position Model	In-line entry		Perpendicular entry		
	D-M9□ D-M9□W	D-M9□A	D-M9□V D-M9□VV	D-M9AV	
MHF2-8D	Open	6.5	8.5	4.5	6.5
	Close	6.5	8.5	4.5	6.5
MHF2-8D1	Open	6.5	8.5	4.5	6.5
	Close	6.5	8.5	4.5	6.5
MHF2-8D2	Open	0.5	2.5	—	—
	Close	0.5	2.5	—	—
MHF2-12D	Open	3	5	1	3
	Close	3	5	1	3
MHF2-12D1	Open	1	3	—	—
	Close	1	3	—	—
MHF2-12D2	Open	—	—	—	—
	Close	—	—	—	—
MHF2-16D	Open	—	—	—	—
	Close	—	—	—	—
MHF2-16D1	Open	—	—	—	—
	Close	—	—	—	—
MHF2-16D2	Open	—	—	—	—
	Close	—	—	—	—
MHF2-20D	Open	—	—	—	—
	Close	—	—	—	—
MHF2-20D1	Open	—	—	—	—
	Close	—	—	—	—
MHF2-20D2	Open	—	—	—	—
	Close	—	—	—	—

Note) There is no protrusion for sections of the table with no values entered.

MHZ

MHF

MHL

MHR

MHK

MHS

MHC

MHT
-Z

MHY

MHW

-X□

MRHQ

MA

D-□



Series MHF2 Specific Product Precautions

Be sure to read before handling.

Mounting

Warning

1. Do not scratch or dent the air gripper by dropping or bumping it when mounting.

Slight deformation can cause inaccuracy or a malfunction.

2. Tighten the screw within the specified torque range when mounting the attachment.

Tightening with a torque above the limit can cause malfunction, while insufficient tightening can cause slippage and dropping.

How to Mount Attachment to the Finger

Make sure to mount the attachments on fingers with the tightening torque in the table below by using bolts, etc., for the female threads on fingers.

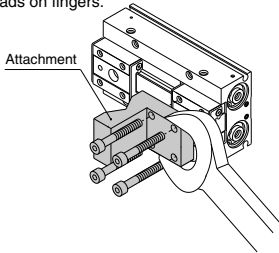

Model	Bolt	Max. tightening torque N-m
MHF2-8D□	M2.5 x 0.45	0.36
MHF2-12D□	M3 x 0.5	0.63
MHF2-16D□	M4 x 0.7	1.5
MHF2-20D□	M4 x 0.7	1.5

3. Tighten the screw within the specified torque range when mounting the air gripper.

Tightening with a torque above the limit can cause malfunction, while insufficient tightening can cause slippage and dropping.

How to Mount Air Grippers

Top mounting (Body tapped)

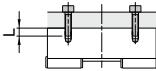

Model	Bolt	Max. tightening torque N-m	Max. screw-in depth L mm
MHF2-8D	M3 x 0.5	0.95	7
MHF2-12D	M4 x 0.7	2.2	10
MHF2-16D	M5 x 0.8	4.5	12
MHF2-20D	M6 x 1	7.8	15

Lateral mounting (Body tapped)

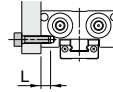

Model	Bolt	Max. tightening torque N-m	Max. screw-in depth L mm
MHF2-8D	M3 x 0.5	0.63	4
MHF2-12D	M4 x 0.7	1.5	5
MHF2-16D	M5 x 0.8	3	5.5
MHF2-20D	M6 x 1	5.2	6

Bottom mounting (Body tapped, body through-hole)

- Body tapped

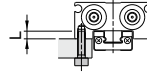

Model	Bolt	Max. tightening torque N-m	Max. screw-in depth L mm
MHF2-8D	M3 x 0.5	0.63	4
MHF2-12D	M4 x 0.7	1.5	5
MHF2-16D	M5 x 0.8	3	5.5
MHF2-20D	M6 x 1	5.2	6

- Body through-hole

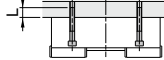

Model	Bolt	Max. tightening torque N-m	Screw-in depth L mm
MHF2-8D	M2.5 x 0.45*	0.36	4
MHF2-12D	M3 x 0.5*	0.63	5.2
MHF2-16D	M4 x 0.7	1.5	—
MHF2-20D	M5 x 0.8	3	—

* When MHF2-8D□ and MHF2-12D□ are mounted body through-hole, use the attached special bolts.

Operating Environment

Caution

Use caution for the anti-corrosiveness of the linear guide section.

Martensitic stainless steel is used for the finger guide rail, so make sure that anti-corrosiveness is inferior to the austenitic stainless steel. In particular, watch for rust in environments where waterdrops are likely to adhere due to condensation.