

Air Catch Sensor

Series ISA2

Non-Contact Sensor for Workpiece Placement Verification

The air catch sensor ISA2 series has been remodeled.
Click [here](#) for details.



Stable detection of 0.01 to 0.5 mm clearance

Due to the pneumatic bridge circuit and semiconductor pressure sensor, the non-contact type sensor is hardly affected by fluctuations in the supply pressure.

● Plug connectors (Centralized wiring)

Requires less man hours to wire.
Easy to add and remove manifold stations.

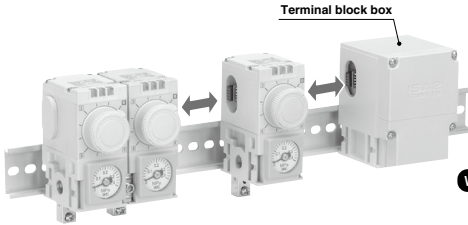

● Modular construction

Requires less man hours to wire.

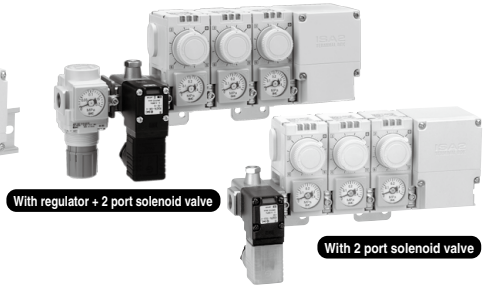

Check optimum position at a glance. LED level meter

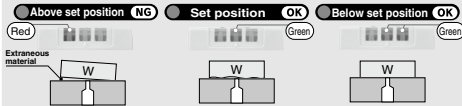

Easy-to-operate large dial

Scale provides guidelines for set position.

2 wiring methods

Individual wiring

Centralized Wiring

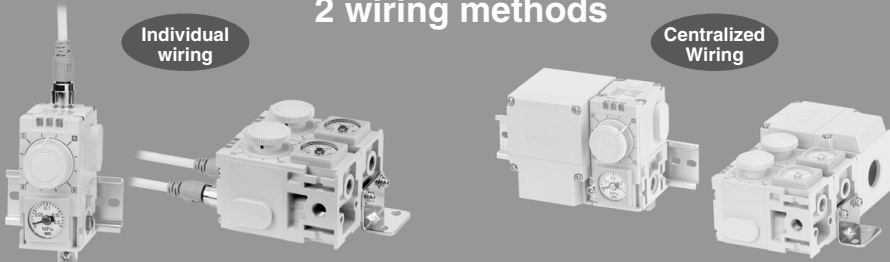

● Minimum operating pressure 30 kPa (ISA2-G)

Energy consumption can be reduced compared with the conventional models (Conventional models: 50 kPa)

● Position of supply port: Either right side or left side is available.

ZSE30
ISE30
ZSE40
ISE40
ZSE10
ISE10
ISE70
ZSE80
ISE80
ZSE□
ISE□
ZSP
PS
ISA2
PSE
IS
ISG
ZSM1

Air Catch Sensor Series ISA2



The air catch sensor ISA2 series has been remodeled.
Click [here](#) for details.

How to Order

Manifold

Without control unit

IISA2 N PL - 3 B

With control unit

IISA2 C SL - 3 B 1 D E2

Control unit

C	With regulator + 2 port solenoid valve
V	With 2 port solenoid valve

Electrical entry and supply port position

SR	Centralized wiring with supply port on the right
SL	Centralized wiring with supply port on the left
PR	Individual wiring with supply port on the right
PL	Individual wiring with supply port on the left

Note) The supply port position is the one when the switch is viewed from the front.

Stations

1	1 station
2	2 stations
3	3 stations
4	4 stations
5	5 stations
6	6 stations

Option

Nil	Without bracket
B	With bracket
D	With mounting bracket for DIN rail

Note) DIN rail must be ordered separately.
(Refer to page 879.)

Voltage of 2 port solenoid valve

1	100 VAC
2	200 VAC
3	110 VAC
4	220 VAC
5	24 VDC
6	12 VDC
36	230 VAC

Pressure gauge of regulator Note 1)

A*	Without pressure gauge <small>Note 2)</small>		
E2	MPa single notation	0.2	Square embedded pressure gauge
Z2	psi single notation	MPa	
E4	MPa single notation	0.4	Round pressure gauge
Z4	psi single notation	MPa	
G2	MPa single notation	0.2	Round pressure gauge
P2	MPa-psi double notation	MPa	
G4	MPa single notation	0.4	
P4	MPa-psi double notation	MPa	

Note 1) Due to new Japanese weight and measurement legislation, psi notation type cannot be sold or used in Japan.

Note 2) The pressure gauge port is Rc 1/8.

* Produced upon receipt of order

Throttle/Manual lock of 2 port solenoid valve

Nil	Without throttle, without manual lock
C	With throttle, without manual lock
W	Without throttle, with manual lock
M	With throttle, with manual lock

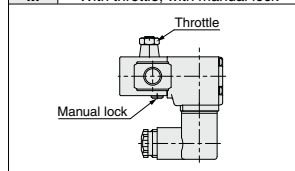

Electrical entry of 2 port solenoid valve

D : DIN connector	D0 : DIN connector (Without connector)	T : Conduit terminal
DL : DIN connector (With indicator light)		TL : Conduit terminal (With indicator light)

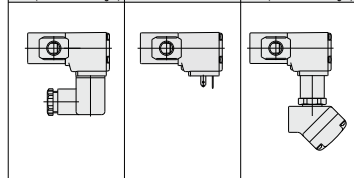

How to Order

The air catch sensor ISA2 series has been remodeled. Click [here](#) for details.



For single and double notation type and additional stations

Air catch sensor

ISA2 - G E2 1

Detection distance

G	0.01 to 0.25 mm
H	0.03 to 0.5 mm

Piping specifications

Nil	Rc 1/8
N	NPT 1/8
F*	G 1/8 *1

* Produced upon receipt of order
*1 According to ISO228-1

Pressure gauge Note 1)

A*	Without pressure gauge <small>Note 2)</small>	
E2	MPa single notation	0.2
Z2*	psi single notation	MPa
E4	MPa single notation	0.4
Z4*	psi single notation	MPa
G2	MPa single notation	0.2
P2*	MPa-psi double notation	MPa
G4	MPa single notation	0.4
P4*	MPa-psi double notation	MPa

Note 1) Due to new Japanese weight and measurement legislation, psi notation type cannot be sold or used in Japan.

Note 2) The pressure gauge port is Rc 1/8.
* Produced upon receipt of order

Output specifications

1	NPN output
5	PNP output

Electrical entry

Individual wiring	Nil	Straight
	L*	Right angle
	N	Without lead wire
Centralized wiring	P	Terminal block box

* Produced upon receipt of order

Ordering Example

Without control unit

Centralized wiring

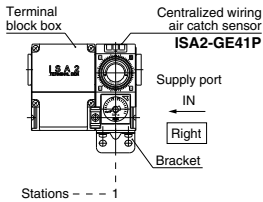

IISA2NSR-1B ... 1 set (1 station manifold part number)
ISA2-GE41P ... 1 set (Air catch sensor part number)
* Prefix the part number of the air catch sensor with an asterisk (*).

Individual wiring

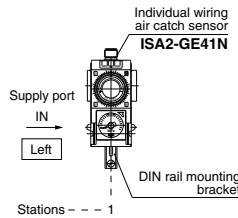

IISA2NPL-1D ... 1 set (1 station manifold part number)
ISA2-GE41N ... 1 set (Air catch sensor part number)
* Prefix the part number of the air catch sensor with an asterisk (*).

Centralized wiring/Supply port right

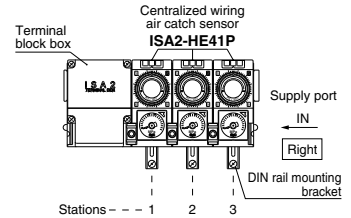

IISA2NSR-3D ... 1 set (3 stations manifold part number)
ISA2-HE41P ... 3 sets (Air catch sensor part number)
* Prefix the part number of the air catch sensor with an asterisk (*).

With control unit

Centralized wiring/Supply port left

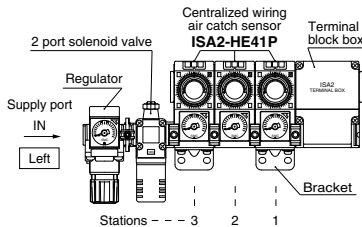

IISA2CSL-3B5DLC2E ... 1 set (3 stations manifold part number)
ISA2-HE41P ... 3 sets (Air catch sensor part number)
* Prefix the part number of the air catch sensor with an asterisk (*).

Individual wiring/Supply port right

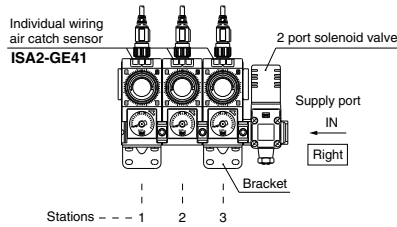

IISA2VPR-3B5DLC ... 1 set (3 stations manifold part number)
ISA2-GE41 ... 3 sets (Air catch sensor part number)
* Prefix the part number of the air catch sensor with an asterisk (*).

ZSE30
ISE30
ZSE40
ISE40
ZSE10
ISE10
ISE70
ZSE80
ISE80
ZSE
ISE
ZSP
PS
ISA2
PSE
IS
ISG
ZSM1

For details about the Pressure Switch Precautions, refer to pages 763 and 764. For details about the Specific Product Precautions, refer to the Operation Manual at SMC website. Click [here](#) for details.

Specifications

Model	ISA2-G□□□1□	ISA2-G□□□5□	ISA2-H□□□1□	ISA2-H□□□5□
Detection distance	0.01 to 0.25 mm		0.03 to 0.50 mm	
Fluid	Dry air (filtered to 5 μm)			
Operating pressure range	30 to 200 kPa		50 to 200 kPa	
Recommended detection nozzle	ø1.5		ø2.0	
Consumption flow rate L/min (ANR)	Supply pressure	50 kPa	5 or less	10 or less
		100 kPa	8 or less	15 or less
		200 kPa	12 or less	22 or less
Power supply voltage	12 to 24 VDC ±10%, Ripple (p-p) 10% or less (With power supply polarity protection)			
Current consumption	15 mA or less			
Switch output	NPN open collector: 1 output		PNP open collector: 1 output	
	Maximum load current		80 mA	
	Maximum load voltage		30 VDC (at NPN output)	
	Residual voltage		1.5 V or less (at 80 mA)	
	Output protection		Yes	
Repeatability (Including temperature characteristics)	0.01 mm or less (Detection distance range 0.01 to 0.15 mm, supply pressure 100 to 200 kPa)		0.01 mm or less (Detection distance range 0.03 to 0.15 mm, supply pressure 100 to 200 kPa)	
Hysteresis ^{Note 1)}	0.01 mm or less (Detection distance range 0.01 to 0.15 mm) / 0.01 mm or less (Detection distance range 0.03 to 0.15 mm)			
Indicator light	LED level meter ^{Note 2)} with 1 red, 2 green (Set value < detection distance: red, Set value = detection distance: green 1, Set value > detection distance: green 1 + green 2)			
Environment	Enclosure	IP66: without pressure gauge IP40: with pressure gauge		
	Operating temperature range	Operating: 0 to 60°C, Stored: -20 to 70°C (No condensation or freezing)		
	Operating humidity range	Operating/stored: 35 to 85%RH (No condensation)		
	Withstand voltage	1000 VAC (in 50/60 Hz) for 1 minute between terminals and housing		
	Insulation resistance	2 MΩ or more (500 VDC measured via megohmmeter) between terminals and housing		
Port size	Nil: Rc 1/8, N type: NPT 1/8, F type: G 1/8			
Lead wire with connector (Individual wiring type)	4 cores, oil-resistant cable (ø6, 5m) with M12 4-pin pre-wired connector, Conductor O.D.: 0.90 mm, Insulator O.D.: 1.72 mm			
Terminal block box (Centralized wiring type)	Front wiring (Electrical entry ø21)			
Weight	Individual wiring type (body only): 253 g, common wiring type (body only): 250 g, Terminal block box: 205 g, lead wire: 278 g, connecting bracket with sealing for additional station: 4 g			
Standards	CE, RoHS			

Note 1) Refer to "Relation between Nozzle Diameter and Detection Distance" (page 870) for hysteresis.

Note 2) Refer to "Setting Procedure" (page 872) for LED level meter.

Working Principle

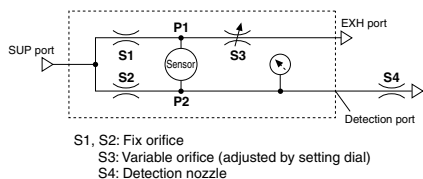

In a bridge circuit as in the left figure, a detection gap is applied to the detection nozzle (S4) while the setting dial S3 is adjusted to balance the pressure applied to the pressure sensor (P1 = P2). The pressure sensor detects the differential pressure generated when the detection nozzle (S4) is released. When the work piece comes close to the detection nozzle, the back pressure P2 increases until it is larger than P1 (P2 ≥ P1). Then the switch output turns on to notify that the pressure is below the detection gap.

Wiring

Individual wiring

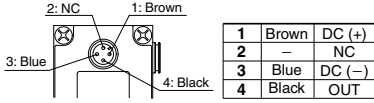

1. Insert the connector of the lead wire with its key groove at the proper position.
2. Hold the knuri with 2 fingers and rotate it clockwise. Do not use tools.

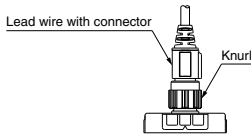

3. Connect the colored wires coming from the cable terminal.
Refer to the circuit diagram and table above to avoid mistakes.

Centralized wiring

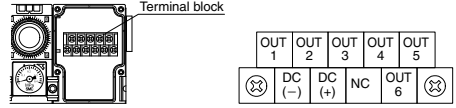

1. Mount the seal conduit on the terminal block box. For mounting procedure, refer to the catalog and operation manual provided by the manufacturer of the seal conduit.
2. Thread the cable through the seal conduit and arrange wiring according to the polarity of the terminal block illustrated above.
3. Fasten the seal conduit with a tightening torque not greater than 5 N·m. Do not hold the terminal block box or the switch.

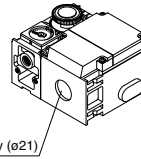

Internal Circuits and Wiring Examples

NPN (1 output)

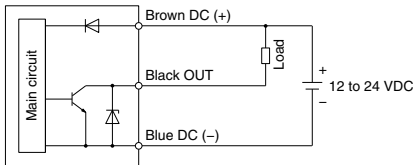

PNP (1 output)

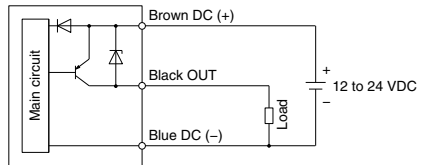

ZSE30
ISE30
ZSE40
ISE40
ZSE10
ISE10
ISE70
ZSE80
ISE80
ZSE
ISE
ZSP
PS
ISA2
PSE
IS
ISG
ZSM1

Relation between Detection Distance and Hysteresis (Typical example)

The data in the following charts are characteristics of hysteresis at the detection distance.

The smaller the hysteresis, the better the sensitivity. In cases where the hysteresis exceeds 0.01 mm, the air catch sensor should be used to check the presence of the workpiece.

ISA2-G□□□□□

Detection nozzle: $\phi 1.5$
Detection side piping: $\phi 6 \times \phi 4$ tubing 5 m

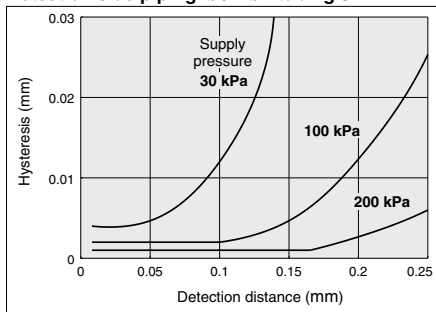

ISA2-H□□□□□

Detection nozzle: $\phi 2.0$
Detection side piping: $\phi 6 \times \phi 4$ tubing 5 m

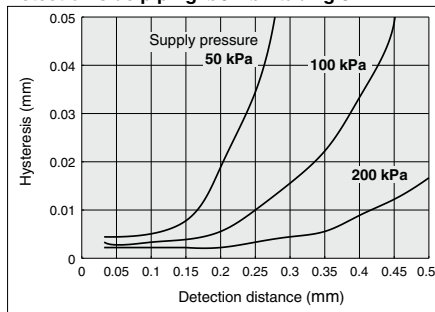

Supply Pressure Dependence (Typical example)

The charts illustrate changes in the detection distance with fluctuations in the supply pressure.

ISA2-G□□□□□

Standard pressure: 100 kPa
Detection nozzle: $\phi 1.5$
Detection side piping: $\phi 6 \times \phi 4$ tubing 5 m

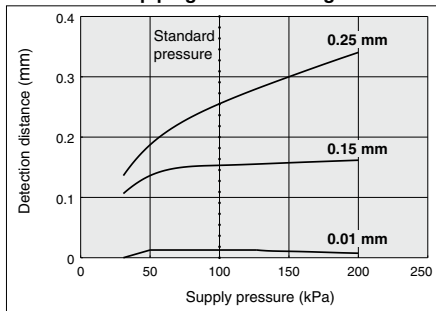

ISA2-H□□□□□

Standard pressure: 100 kPa
Detection nozzle: $\phi 2.0$
Detection side piping: $\phi 6 \times \phi 4$ tubing 5 m

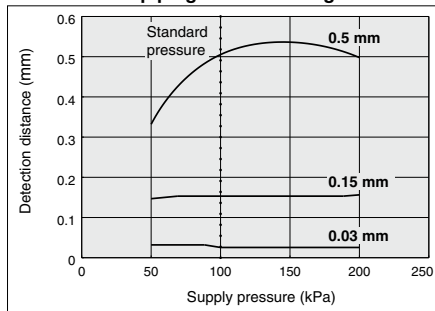

Response Time (Typical example)

Response time changes with detection distance and piping length.

While all graphs assume a fixed set distance with changes in the detection distance, the upper charts show responses at various set values and the lower charts show responses at various piping lengths. The response time becomes quicker as the set value becomes larger. Additionally, the response time becomes quicker as the piping length becomes shorter.

ISA2-G□□□□□

ISA2-H□□□□□

Detection nozzle: $\phi 1.5$ Supply pressure: 100 kPa
Detection side piping: $\phi 6 \times \phi 4$ tubing 5 m

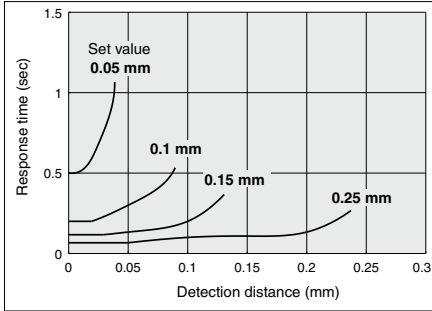

Detection distance – Response time characteristics

Detection nozzle: $\phi 2.0$ Supply pressure: 100 kPa
Detection side piping: $\phi 6 \times \phi 4$ tubing 5 m

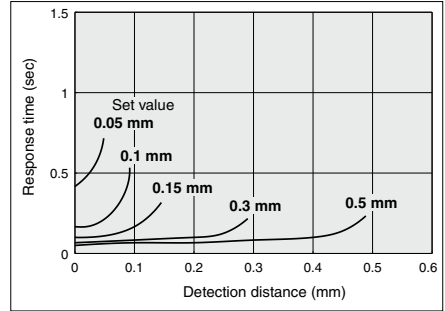

Detection distance – Response time characteristics

Detection nozzle: $\phi 1.5$ Supply pressure: 100 kPa
Detection side piping: $\phi 6 \times \phi 4$ Set distance: 0.15 mm

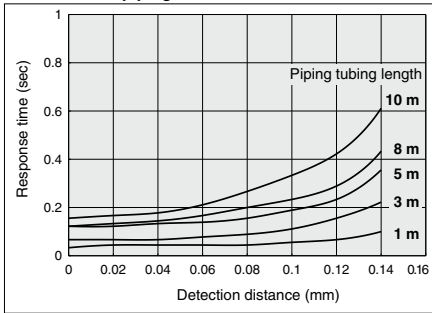

Piping tubing length – Response time

Detection nozzle: $\phi 2.0$ Supply pressure: 100 kPa
Detection side piping: $\phi 6 \times \phi 4$ Set distance: 0.3 mm

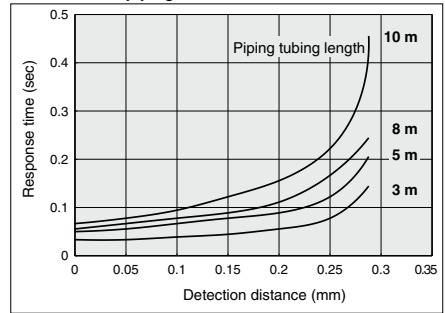

Piping tubing length – Response time

Nozzle Shape

Please keep the nozzle shape as illustrated below.

Take every caution against chamfer on the detection surface and/or nozzle hole, which could affect the characteristics as illustrated in Figure (1).

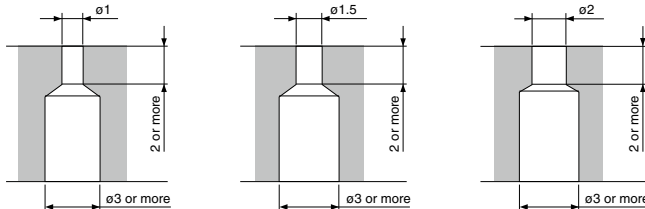
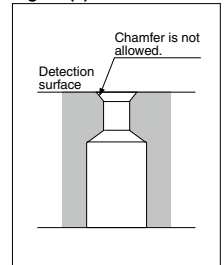

Figure (1)



ZSE30
ISE30
ZSE40
ISE40
ZSE10
ISE10
ISE70
ZSE80
ISE80
ZSE□
ISE□
ZSP
PS
ISA2
PSE
IS
ISG
ZSM1

Setting Procedure

The detection distance is set with the LED level meter and setting dial.
Keep the setting dial pulled out while in use. If released, it will return to its original position and become unable to rotate.

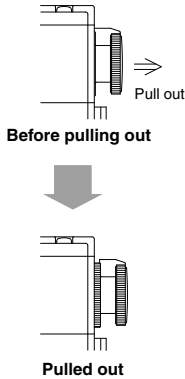

1. For accuracy in setting, apply a clearance gauge to the detection nozzle to replicate the set condition in advance.
2. Confirm that the set pressure is applied. If the setting dial is fully open, the LED level meter appears as (Light OFF).
3. Pull the setting dial and rotate it in the positive direction. The lights will turn on in the order shown below.

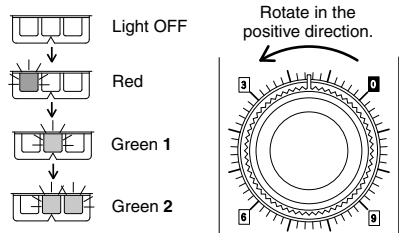

4. The sensor output comes on when the lights on the LED level meter turn on as Complete the setting when this condition is observed.
5. Apply the clearance gauge again to confirm that the lights turn on as .

Handling and setting of 2 port solenoid valve

Throttle setting for blowing to prevent water and cutting oil from entering the nozzle.
(Clockwise: Close throttle; Counterclockwise: Open throttle)

* The setting is not applicable to valves without throttle.

1. Power off the valve.
2. Rotate the throttle clockwise for adjustment so that the detection nozzle will not suck up water or cutting oil.

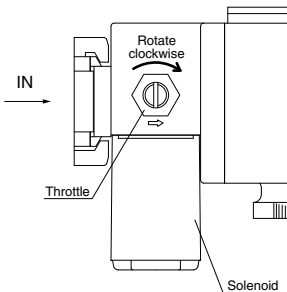

3. Power on the valve, then off again.
Confirm that the detection nozzle does not suck up water or cutting oil.
Note) Do not rotate the throttle more than 5 turns or it will fall out.

Handling and setting of limit gauge indicator

1. Removal of cover

Hook the finger on the front cover ridge and rotate it in the direction of the OPEN arrow until it stops (15°). Then pull out and remove the cover.

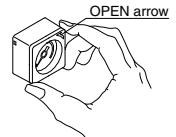

2. Setting the installation needle

The installation needle should be moved by the fingertip. Set the 2 green installation needles at the maximum and minimum limits of pressure.

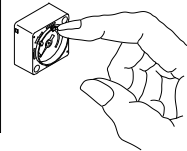
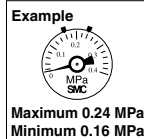

3. Installation of cover

After setting the installation needles, locate the OPEN arrow at the top right position and insert the claws on the cover into the grooves on the case (indicated by ▼ in the expanded view of A part). Rotate the cover clockwise until it stops. Confirm that the cover is firmly secured.

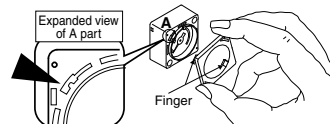

Relation between Dial Scale and Detection Distance (Typical example)

Test procedure and conditions

Dial scales when the detection nozzle is under the following conditions;

Supplied pressure: 100 kPa

Piping: $\phi 6 \times \phi 4$ tubing, 5 m in length.

Detection nozzle: ISA2-G□... $\phi 1.5$

ISA2-H□... $\phi 2.0$

Results of measurement ^{Note 1)}

● Relation between the detection distance and set dial scales ^{Note 2)} (Scale numbers)

ISA2-G□

Detection distance	Set dial scales
0.05 mm	1.2 to 1.6
0.10 mm	2.6 to 3.0
0.15 mm	3.9 to 4.5
0.20 mm	5.0 to 6.0
0.25 mm	6.1 to 7.7

ISA2-H□

Detection distance	Set dial scales
0.1 mm	2.9 to 3.7
0.2 mm	5.9 to 6.9
0.3 mm	7.8 to 9.0
0.4 mm	9.0 to 10.6
0.5 mm	9.3 to 11.3

● Average variation per scale (Detection distance [mm])

ISA2-G□ (Detection nozzle: $\phi 1.5$)

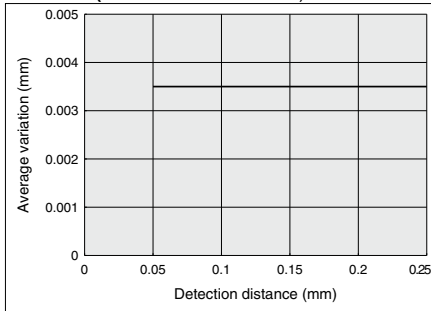

ISA2-H□ (Detection nozzle: $\phi 2.0$)

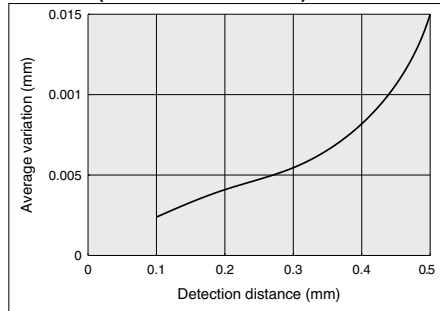

Note 1) This data provides reference values as a guide only, this should not be viewed as a guarantee of our products performance.

Note 2) Set dial scales are as follows;

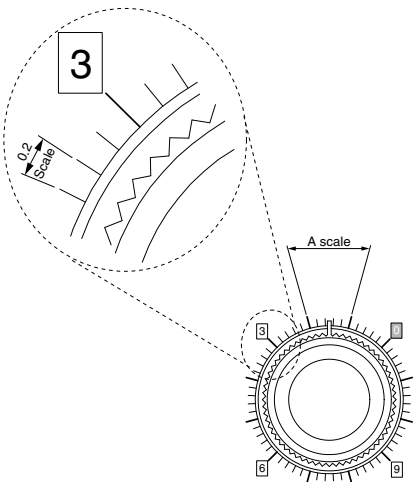

Between each major scales, it is sub divided into ten smaller settings (for example, between 2.0 to 3.0—2.1, 2.2, 2.3, etc.), settings are possible at 0.1 scale.

Series ISA2

Dimensions: Centralized Wiring Type

* When the SUP port is on the left, the stations are sequentially numbered from the side of the terminal block box.

With bracket

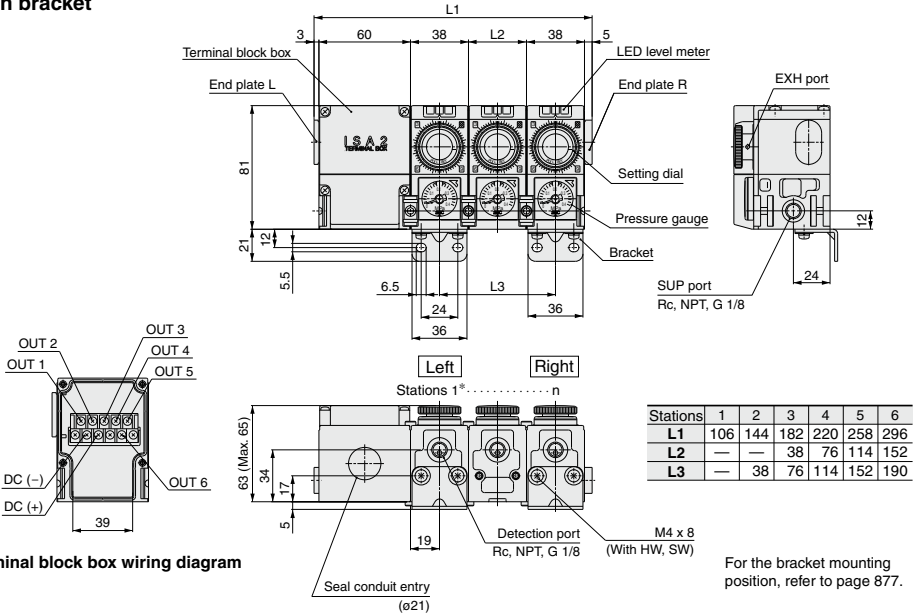

Terminal block box wiring diagram

With DIN rail

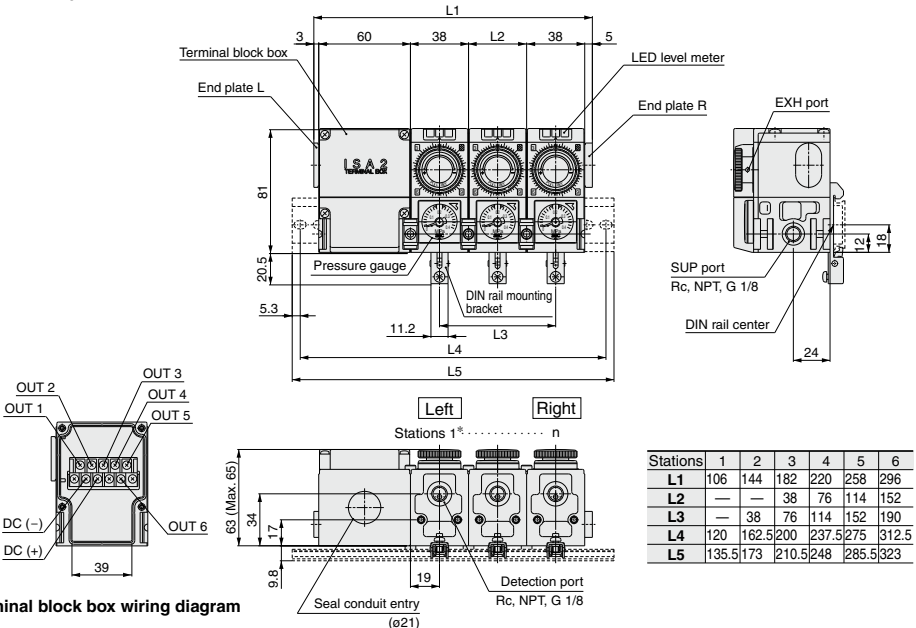

Terminal block box wiring diagram

Dimensions: Individual Wiring Type

With bracket

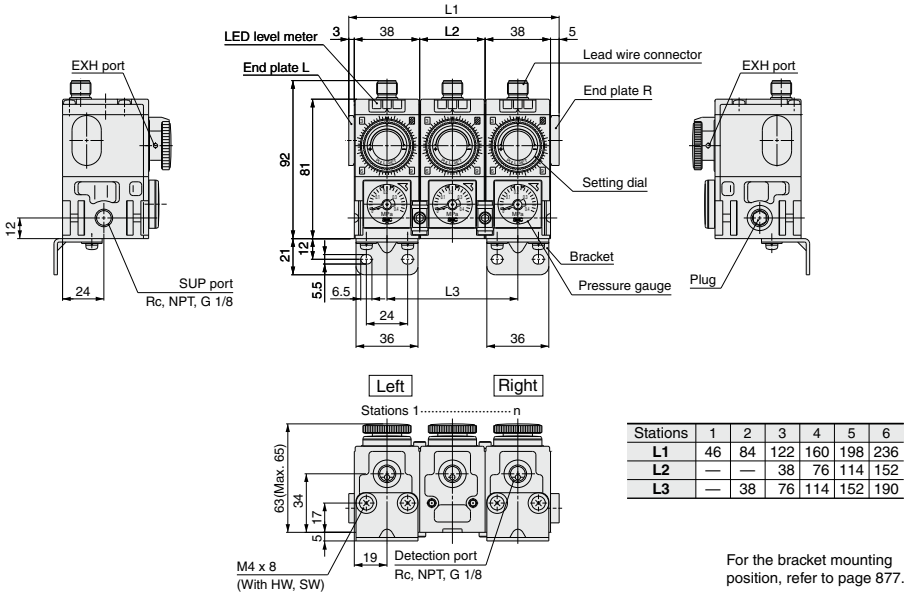

ZSE30
ISE30
ZSE40
ISE40
ZSE10
ISE10
ISE70
ZSE80
ISE80
ZSE
ISE
ZSP
PS
ISA2
PSE
IS
ISG
ZSM1

For the bracket mounting position, refer to page 877.

With DIN rail

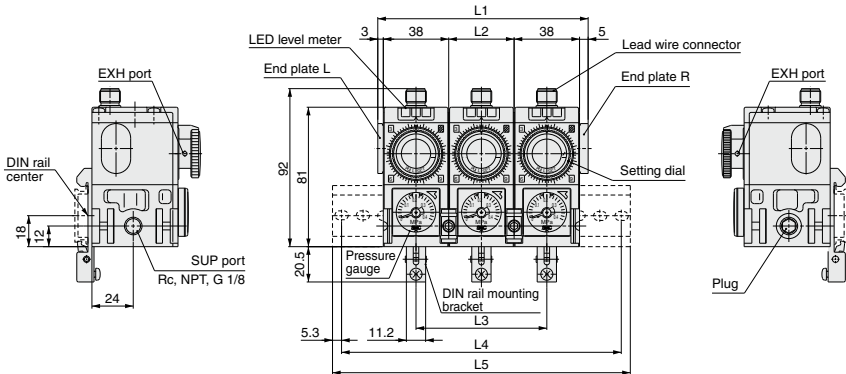

Electrical entry dimensions

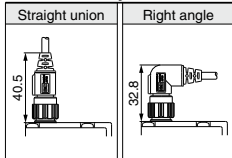

The direction of a right angle connector cannot be changed.

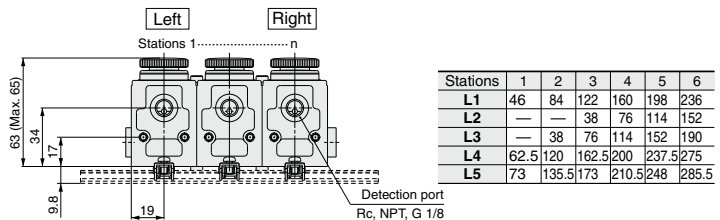

Series ISA2

Dimensions: With Control Unit

SUP port on the left

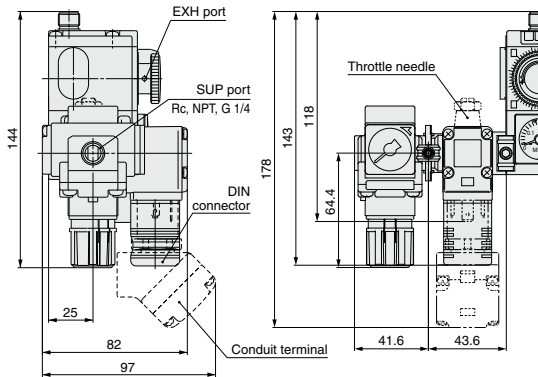

With regulator + 2 port solenoid valve

With 2 port solenoid valve

SUP port on the right

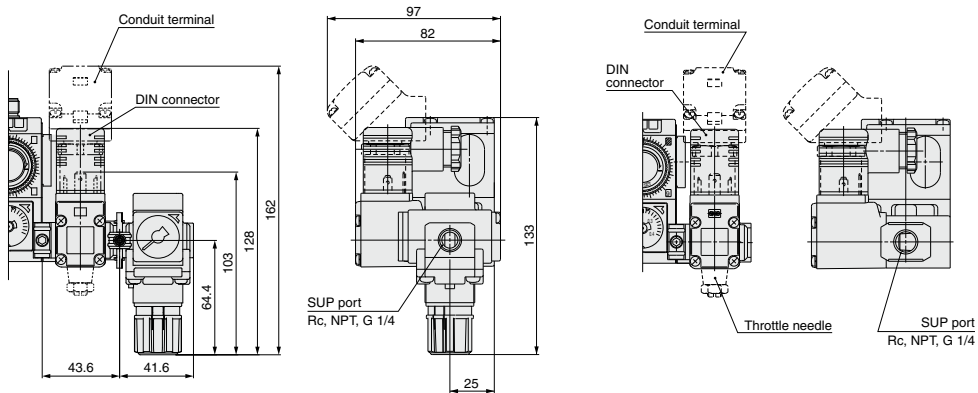

With regulator + 2 port solenoid valve

With 2 port solenoid valve

Lead wire with connector ISA-8-A

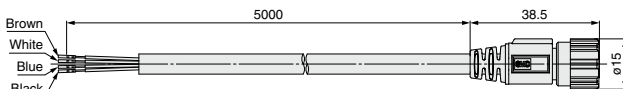

Lead wire with connector ISA-8-B

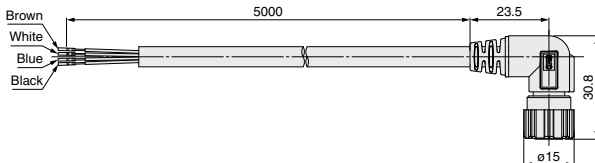

Bracket Mounting Position

With 2 stations, the bracket is mounted on the second sensor from the left.

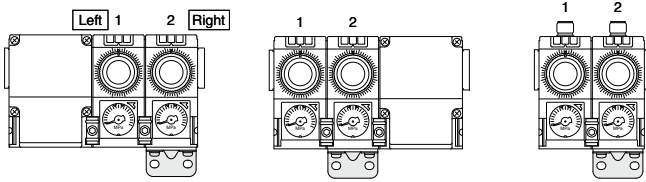

With n stations, the bracket is mounted on the first and “n”th sensor from the left.

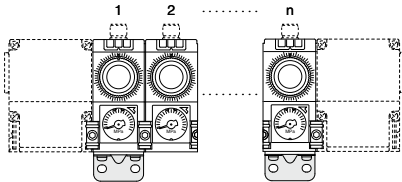

Addition of Manifold Stations

1. Disassembly

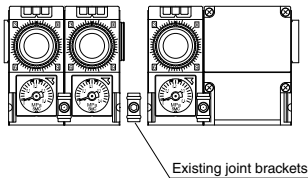

1. Loosen the screws and remove the 2 mounting brackets on the front and back side.
2. Disassemble the switch carefully so that the O-ring on the SUP port will not be detached.

End plate removal

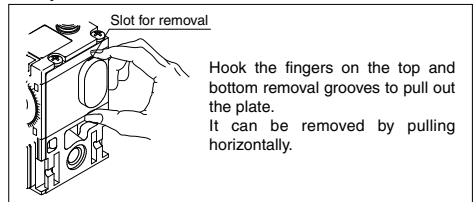

2. Insertion

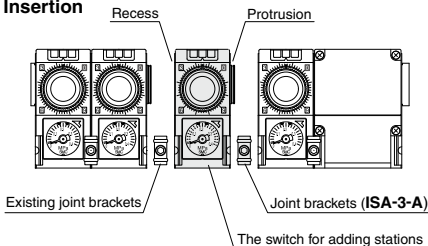

1. Fit seal for additional station (**ISA-7-B**) to the recess of the SUP port of the additional switch.
2. Fit the protrusion of the additional switch into the existing switch.
3. Mount joint brackets (**ISA-3-A**) at 2 positions.
Note) Perform temporary tightening of screws.
4. Confirm that the recess of the SUP port of the existing switch has seal for additional station attached.
5. Fit the protrusion of the existing switch into the recess of the additional switch.
6. Mount the existing joint bracket.
Note) Perform temporary tightening of screws.

3. Assembly

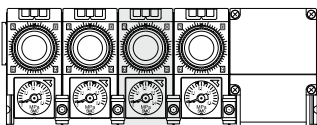

1. Tighten the joint brackets with the prescribed tightening torque of 1.2 N·m.
2. Arrange pneumatic piping and confirm that there is no air leakage from new joints.

ZSE30
ISE30
ZSE40
ISE40
ZSE10
ISE10
ISE70
ZSE80
ISE80
ZSE
ISE
ZSP
PS
ISA2
PSE
IS
ISG
ZSM1

Series ISA2

Parts List

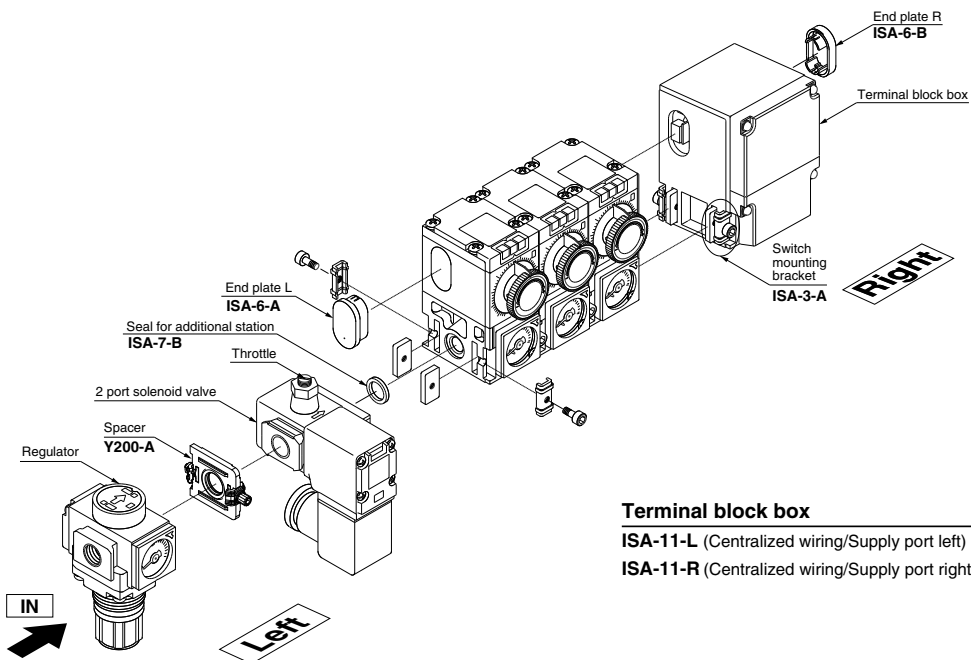

Terminal block box

ISA-11-L (Centralized wiring/Supply port left)

ISA-11-R (Centralized wiring/Supply port right)

Spacer

Y200-A



Seal for additional station

ISA-7-B

When 2 air catch sensors are connected or when a 2 port solenoid valve is connected to the left:



ISA-7-A

When a 2 port solenoid valve is connected to the right:



End plate L

ISA-6-A



End plate R

ISA-6-B



Joint bracket

ISA-3-A

A pair consists 1 set.



Lead wire with connector (Individual wiring type)

ISA-8-A

Straight, 5 m



ISA-8-B

Right angle, 5 m

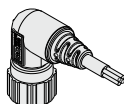

Bracket

ISA-4-A

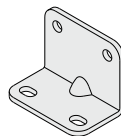

With mounting screw 2 pcs.

DIN rail mounting bracket

ISA-9-A



DIN Rail

ISA-5-□

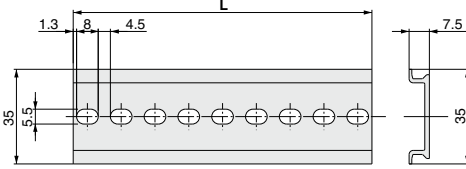

Part no.	L	Applicable models	
		Individual wiring type	Centralized wiring type
ISA-5-1	73.0	IISA2□P□-1	—
ISA-5-2	135.5	IISA2□P□-2	IISA2□S□-1
ISA-5-3	173.0	IISA2□P□-3	IISA2□S□-2
ISA-5-4	210.5	IISA2□P□-4	IISA2□S□-3
ISA-5-5	248.0	IISA2□P□-5	IISA2□S□-4
ISA-5-6	285.5	IISA2□P□-6	IISA2□S□-5
ISA-5-7	323.0	—	IISA2□S□-6

Pressure Gauge for Air Catch Sensor

Square embedded pressure gauge

GC3-□ 4 AS

Notation specifications		Maximum pressure indication	
Nil	MPa single notation	2	0.2 MPa
P	psi single notation	4	0.4 MPa



Round pressure gauge

G36-□ 4- 01

Notation specifications		Maximum pressure indication	
Nil	MPa single notation	2	0.2 MPa
P ^{Note)}	MPa-psi double notation	4	0.4 MPa

Note) For double notation of MPa and psi, add "-X30" at the end of part number.
Example) G36-P4-01-X30

Connection thread	
Nil	R 1/8
P	NPT 1/8

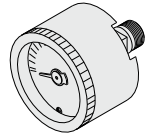

Regulator

AR 20-□ 02 □ -1 □ -B □

Thread type

Nil	Rc
N	NPT
F	G

Semi-standard specification

Nil	None
R	Flow direction: Right to left

Max. display pressure of the pressure gauge

Nil	0.4 MPa
-X2105	0.2 MPa

Option (The shape of pressure gauge)

Nil	Without pressure gauge
E	Square embedded pressure gauge (With limit indicator, MPa single notation)
G ^{Note)}	Round pressure gauge (With limit indicator, MPa single notation)
P ^{Note)}	Round pressure gauge (With limit indicator, MPa-psi double notation)

Note) The pressure gauge port is 1/8. The pressure gauge is included in the package (not assembled).

* When a regulator with square embedded pressure gauge (psi single notation) is required, change the part number suffix to "-X2175".
Example) AR20-02E-1-B-X2175

* Under the New Measurement Law, this type is only sold outside Japan. (The SI unit is used inside Japan.)

Standard Specifications

Model	AR20-B (-X2105)
Port size	1/4
Gauge port size ^{Note)}	1/8
Fluid	Air
Ambient and fluid temperature	-5 to 60°C (No freezing)
Proof pressure	1.5 MPa
Maximum operating pressure	1.0 MPa
Set pressure range	0.02 to 0.2 MPa
Construction	Relieving type
Weight (kg)	0.16

Note) The type with square embedded pressure gauge does not have connection.

2 Port Solenoid Valve

VCA27A-5 DL S-4-02-Q

Voltage

1	100 VAC
2	200 VAC
3	110 VAC
4	220 VAC
5	24 VDC
6	12 VDC
36	230 VAC

Port size

02	Rc 1/4
02N	NPT 1/4
02F	G 1/4

CE compliant

Throttle

Nil	Without throttle and manual lock
S	With throttle
B	With manual lock
K	With manual lock and throttle

Electrical entry

D	DIN connector
DL	DIN connector (With light)
DO	DIN connector (Without connector)
T	Conduit terminal
TL	Conduit terminal (With light)

Standard Specifications

Valve specifications	Valve type	Direct operation poppet
	Fluid	Air, Inert gas
	Withstand pressure MPa	2.0
	Body material	Al
	Seal material	HNBR
	Ambient temperature °C	-20 to 60
	Fluid temperature °C	-10 to 60 (No freezing)
	Enclosure	Dustproof and jetproof (Equivalent to IP65)
	Atmosphere	Environment with no corrosive or explosive gas
	Valve leakage cm ³ /min (ANR)	0.2 or less
Coil specifications	Mounting orientation	Free
	Vibration resistance/impact resistance m/s ² (Non-2)	30/150 or less
	Rated voltage	24/12 VDC, 100/110/200/220 VAC (50/60 Hz)
	Allowable voltage fluctuation	±10% rated voltage
	Type of coil insulation	B type
	Power consumption DC	VCA2: 6.5 W
	Apparent power	Note 1) 50 Hz AC 60 Hz
	VCA2: 7.5 VA	

Note 1) Since the AC specifications include a rectifying device, there is no difference between the apparent power required for starting and holding.

Note 2) Vibration resistance: No malfunction resulted in a one-sweep test in a 10 to 300 Hz range in the axial and right angle directions of the main valve and armature, for both energized and de-energized states.

Shock resistance: No malfunction resulted in an impact test using a drop impact tester. The test was performed in the axial and right angle directions of the main valve and armature, for both energized and de-energized states.