



## Electric Stopper Cylinder LEBQ Series

SMC CORPORATION  
4-14-1, SOTO-KANDA, CHIYODA-KU,  
TOKYO 101-0021, JAPAN  
URL: <http://www.smcworld.com>

### Suitable for conveyor lines without an air supply

<Application Example>

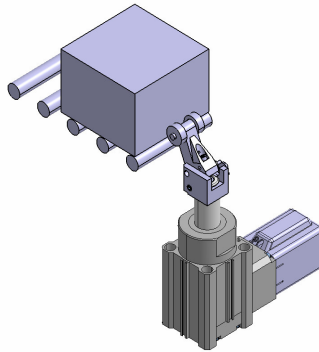

- **Rod end shape**  
Chamfered type, roller type and lever type are available.



- **Energy saving: power consumption at rod stoppage is reduced by 60%.**
- **Height and mounting**  
Compatible with Stopper Cylinder **RSQ** series

# ● Easy setting

## Easy adjustment on site with the programless controller

- No programming is required.
- Speed, acceleration and position can be set easily with the trimmer switch on the operation panel.
- No PC or Teaching Box is required.
- 16 gradual adjustments for speed and acceleration
- 14 positioning points
- Applicable to motors with lock
- Applicable to electric actuators with vertical specifications
- Applicable to Electric Actuator LE series

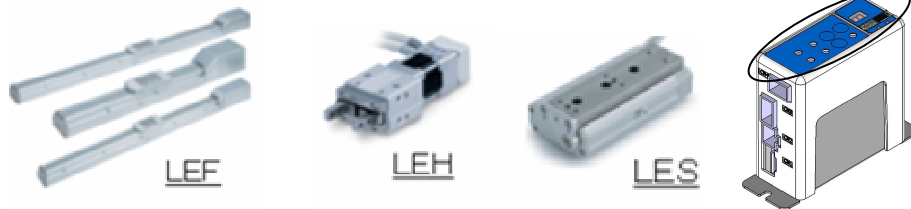
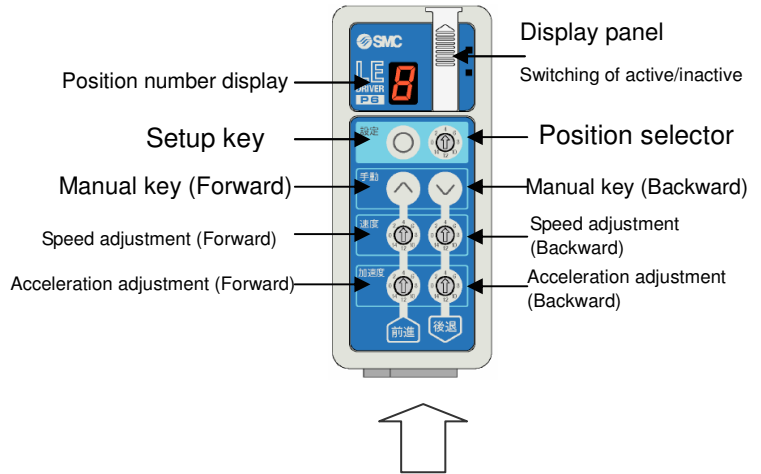

LEC series controllers that are capable of detailed settings are also applicable to this stopper cylinder.

## ■ How to Order

**LEBQ B 32 □ - 20 □ □ - □ 1 6N 1 □ -X1**

Mounting brackets

<b>B</b>	Through-hole
<b>A</b>	Both ends tapped

Body size

<b>32</b>	32
<b>50</b>	50

Stroke

<b>20</b>	20
<b>30</b>	30

\*Body size 32: 20 stroke only  
\*Body size 50: 30 stroke only

※Rod chamfer orientation

<b>M</b>	Motor side
<b>R</b>	Right
<b>L</b>	Left
<b>E</b>	Opposite side of motor

Rod end shape

	Rod end shape	Application
<b>K</b>	Chamfered type	-
<b>R</b>	Roller type	-
<b>L</b>	Lever type (Non-adjustable)	Basic style
<b>B</b>	Lever type (energy absorbing adjustable)	-
<b>C</b>		With cancel cap
<b>D</b>		With lock mechanism
<b>E</b>		With lock + cancel

Motor cover option

<b>Nil</b>	Without option
<b>C</b>	With motor cover

Controller mounting

<b>Nil</b>	Screw mounting
<b>D</b>	DIN rail mounting

I/O cable length

<b>Nil</b>	Without cable
<b>1</b>	1.5 m
<b>3</b>	3 m
<b>5</b>	5 m

Controller type※

<b>Nil</b>	Without controller
<b>6N</b>	With controller (NPN)
<b>6P</b>	With controller (PNP)
<b>1N</b>	With program-less controller (NPN)
<b>1P</b>	With program-less controller (PNP)

※Programming-less controller is incompatible with DIN rail mounting.

Actuator cable length

<b>Nil</b>	Without cable	<b>8</b>	8 m※
<b>1</b>	1.5 m	<b>A</b>	10 m※
<b>3</b>	3 m	<b>B</b>	15 m※
<b>5</b>	5 m	<b>C</b>	20 m※

Actuator cable type※Produced upon receipt of order

<b>Nil</b>	Without cable
<b>S</b>	Standard cable
<b>R</b>	Robotic cable (Flexible cable)

## Specifications:

Model		LEBQ32	LEBQ50
Actuator specifications	Stroke (mm)	20	30
	Force (N)	30	150
	Speed (mm/s)	80	135
	Screw lead (mm)	5	8
	Impact/Vibration resistance (m/sec <sup>2</sup> )	50/20	
	Actuation type	Sliding screw + Cam	
	Operating temp. range (°C)	5 to 40 (No freezing)	
	Operating humidity range (%)	35 to 85 (No freezing)	
Electric specifications	Motor size	□28	□42
	Motor type	Step motor (Servo 24 V DC)	
	Encoder (Angular displacement sensor)	Incremental A/B phase (800 pulse/rotation)	
	Rated voltage (V)	24 V DC ± 10%	
	Power consumption (W)	29	36
	Standby power consumption when operating (W)	10	15
	Momentary max. power consumption(W)	37	46
	Controller weight (kg)	LECP6	0.15 (Screw mounting), 0.17 (DIN rail mounting)
LECP1		0.13	

### Weight

(kg)

Rod end shape	LEBQ32	LEBQ50
Chamfered type, Roller type	0.81	1.76
Lever with a shock absorber built-in type	0.9	1.99

- ※ Power consumption means power consumption during operation including the controller.
- ※ Standby power consumption when operating means power consumption at standby during operation including that at power saving holding.
- ※ Momentary maximum power consumption means the maximum momentary electric power during operation including the controller. Use this to select power source capacity.

## ■ System Construction

### -In case of Program-less Controller (LECP1)

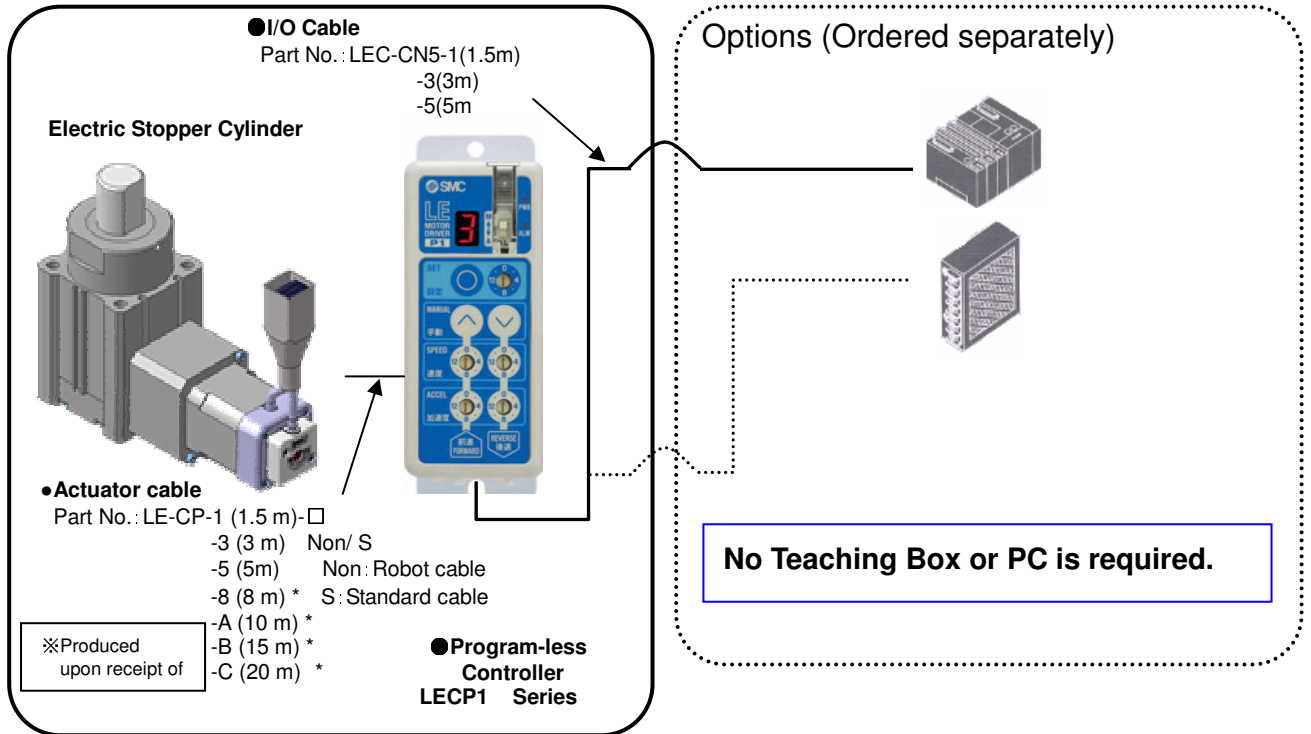

### -In case of Program Controller (LECP/A6)

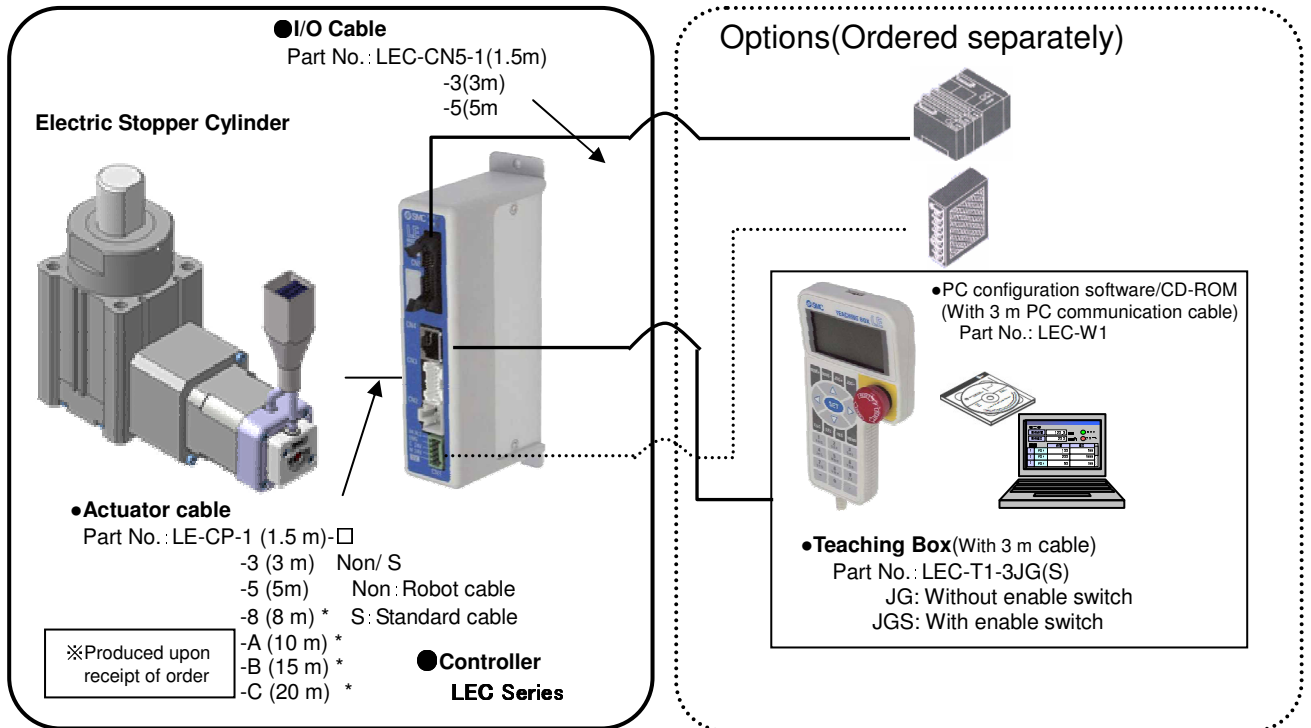

## ■ Dimensions: mm【LEBQ32】

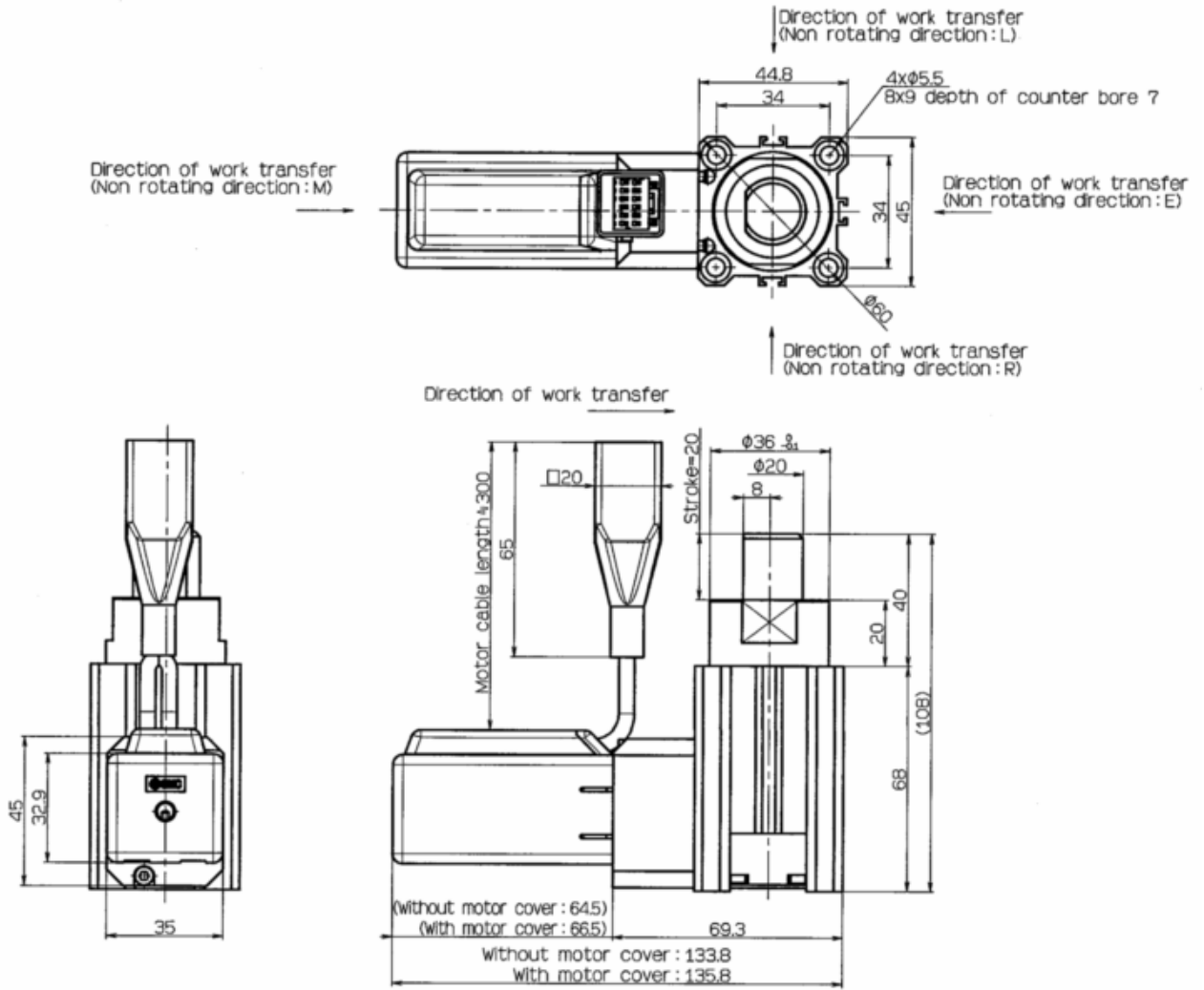
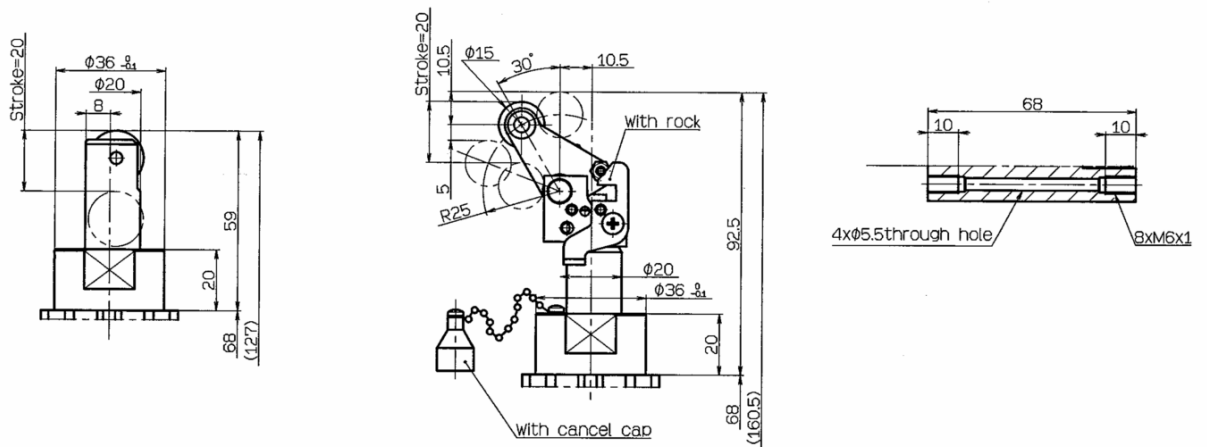

Fig.1  
Roller type  
(Rod end Configuration: R)

Fig.2  
Lever type  
(Rod end Configuration: L/B/C/D/E)

Fig.3  
Mounting bracket  
/Both ends tapped type



※The drawing shows the product with motor cover.

※The drawing shows the product with the rod chamfer facing the motor.

※The drawing shows the product with the chamfered type rod end. Refer to Fig.1 and Fig.2 for other specifications.

# ■ Dimensions: mm【LEBQ50】

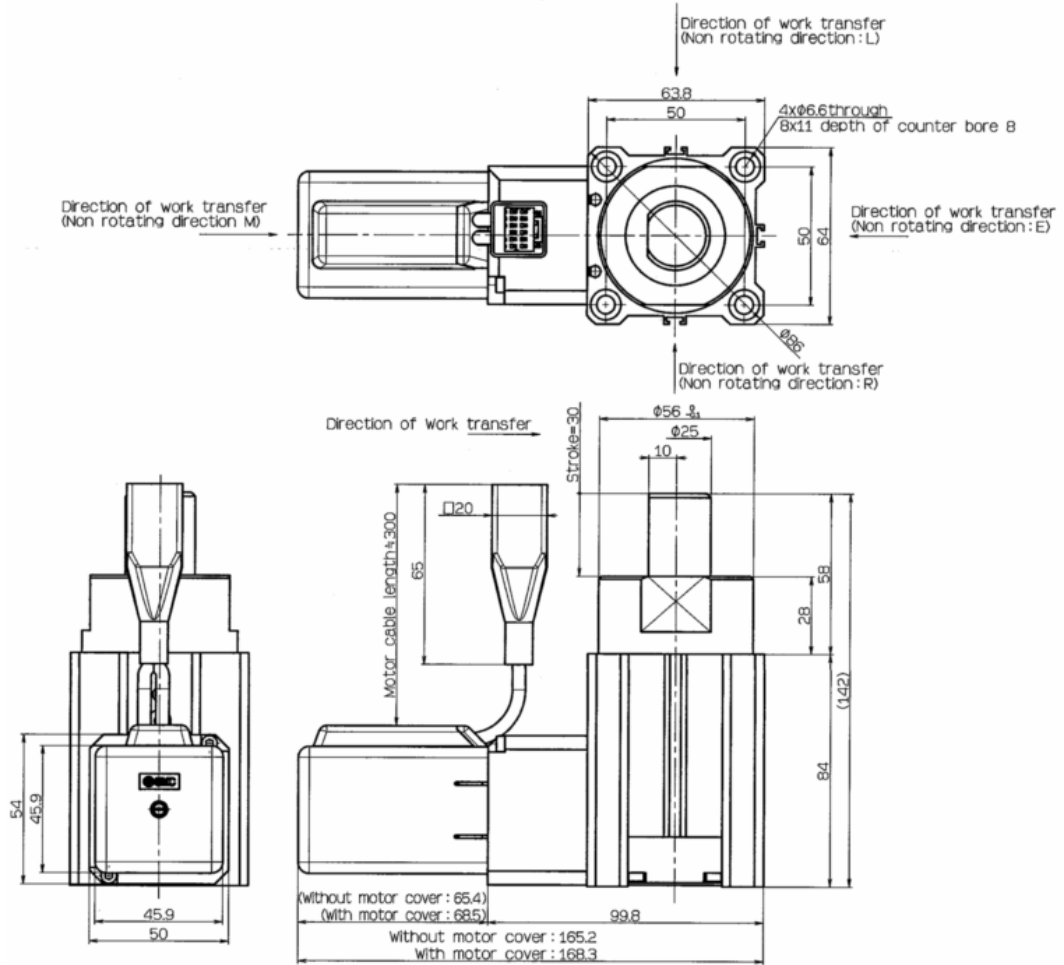

Fig.1  
Roller type  
(Rod end Configuration : R)

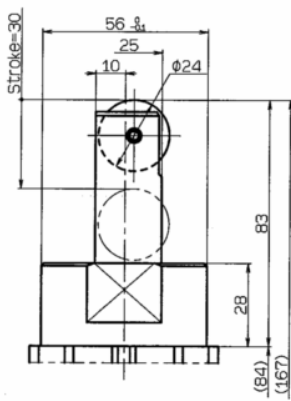

Fig.2  
Lever type  
(Rod end Configuration : L/B/C/D/E)

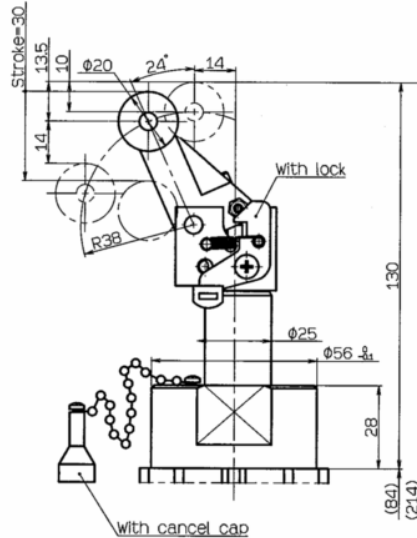
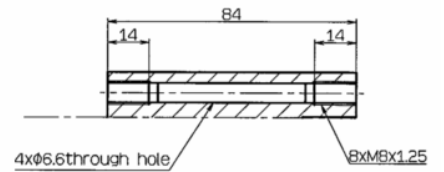

Fig.3  
Mounting bracket  
/Both ends tapped type



- ※The drawing shows the product with motor cover.
- ※The drawing shows the product with the rod chamfer facing the motor.
- ※The drawing shows the product with the chamfered type rod end. Refer to Fig.1 and Fig.2 for other specifications.

## ■ Operating range

Roller Type/Round Bar Type/Chamfered Type

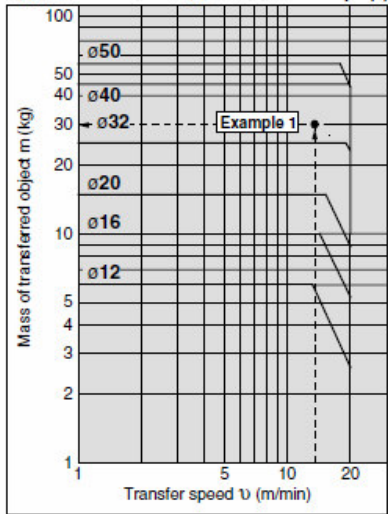

Lever Type (With shock absorber)  
Friction coefficient  $\mu = 0$

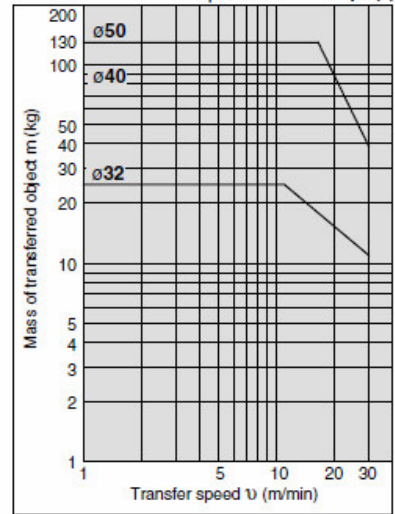

Lever Type (With shock absorber)  
Friction coefficient  $\mu = 0.1$

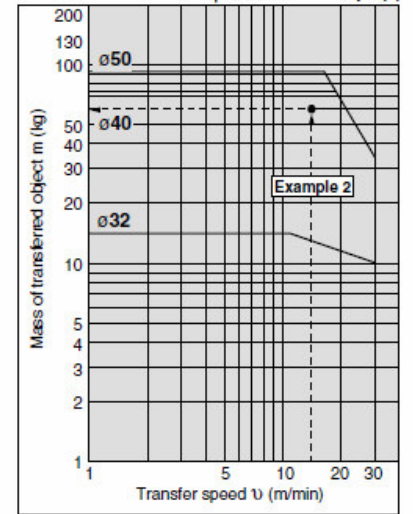

- Lever-type mass of transferred object and transfer speed graphs (graphs (2) and (3)) show the values at room temperature (20 to 25°C).
- When selecting cylinders, confirm the Specific Product Precautions as well.

## ■ Precautions

1. Since no magnet is mounted in this product, auto switches are not applicable.
2. In regard to the mass of the transferred object and the transfer speed, conform to the operating ranges.



**Caution** To ensure the safest possible operation of this product, please be sure to read thoroughly the "Safety Instructions" in our "Best Pneumatics" catalog before use.