

Series **KP** Clean One-touch Fittings For Blowing

RoHS



⚠ Caution

The KP series is a line of special One-touch fittings for use in clean room blowing and washing lines. Please consult with SMC regarding other types of applications.

Seal material: The durability of EPDM with respect to mineral oils is inferior, which makes it unsuitable for piping in general pneumatic equipment.

Applicable Tubing

Tubing material	PFA, Polyolefin Soft polyolefin, Polyurethane
Tubing O.D.	ø4, ø6, ø8, ø10, ø12

Note 1) FEP, nylon and soft nylon tubing, and tubing not compatible with the clean series can also be used. However, the degree of clean performance will be reduced.

Note 2) Due to the softness of polyurethane tubing, it may fold when being inserted. Hold the end of the tubing and insert it all the way in.

Specifications

Cleanliness class (ISO class)	Class 3 ^{Note 1)}
Fluid	Air, Nitrogen gas, Water, Deionized water (Pure water) ^{Note 2)}
Maximum operating pressure (20°C)	1 MPa ^{Note 3)}
Operating vacuum pressure	-100 kPa (10 Torr)
Proof pressure (20°C)	3 MPa
Ambient and fluid temperature	-20°C to 80°C
Threads	JIS B0203 (Taper thread for piping)

Note 1) Refer to particle generation classifications.

Note 2) The surge pressure must be under the maximum operating pressure.

Note 3) The maximum operating pressure is the value at 20°C. Refer to the operating pressure curve for other temperatures.

Note 4) Do not use the fittings with a leak tester or for vacuum retention because they are not guaranteed for zero leakage.



Made to Order
(Refer to page 1222 for details.)

Particulate Generation Classifications

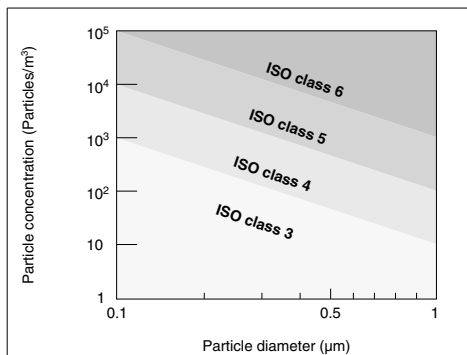

Note) Refer to page 17 for details.

Relation between Operating Temperature and Maximum Operating Pressure

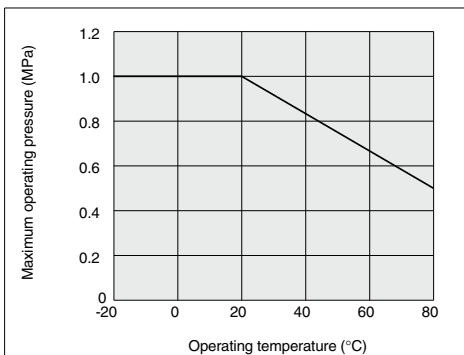

How to Order

Clean One-touch fittings (for blowing)

Model

H	Male connector, Straight union
L	Union elbow, Male elbow
T	Male branch tee, Union tee
Y	Male run tee
U	Male branch, Union "Y"
R	Plug-in reducer

Applicable tubing O.D.

04	ø4
06	ø6
08	ø8
10	ø10
12	ø12

Thread connection

01	R1/8
02	R1/4
03	R3/8
04	R1/2

Tubing (red) connection

00	Same dia. tubing
04	ø4
06	ø6
08	ø8
10	ø10
12	ø12

Different dia. tubing (plug-in reducer)

Made to Order

X53 With sealant tape

Port size/Applicable tubing O.D.

KP H 06 - 01 - []

KP P 08

Applicable fitting size

04	ø4
06	ø6
08	ø8
10	ø10
12	ø12

Plug

Clean One-touch fittings

Construction

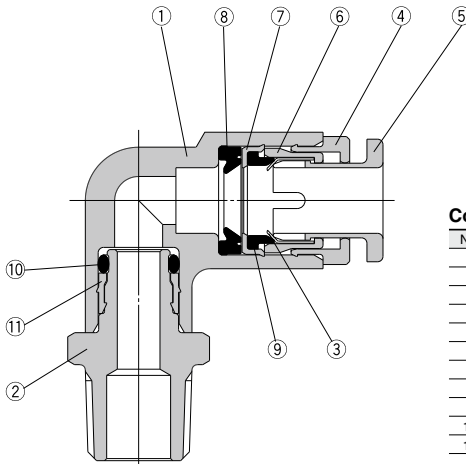

Component Parts

No.	Description	Material
1	Body	PP
2	Stud	PP
3	Chuck	Stainless steel 304
4	Guide	Stainless steel 304
5	Release button	PP (Color: Light green)
6	Collet	PP
7	Stopper	Stainless steel 304
8	Seal	EPDM (Fluorine-coated)
9	Bumper	EPDM (Fluorine-coated)
10	O-ring	EPDM (Fluorine-coated)
11	Drive bushing	Stainless steel 304

Directional Control Valves

Air Cylinders

Rotary Actuators

Air Grippers

Air Preparation Equipment

Modular F. R.

Pressure Control Equipment

Fittings & Tubing

Flow Control Equipment

Pressure Switches/ Pressure Sensors

Dimensions

Male Connector: KPH



Applicable tubing O.D. (mm)	Connection thread R	Model	H (width across flats)	L	A*	M	Effective area (mm ²)		Weight (g)
							TPH	TPS	
4	1/8	KPH04-01	12	24.4	20.5	17	4	4	3
	1/4	KPH04-02			18.5				4
6	1/8	KPH06-01	14	24.9	21	18.5	10	10	4
	1/4	KPH06-02			19.5				5
8	1/8	KPH08-01	17	31.3	27.5	20.5	26	18	6
	1/4	KPH08-02			23.5				7
10	1/4	KPH10-02	19	32	26	23	41	29	11
	3/8	KPH10-03			27				10
12	3/8	KPH12-03	22	33	27	24	58	46	12
	1/2	KPH12-04			26				13

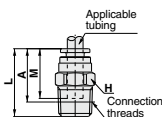

* Reference dimension for R threads after installation

Male Elbow: KPL



Applicable tubing O.D. (mm)	Connection thread R	Model	H (width across flats)	Note 1) ϕD_1	ϕD_2	L ₁	L ₂	A*	M	Effective area (mm ²)		Weight (g)
										TPH	TPS	
4	1/8	KPL04-01	12	10.4	10	19.7	23.2	24.5	17	3.5	3.5	4
	1/4	KPL04-02					27.2	26.5				5
6	1/8	KPL06-01	12	12.8	10	21.8	24.4	27	18.5	9	9	5
	1/4	KPL06-02					28.4	29				6
8	1/8	KPL08-01	14	15.2	12	25.3	26.6	30	20.5	22	15	8
	1/4	KPL08-02					29.4	31.5				9
10	1/4	KPL10-02	17	18.5	17	28.4	32.1	35.5	23	35	25	13
	3/8	KPL10-03					33.1	36.5				14
12	3/8	KPL12-03	22	20.9	22	30.4	34.3	38.5	24	50	40	15
	1/2	KPL12-04					38.3	41.5				18

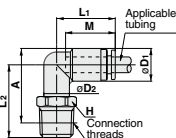

* Reference dimension for R threads after installation Note 1) ϕD_1 indicates the maximum diameter.

Male Branch Tee: KPT



Applicable tubing O.D. (mm)	Connection thread R	Model	H (width across flats)	Note 1) ϕD_1	ϕD_2	L ₁	L ₂	A*	M	Effective area (mm ²)		Weight (g)
										TPH	TPS	
4	1/8	KPT04-01	12	10.4	10	19.7	23.2	24.5	17	4.1	4.1	6
	1/4	KPT04-02					27.2	26.5				7
6	1/8	KPT06-01	12	12.8	10	21.8	24.4	27	18.5	11	11	8
	1/4	KPT06-02					28.4	29				9
8	1/8	KPT08-01	14	15.2	12	25.3	26.6	30	20.5	26.3	18.2	12
	1/4	KPT08-02					29.4	31.5				13
10	1/4	KPT10-02	17	18.5	17	28.4	32.1	35.5	23	40.8	29	20
	3/8	KPT10-03					33.1	36.5				21
12	3/8	KPT12-03	22	20.9	22	30.4	34.3	38.5	24	57.2	45.2	24
	1/2	KPT12-04					38.3	41.5				27

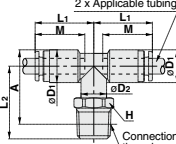

* Reference dimension for R threads after installation Note 1) ϕD_1 indicates the maximum diameter.

Male Run Tee: KPY



Applicable tubing O.D. (mm)	Connection thread R	Model	H (width across flats)	Note 1) ϕD_1	ϕD_2	L ₁	L ₂	A*	M	Effective area (mm ²)		Weight (g)
										TPH	TPS	
4	1/8	KPY04-01	12	10.4	10	19.7	23.2	39	17	7.5	7.5	6
	1/4	KPY04-02					27.2	41				7
6	1/8	KPY06-01	12	12.8	10	21.8	24.4	42	18.5	11	11	8
	1/4	KPY06-02					28.4	44.5				9
8	1/8	KPY08-01	14	15.2	12	25.3	26.6	48	20.5	21	21	12
	1/4	KPY08-02					29.4	49				13
10	1/4	KPY10-02	17	18.5	17	28.4	32.1	55	23	57	52	20
	3/8	KPY10-03					33.1	55.5				21
12	3/8	KPY12-03	22	20.9	22	30.4	34.3	58.5	24	57	57	24
	1/2	KPY12-04					38.3	61.5				24

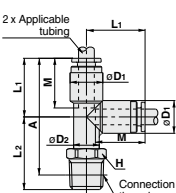

* Reference dimension for R threads after installation Note 1) ϕD_1 indicates the maximum diameter.

Male Branch "Y": KPU



Applicable tubing O.D. (mm)	Connection thread R	Model	H (width across flats)	Note 1) ϕD	L	P	A*	M	Effective area (mm ²)		Weight (g)
									TPH	TPS	
4	1/8	KPU04-01	12	10.4	44.4	10.4	40.5	17	7.5	7.5	7
	1/4	KPU04-02					42.5				8
6	1/8	KPU06-01	14	12.8	48.6	12.8	44.5	18.5	18	18	9
	1/4	KPU06-02					45.5				10
8	1/8	KPU08-01	17	15.2	55.7	15.2	51.5	20.5	26	26	15
	1/4	KPU08-02					54.5				17
10	1/4	KPU10-02	19	18.5	63.5	18.5	58	23	45	45	23
	3/8	KPU10-03					60.5				25
12	3/8	KPU12-03	22	20.9	68.7	20.9	62.5	24	70	70	29
	1/2	KPU12-04					64.5				30

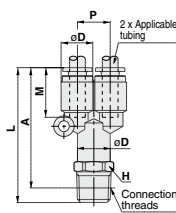

* Reference dimension for R threads after installation Note 1) ϕD indicates the maximum diameter.

Dimensions

Straight Union: KPH



Applicable tubing O.D. (mm)	Model	Note 1) ϕD	L	M	Effective area (mm ²)		Weight (g)
					TPH	TPS	
4	KPH04-00	10.4	35.4	17	4	4	4
6	KPH06-00	12.8	37.6	18.5	10	10	6
8	KPH08-00	15.2	42.4	20.5	26	18	10
10	KPH10-00	18.5	46.6	23	41	29	15
12	KPH12-00	20.9	48.6	24	58	46	18

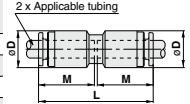

Note 1) ϕD indicates the maximum diameter.

Union Elbow: KPL



Applicable tubing O.D. (mm)	Model	Note 1) ϕD	L	Q	M	Effective area (mm ²)		Weight (g)
						TPH	TPS	
4	KPL04-00	10.4	19.7	4.5	17	3.5	3.5	3
6	KPL06-00	12.8	21.8	5.3	18.5	9	9	7
8	KPL08-00	15.2	25.3	6	20.5	22	15	11
10	KPL10-00	18.5	28.4	6.8	23	35	25	16
12	KPL12-00	20.9	30.4	7.5	24	50	40	20

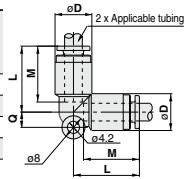

Note 1) ϕD indicates the maximum diameter.

Union Tee: KPT



Applicable tubing O.D. (mm)	Model	Note 1) ϕD	L	Q	M	Effective area (mm ²)		Weight (g)
						TPH	TPS	
4	KPT04-00	10.4	19.7	4.5	17	4	4	7
6	KPT06-00	12.8	21.8	5.3	18.5	10	10	9
8	KPT08-00	15.2	25.3	6	20.5	26	18	16
10	KPT10-00	18.5	28.4	6.8	23	41	29	25
12	KPT12-00	20.9	30.4	7.5	24	58	46	29

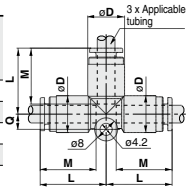

Note 1) ϕD indicates the maximum diameter.

Union "Y": KPU



Applicable tubing O.D. (mm)	Model	Note 1) ϕD	L ₁	L ₂	P	Q	M	Effective area (mm ²)		Weight (g)
								TPH	TPS	
4	KPU04-00	10.4	36.8	19.6	10.4	9.7	17	4	4	7
6	KPU06-00	12.8	40.1	21.8	12.8	11.7	18.5	10	10	10
8	KPU08-00	15.2	46.7	26.5	15.2	13.7	20.5	26	18	17
10	KPU10-00	18.5	52	29.7	18.5	16.1	23	41	29	26
12	KPU12-00	20.9	55.2	31.9	20.9	18.1	24	58	46	32

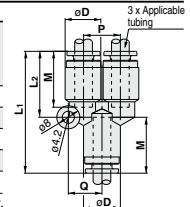

Note 1) ϕD indicates the maximum diameter.

Plug-in Reducer: KPR



Applicable tubing O.D. (mm)	Applicable fitting size ϕd	Model	Note 1) ϕD	L	A	M	Effective area (mm ²)		Weight (g)
							TPH	TPS	
4	6	KPR04-06	10.4	38.4	19.1	17	4	4	3
	8	KPR04-08		40.9	19.2				4
6	10	KPR06-10	12.8	41.5	19.8	18.5	10	10	4
		KPR06-10		44	20.2				5
8	12	KPR08-10	15.2	46	22.2	20.5	26	18	5
		KPR08-12		47					6
10	12	KPR10-12	18.5	49.5	24.7	23	41	29	9

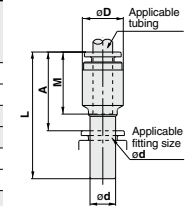

Note 1) ϕD indicates the maximum diameter.

Plug: KPP



Applicable fitting size ϕd	Model	ϕD	L	A	Weight (g)
4	KPP-04	6	32	13.8	0.4
6	KPP-06	8	35	15.7	0.7
8	KPP-08	10	39	17.3	1.1
10	KPP-10	12	43	19.2	1.7
12	KPP-12	14	45.5	20.7	2.5

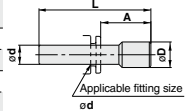

Directional Control Valves

Air Cylinders

Rotary Actuators

Air Grippers

Air Preparation Equipment

Modular F. R.

Pressure Control Equipment

Fittings & Tubing

Flow Control Equipment

Pressure Switches/ Pressure Sensors

Series KPQ/KPG

Clean One-touch Fittings
For Driving Air Piping

RoHS



Series KPQ

Brass (electroless nickel plated)
Release button: Light gray



Series KPG

Stainless steel 304
Release button: Light blue



Made to Order
(Refer to page 1226 for details.)

Particulate Generation Classifications

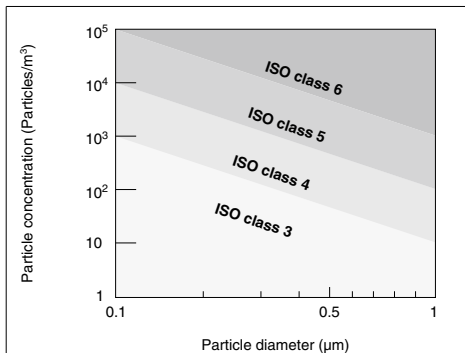

Note) Refer to page 17 for details.

Applicable Tubing

Tube material	PFA, Polyurethane
Tube O.D.	ø4, ø6, ø8, ø10, ø12

FEP, nylon and soft nylon tubing, and tubing not compatible with the clean series can also be used. However, the degree of clean performance will be reduced.

Specifications

Cleanliness class (ISO class)	Class 3 Note 1)
Fluid	Air
Maximum operating pressure (20°C)	1 MPa Note 2)
Operating vacuum pressure	-100 kPa
Proof pressure (20°C)	3 MPa
Ambient and fluid temperature	-5°C to 60°C
Threads	JIS B0203 (Taper thread for piping)
Oil	Fluorine-based grease

Note 1) Refer to particle generation classifications

This falls outside of the grade because fluorine grease is applied to the internal seal materials.

Note 2) The maximum operating pressure is the value at 20°C. Refer to the operating pressure curve for other temperatures.

Note 3) Do not use the fittings with a leak tester or for vacuum retention because they are not guaranteed for zero leakage.

Relation between Operating Temperature and Maximum Operating Pressure

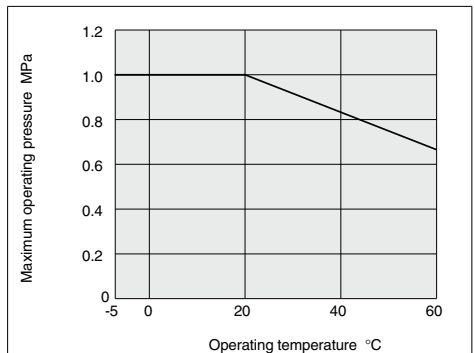

How to Order

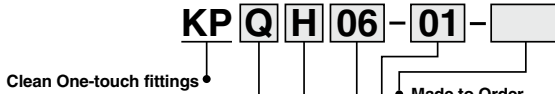

Specifications

Symbol	Specifications (metal part materials)
Q	Brass (electroless nickel plated)
G	Stainless steel 304

Model

H	Male connector, Straight union
L	Union elbow, Male elbow
T	Male branch tee, Union tee
Y	Male run tee
U	Male branch, Union "Y"
R	Plug-in reducer

Applicable tubing O.D.

04	ø4
06	ø6
08	ø8
10	ø10
12	ø12

Made to Order

X53	With sealant tape Grease-free
X193 (Note 1)	Rubber material: EPDM (Fluorine-coated) Gasket: M-SG3 (Stainless steel 316, Special FKM) (Note 2) Release button guide color: Natural

Note 1) Series KPG: Compatible with products with threads only
Note 2) M5 thread

Port size/Applicable tubing O.D.

Thread connection	M5	M5 x 0.8
	01	R1/8
	02	R1/4
	03	R3/8
	04	R1/2
Tubing (rod) connection	00	Same dia. tubing
	04	ø4
	06	ø6
	08	ø8
	10	ø10
	12	ø12

Different dia. tubing (plug-in reducer)



Applicable fitting size

04	ø4
06	ø6
08	ø8
10	ø10
12	ø12

Plug
Clean One-touch fittings

Construction

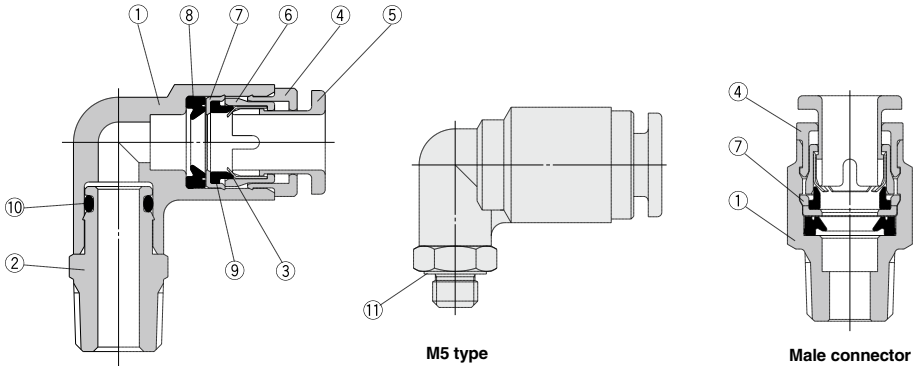

Component Parts

No.	Description	Material	
		Series KPQ	Series KPG
1	Body With male connector	C3604 (Electroless nickel plated)	Stainless steel 304
2	Stud	C3604 (Electroless nickel plated)	Stainless steel 304
3	Chuck	Stainless steel 304	
4	Guide With male connector	C3604 (Electroless nickel plated)	Stainless steel 304
5	Release button	PP (Color: Light gray)	PP (Color: Light blue)
6	Collet	PP	
7	Stopper With male connector	Stainless steel 304	
8	Seal	NBR	
9	Bumper	NBR	
10	O-ring	NBR	
11	Gasket	Stainless steel 304, NBR	

Directional Control Valves
Air Cylinders
Rotary Actuators
Air Grippers
Air Preparation Equipment
Modular F. R.
Pressure Control Equipment
Fittings & Tubing
Flow Control Equipment
Pressure Switches/Pressure Sensors

Dimensions

Male Connector: KPQH, KPGH

(M5)	Applicable tubing O.D. (mm)	Connection thread R M	Model		H (width across flats)	øD	L	A*	M	Effective area (mm ²)		Weight (g)	(M5)				
										TPH	TPS						
(R)	M5 x 0.8	4	KPQH04-M5	—	8	10	24.4	21.5	17	4	4	4					
				KPGH04-M5										—	24.9		
			1/8 KPQH04-01	KPGH04-01	10	—	23.5	18.5						7			
			1/4 KPQH04-02	KPGH04-02	14	—	21.4	16						12			
			1/8 KPQH06-M5	—	8	12	25.3	22						18.5	10	10	5
			KPGH06-M5	—													
	1/8 KPQH06-01	KPGH06-01	12	—	23.7	18.5	7										
	1/4 KPQH06-02	KPGH06-02	14	—	24.6	19	14										
	1/8 KPQH08-01	KPGH08-01	14	—	30.7	25.5	20.5	26	18	14							
	1/4 KPQH08-02	KPGH08-02									—	29.1					
	1/4 KPQH10-02	KPGH10-02	—	—	30.7	30.5					23	41		29	24		
	3/8 KPQH10-03	KPGH10-03	—	—	30.9	25.5					23	41		29	23		
3/8 KPQH12-03	KPGH12-03	19	—	32	26.5	24					58	46	23				
1/2 KPQH12-04	KPGH12-04	22	—	32.2	25	24					58	46	46				

* Reference dimension for R threads after installation

Male Elbow: KPQL, KPGL

(M5)	Applicable tubing O.D. (mm)	Connection thread R M	Model		H (width across flats)	Note 1)		L ₁	L ₂	A*	M	Effective area (mm ²)		Weight (g)	(M5)
						øD1	øD2					TPH	TPS		
(R)	M5 x 0.8	4	KPQL04-M5	KPGL04-M5	8	10.4	8	19.7	15.3	17	17	4	4	4	
				KPQL04-01					KPGL04-01	10					
			1/4 KPQL04-02	KPGL04-02	14				25.5	25					
	1/8 KPQL06-M5	KPGL06-M5	8	15.8	18.5	18.5	10	10	12						
	1/4 KPQL06-01	KPGL06-01	10	12.8	10					21.8	22.3	23.5			
	1/4 KPQL06-02	KPGL06-02	14	—	26.7					27.5	20				
8	1/8	1/4	KPQL08-01	KPGL08-01	12	15.2	12	25.3	23.5	26	20.5	26	18	13	
				KPGL08-02					14	27.9					30
			1/4 KPQL08-02	KPGL08-02	14				—	29.4					33
10	1/4	3/8	KPQL10-02	KPGL10-02	17	18.5	17	28.4	30.8	34.5	23	41	29	26	
				KPGL10-03					17	32					37
			3/8 KPQL12-03	KPGL12-03	19				—	32					37
12	3/8	1/2	KPQL12-04	KPGL12-04	22	20.9	17	30.4	36.2	39.5	24	58	46	65	
				1/2 KPQL12-04					KPGL12-04	22					—

* Reference dimension for R threads after installation Note 1) øD1 indicates the maximum diameter.

Union Tee: KPQT, KPGT

(M5)	Applicable tubing O.D. (mm)	Connection thread R M	Model		H (width across flats)	Note 1)		L ₁	L ₂	A*	M	Effective area (mm ²)		Weight (g)	(M5)
						øD1	øD2					TPH	TPS		
(R)	M5 x 0.8	4	KPQT04-M5	KPGT04-M5	8	10.4	8	19.7	15.3	17	17	4	4	6	
				KPQT04-01					KPGT04-01	10					
			1/4 KPQT04-02	KPGT04-02	14				25.5	25					
	1/8 KPQT06-M5	KPGT06-M5	8	15.8	18.5	18.5	10	10	14						
	1/4 KPQT06-01	KPGT06-01	10	12.8	10					21.8	22.3	23.5			
	1/4 KPQT06-02	KPGT06-02	14	—	26.7					27.5	20				
8	1/8	1/4	KPQT08-01	KPGT08-01	12	15.2	12	25.3	23.5	26	20.5	26	18	14	
				KPQT08-02					14	27.9					30
			1/4 KPQT08-02	KPGT08-02	14				—	29.4					33
10	1/4	3/8	KPQT10-02	KPGT10-02	17	18.5	17	28.4	30.8	34.5	23	41	29	29	
				KPQT10-03					KPGT10-03	17					32
			3/8 KPQT12-03	KPGT12-03	19				—	32					37
12	3/8	1/2	KPQT12-04	KPGT12-04	22	20.9	17	30.4	36.2	39.5	24	58	46	38	
				1/2 KPQT12-04					KPGT12-04	22					—

* Reference dimension for R threads after installation Note 1) øD1 indicates the maximum diameter.

Dimensions

Male Run Tee: KPQY, KPGY

(M5)



(R)



Applicable tubing O.D. (mm)	Connection thread R M	Model		H (width across flats)	Note 1) ϕD_1	ϕD_2	L ₁	L ₂	A*	M	Effective area (mm ²)		Weight (g)		
		KPQY04-M5	KPGY04-M5								TPH	TPS			
4	M5 x 0.8	KPQY04-M5	KPGY04-M5	8	10.4	8	19.7	15.3	31.5	17	4	4	6		
	1/8	KPQY04-01	KPGY04-01	10									21.1	35.5	13
	1/4	KPQY04-02	KPGY04-02	14									25.5	39.5	19
6	M5 x 0.8	KPQY06-M5	KPGY06-M5	8	10	8	21.8	15.8	34	18.5	10	10	7		
	1/8	KPQY06-01	KPGY06-01	10									22.3	39	14
	1/4	KPQY06-02	KPGY06-02	14									26.7	43	20
8	1/8	KPQY08-01	KPGY08-01	12	15.2	12	25.3	23.5	43.5	20.5	26	18	14		
	1/4	KPQY08-02	KPGY08-02	14									27.9	47.5	22
	3/8	KPQY10-03	KPGY10-03	17									29.4	52.5	29
10	1/4	KPQY10-02	KPGY10-02	12	17	17	28.4	30.8	54	23	41	29	39		
	3/8	KPQY12-03	KPGY12-03	17									32	57	41
	1/2	KPQY12-04	KPGY12-04	22									36.2	59.5	68

* Reference dimension for R threads after installation Note 1) ϕD_1 indicates the maximum diameter.

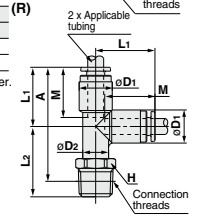
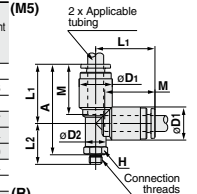

Male Branch: KPQU, KPGU

(M5)



(R)



Applicable tubing O.D. (mm)	Connection thread R M	Model		H (width across flats)	Note 1) ϕD	L	P	A*	M	Effective area (mm ²)		Weight (g)		
		KPQU04-M5	KPGU04-M5							TPH	TPS			
4	M5 x 0.8	KPQU04-M5	KPGU04-M5	11	10.4	40.7	10.4	37	17	4	4	10		
	1/8	KPQU04-01	KPGU04-01	14								42.3	41	11
	1/4	KPQU04-02	KPGU04-02	14								46.7		20
6	M5 x 0.8	KPQU06-M5	KPGU06-M5	13	12.8	43.9	12.8	40.5	18.5	10	10	11		
	1/8	KPQU06-01	KPGU06-01	14								45.5	44.5	21
	1/4	KPQU06-02	KPGU06-02	14								49.9		21
8	1/8	KPQU08-01	KPGU08-01	17	15.2	53.6	15.2	48.5	20.5	26	18	15		
	1/4	KPQU08-02	KPGU08-02	17								59.1	44.5	23
	3/8	KPQU10-03	KPGU10-03	19								62.3	57	30
10	1/4	KPQU10-02	KPGU10-02	19	18.5	59.2	18.5	54	23	41	29	40		
	3/8	KPQU12-03	KPGU12-03	22								64.9	59.5	46
	1/2	KPQU12-04	KPGU12-04	22								69.5	62.5	65

* Reference dimension for R threads after installation Note 1) ϕD indicates the maximum diameter.

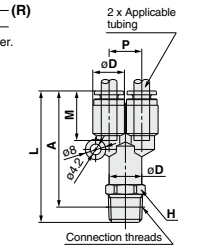
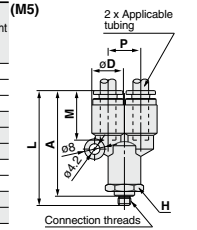

Straight Union: KPQH, KPGH



Applicable tubing O.D. (mm)	Model		Note 1) ϕD	L	M	Effective area (mm ²)		Weight (g)
	KPQH04-00	KPGH04-00				TPH	TPS	
4	KPQH04-00	KPGH04-00	10.4	35.4	17	4	4	4
6	KPQH06-00	KPGH06-00	12.8	37.6	18.5	10	10	6
8	KPQH08-00	KPGH08-00	15.2	42.4	20.5	26	18	10
10	KPQH10-00	KPGH10-00	18.5	46.6	23	41	29	15
12	KPQH12-00	KPGH12-00	20.9	48.6	24	58	46	18

Note 1) ϕD indicates the maximum diameter.

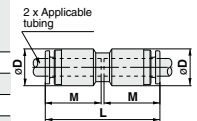

Directional Control Valves

Air Cylinders

Rotary Actuators

Air Grippers

Air Preparation Equipment

Modular F. R.

Pressure Control Equipment

Fittings & Tubing

Flow Control Equipment

Pressure Switches/ Pressure Sensors

Dimensions

Union Elbow: KPQL, KPGL



Applicable tubing O.D. (mm)	Model		Note 1) ϕD		L	Q	M	Effective area (mm ²)		Weight (g)
			ϕD	L				TPH	TPS	
4	KPQL04-00	KPGL04-00	10.4	19.7	4.5	17	3.5	3.5	3	
6	KPQL06-00	KPGL06-00	12.8	21.8	5.3	18.5	9	9	7	
8	KPQL08-00	KPGL08-00	15.2	25.3	6	20.5	22	15	11	
10	KPQL10-00	KPGL10-00	18.5	28.4	6.8	23	35	25	16	
12	KPQL12-00	KPGL12-00	20.9	30.4	7.5	24	50	40	20	

Note 1) ϕD indicates the maximum diameter.

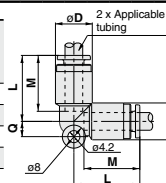

Union Tee: KPQT, KPGT



Applicable tubing O.D. (mm)	Model		Note 1) ϕD		L	Q	M	Effective area (mm ²)		Weight (g)
			ϕD	L				TPH	TPS	
4	KPQT04-00	KPGT04-00	10.4	19.7	4.5	17	4	4	7	
6	KPQT06-00	KPGT06-00	12.8	21.8	5.3	18.5	10	10	9	
8	KPQT08-00	KPGT08-00	15.2	25.3	6	20.5	26	18	16	
10	KPQT10-00	KPGT10-00	18.5	28.4	6.8	23	41	29	25	
12	KPQT12-00	KPGT12-00	20.9	30.4	7.5	24	58	46	29	

Note 1) ϕD indicates the maximum diameter.

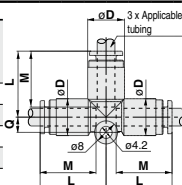

Union "Y": KPQU, KPGU



Applicable tubing O.D. (mm)	Model		Note 1) ϕD		L ₁	L ₂	P	Q	M	Effective area (mm ²)		Weight (g)
			ϕD	L ₁						TPH	TPS	
4	KPQU04-00	KPGU04-00	10.4	36.8	19.6	10.4	9.7	17	4	4	7	
6	KPQU06-00	KPGU06-00	12.8	40.1	21.8	12.8	11.7	18.5	10	10	10	
8	KPQU08-00	KPGU08-00	15.2	46.7	26.5	15.2	13.7	20.5	26	18	17	
10	KPQU10-00	KPGU10-00	18.5	52	29.7	18.5	16.1	23	41	29	26	
12	KPQU12-00	KPGU12-00	20.9	55.2	31.9	20.9	18.1	24	58	46	32	

Note 1) ϕD indicates the maximum diameter.

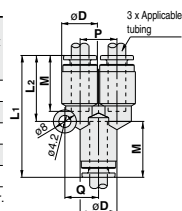

Plug-in Reducer: KPQR, KPGR



Applicable tubing O.D. (mm)	Applicable fitting size ϕd	Model		Note 1) ϕD		L	A	M	Effective area (mm ²)		Weight (g)
				ϕD	L				TPH	TPS	
4	6	KPQR04-06	KPGR04-06	10.4	38.4	19.1	17	4	4	3	
						19.2					
6	8	KPQR06-08	KPGR06-08	12.8	41.5	19.8	18.5	10	10	4	
						20.2					
8	10	KPQR08-10	KPGR08-10	15.2	44	22.2	20.5	26	18	5	
						24.7					
10	12	KPQR10-12	KPGR10-12	18.5	49.5	24.7	23	41	29	9	
						27					

Note 1) ϕD indicates the maximum diameter.

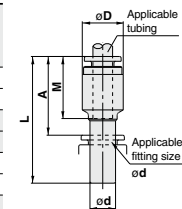

Plug: KPP



Applicable fitting size ϕd	Model	ϕD	L	A	Weight (g)
4	KPP-04	6	32	13.8	0.4
6	KPP-06	8	35	15.7	0.7
8	KPP-08	10	39	17.3	1.1
10	KPP-10	12	43	19.2	1.7
12	KPP-12	14	45.5	20.7	2.5

* The plug is common for series KPQ, KPG and KP.

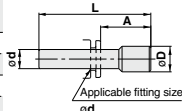



Series KP/KPQ/KPG Specific Product Precautions 1

Be sure to read this before handling.
Refer to page 1382 for Safety Instructions and pages 1237 to 1240 for Fittings and Tubing Precautions.

Selection

⚠ Caution

1. Please consult with SMC regarding fluids other than air, water and nitrogen gas.

Handling

⚠ Caution

1. Store away from direct sunlight at 40°C or less.
2. Open the inner package of double packaging in a clean room or other clean environment.

Installation of Threads

⚠ Caution

Be sure to wind sealant tape around the taper threads for both resin and metal threads.
If used without sealant tape, air leakage can occur.

1. **Series KP (with resin thread)**
 - 1) Winding of sealant tape
Wind the sealant tape 2 to 3 times around the threads, leaving 1.5 to 2 thread ridges exposed at the end of the threads.
 - 2) Tightening
After tightening by hand, tighten an additional 2 to 3 turns using a tightening tool.
2. **Series KPQ/KPG (with metal thread)**
 - 1) For M5
After tightening by hand, tighten approximately 1/6 turn further using a tightening tool. Reference values for the tightening torque are 1 to 1.5 N·m. Excessive tightening can cause air leakage due to thread damage or deformation of the gasket, etc. Insufficient tightening can cause loose threads and air leakage, etc.

Installation of Threads

⚠ Caution

- 2) Taper thread
 - (1) Winding of sealant tape
Wind the sealant tape 2 to 3 times around the threads, leaving 1 thread ridge exposed at the end of the threads.
 - (2) When installing, tighten with the proper torque shown in the table below. As a rule, this corresponds to two or three turns with a tool after tightening by hand.

Connection thread size	Proper tightening torque (N·m)
R1/8	7 to 9
R1/4	12 to 14
R3/8	22 to 24
R1/2	28 to 30

3. Tightening tools

Tighten with an appropriate wrench using the hexagon wrench flats on the body.
Position the wrench on the base as close as possible to the threads. If the size of the wrench is not suitable for the hexagon wrench flats, the wrench flats may be crushed.

Installation and Removal of Tubing

⚠ Caution

1. **Installation of tubing**
 - 1) Grease is not used due to the KP series oil-free specifications. For this reason, greater insertion force is required when tubing is installed. In particular, polyurethane tubing may fold when inserted due to its softness. Hold the end of the tubing, and insert it all the way in slowly and securely. Refer to dimension "M" in the dimension drawings for guidance on the insertion depth of tubing.
2. **Removal of tubing**
 - 1) The outside diameter of tubes that have been used at high temperatures or for long periods of time will expand, and in some cases pipe fittings cannot be reattached. Tubes that cannot be attached should be discarded and replaced with new ones.

Directional
Control Valves

Air Cylinders

Rotary Actuators

Air Grippers

Air Preparation
Equipment

Modular F. R.

Pressure Control
Equipment

Fittings & Tubing

Flow Control
Equipment

Pressure Switches/
Pressure Sensors



Series KP/KPQ/KPG

Specific Product Precautions 2

Be sure to read this before handling.
Refer to page 1382 for Safety Instructions and pages 1237 to 1240 for Fittings and Tubing Precautions.

Operating Environment

Warning

1. Do not use in environments or locations where there is a **danger of damage to fittings and tubing**.
For fitting and tubing materials, refer to specifications and construction drawings, etc.
2. Provide shade in locations which receive direct sunlight.

Caution

1. The KP series are special One-touch fittings for use on **clean blowing and washing lines**.
Please consult with SMC regarding other types of applications.

Seal material: The durability of EPDM with respect to mineral oils is inferior, making it unsuitable for piping in general pneumatic equipment.
Use the KPQ and KPG series for piping to general pneumatic equipment.

Maintenance

Caution

1. **Tightening of blow fittings (resin taper threads for piping)**
Since the KP series taper threads are made of resin, minute leakage may gradually occur due to stress relaxation. Perform periodic inspections, and if leakage is detected correct the problem by further tightening. If additional tightening becomes ineffective, replace the fitting with a new product.
2. **Check for the following during regular maintenance, and replace components as necessary.**
 - a) Scratches, gouges, abrasion, corrosion
 - b) Leakage, refer to item 3 regarding taper thread leakage.
 - c) Twisting, flattening or distortion of tubing
 - d) Hardening, deterioration or softness of tubing
3. **Do not repair or patch the replaced tubing or fittings for reuse.**