

# Aluminum High Vacuum Angle Valve



■ Improved durability of bellows (Flange sizes 100 and 160)

■ Service life of two million cycles\*<sup>1</sup>

\*<sup>1</sup> The service life is based on SMC's testing. Refer to the operation manual for details.

■ Space required for equipment can be reduced

Without restriction on exhaust direction (two ways: from valve element side to bellows side and vice versa)

Increased flexibility of mounting orientation

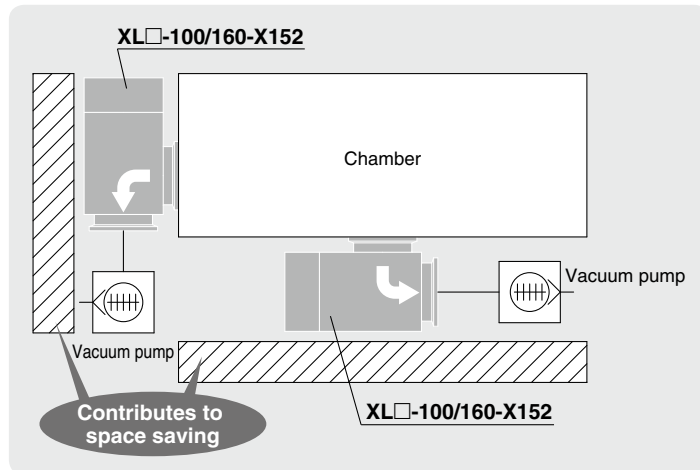

XLA-□-X152

■ Lightweight, Compact

Large conductance, small body, excellent resistance against fluorine corrosion (body)

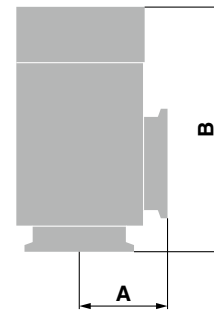

With restriction on exhaust direction (one way only: from valve element side to bellows side)

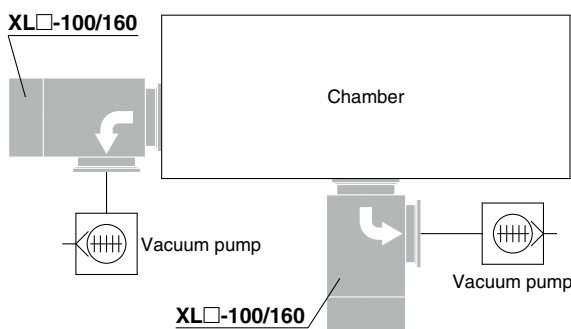

Model	A [mm]	B [mm]	Weight [kg]	Conductance [L/s]
XLA-100-X152	108	300	10.6	300
XLA-160-X152	138	315	18.5	800

## Variations

Model	Valve type	Operating pressure [Pa(abs)]	Leakage [Pa·m <sup>3</sup> /s]		Flange size		Option			
			Internal* <sup>1</sup>	External* <sup>1</sup>	100	160	Switch	Heater	Indicator	High-temperature type
XLA-100/160-X152	Single acting (N.C.)	10 <sup>-6</sup> to atmospheric pressure	10 <sup>-10</sup>	10 <sup>-11</sup>	●	●	●	●	●	●
XLC-100/160-1-X152	Double acting				●	●	●	●		●

\*<sup>1</sup> When the standard seal material (FKM) is used

# XLA/C-100/160(-1)-X152



18-E692

# Aluminum High Vacuum Angle Valve Normally Closed, Bellows Seal

RoHS

# XLA-100/160-X152

## How to Order

XLA - 100       - M9N A -   - X152

①
②
③
④
⑤
⑥
⑦

• Improved durability of bellows

### ① Flange size

Size
100
160

### ② Flange type

Symbol	Type
Nil	KF (NW)
D	K (DN)

### ④ Temperature specifications/Heater

Symbol	Temperature	Heater
Nil	5 to 60°C	—
High-temperature type	H0	—
	H4	5 to 150°C
	H5	With 120°C heater

\* Heater cannot be retrofitted for the H0 type.

\* The type with a heater is currently only available as a special order. Please contact your local sales representative.

### ⑥ Number of auto switches/Mounting position

Symbol	Quantity	Mounting position
Nil	Without auto switch	—
A	2	Valve open/closed
B	1	Valve open
C	1	Valve closed

### ⑦ Body surface treatment/Seal material and changed parts

#### • Body surface treatment

Symbol	Surface treatment
Nil	External: Hard anodized Internal: Raw material
A	External: Hard anodized Internal: Oxalic acid anodized

#### • Seal material

Symbol	Seal material	Compound no.
Nil	FKM	1349-80*1
N1	EPDM	2101-80*1
P1	Barrel Perfluoro®	70W
Q1	Kalrez®	4079
R1	Chemraz®	SS592
R2		SS630
R3		SS638
S1	VMQ	1232-70*1
T1	FKM for Plasma	3310-75*1
U1	ULTIC ARMOR®	UA4640

\*1 Produced by MITSUBISHI CABLE INDUSTRIES, LTD.

Barrel Perfluoro® is a registered trademark of MATSUMURA OIL Co., Ltd.  
Kalrez® is a registered trademark of E. I. du Pont de Nemours and Company or its affiliates.  
Chemraz® is a registered trademark of Greene, Tweed Technologies, Inc.  
ULTIC ARMOR® is a registered trademark of NIPPON VALQUA INDUSTRIES, LTD.

### ③ Indicator/Pilot port direction

Symbol	Indicator	Pilot port direction
Nil	Without indicator	Flange side
A	With indicator	Flange side
F		Left flange surface
G		Rear flange surface
J		Right flange surface
K	Without indicator	Left flange surface
L		Rear flange surface
M		Right flange surface

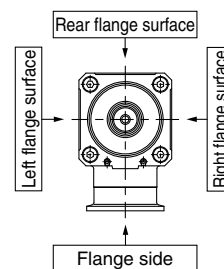

### ⑤ Auto switch type

Symbol	Model	Remarks
Nil	—	Without auto switch (without magnet)
M9N(M)(L)(Z)	D-M9N(M)(L)(Z)	Solid state auto switch
M9P(M)(L)(Z)	D-M9P(M)(L)(Z)	
M9B(M)(L)(Z)	D-M9B(M)(L)(Z)	
A90(L)	D-A90(L)	Reed auto switch
A93(M)(L)(Z)	D-A93(M)(L)(Z)	
M9//	—	Without auto switch (with magnet)

\* Auto switches shown above cannot be mounted on the high-temperature type. For the high-temperature type, a semi-standard product that uses the heat resistant auto switch D-F7NJ is available. For details, please contact SMC.

\* Standard lead wire length is 0.5 m. Add L to the end of the part number for 3 m, M for 1 m, and Z for 5 m.

Example) -M9NL

\* A type with a pre-wired connector is also selectable. Example) -M9NSAPC

\* Refer to the [Auto Switch Catalog](#) for further information on auto switches.

#### • Part with changed seal material and leakage

Symbol	Changed part*2	Leakage [Pa·m <sup>3</sup> /s or less]*1	
		Internal	External
Nil	None	1.3 x 10 <sup>-10</sup> (FKM)	1.3 x 10 <sup>-11</sup> (FKM)
A	②, ③	1.3 x 10 <sup>-8</sup>	1.3 x 10 <sup>-9</sup>
B	②	1.3 x 10 <sup>-8</sup>	1.3 x 10 <sup>-11</sup> (FKM)
C	③	1.3 x 10 <sup>-10</sup> (FKM)	1.3 x 10 <sup>-9</sup>

\*1 Values at normal temperature, excluding gas permeation

\*2 Refer to Construction on page 2 for changed part. Number corresponds with the parts number on the construction drawing.

To order something other than Nil (standard), followed by each symbol for body surface treatment, seal material, and then changed part.

Example) XLA-100-M9NA-AN1A-X152

# Aluminum High Vacuum Angle Valve Normally Closed, Bellows Seal **XLA-100/160-X152**

## Specifications

Model		XLA-100-X152	XLA-160-X152
Valve type		Normally closed (Pressurize to open, Spring seal)	
Fluid		Inert gas under vacuum	
Operating temperature [°C]		5 to 60 (High-temperature type: 5 to 150)	
Operating pressure [Pa(abs)]		1 x 10 <sup>-6</sup> to atmospheric pressure	
Conductance [L/s]*1		300	800
Leakage [Pa·m <sup>3</sup> /s]	Internal	For standard seal material (FKM): 1.3 x 10 <sup>-10</sup> at normal temperature, excluding gas permeation	
	External	For standard seal material (FKM): 1.3 x 10 <sup>-11</sup> at normal temperature, excluding gas permeation	
Flange type		KF (NW), K (DN)	
Principal materials		Body: Aluminum alloy Bellows: Stainless steel Chief part: Stainless steel, FKM (standard seal material)	
Surface treatment		External: Hard anodized Internal: Raw material	
Pilot pressure [MPa(G)]		0.4 to 0.7	
Pilot port size		Rc1/8	Rc1/4
Weight [kg]		10.6	18.5

\*1 Conductance is the value for the elbow with the same dimensions.  
\* For valve heater specifications, refer to Common Option [1] Heater on page 5.

## Construction/Operation

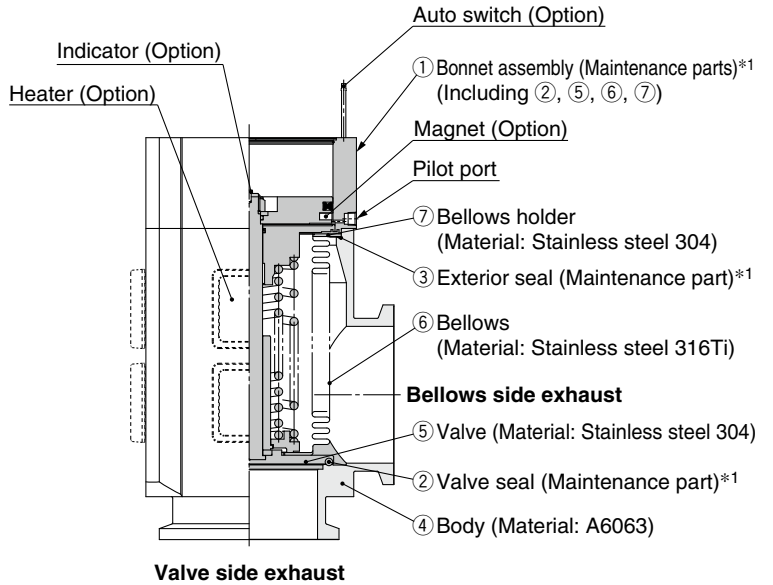

\*1 Refer to Maintenance Parts on page 6.

### <Working principle>

By applying pilot pressure from the pilot port, the piston-coupled valve overcomes the force of the spring or operating force by pressure, and the valve opens.

### <Option>

**Auto switch:** The magnet activates the auto switch. With 2 auto switches, the open and closed positions are detected, and with 1 auto switch, either the open or closed position is detected. The temperature range is only available for general use (5 to 60°C).

**Heater :** Heating is performed simply using thermistors. The valve body can be heated to approximately 100 or 120°C, depending on the size of the valve. The type and number of thermistors to be used will vary depending on the size and setting temperature. For the high-temperature type, the bonnet assembly is a heat-resistant structure. This does not apply in cases where a solenoid valve is attached.

**Indicator :** When the valve is open, an orange marker appears in the center of the name plate.

## Dimensions

### XLA-100/160-X152: Air operated

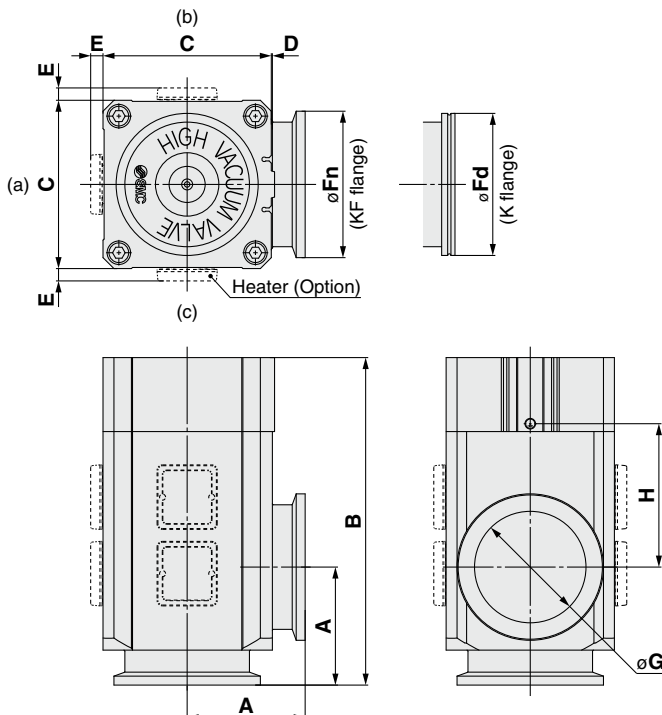

Model	A	B	C	D	E*1	Fn	Fd	G	H
XLA-100-X152	108	300	154	3	11	134	130	102	131
XLA-160-X152	138	315	200	3	11	190	180	153	112

\*1 The E dimension applies when the heater option is included. (Lead wire length: Approx. 1 m)

\* (a), (b), (c) in the above drawing indicate heater mounting positions. Moreover, heater mounting positions will differ depending on the type of heater. For details, refer to Common Option [2] Mounting position of the heater on page 5.

# Aluminum High Vacuum Angle Valve Double Acting, Bellows Seal

RoHS

# XLC-100/160-1-X152

## How to Order

XLC-100   -1M9NA- -X152

1

2

3

4

5

6

7

Improved durability of bellows

### 1 Flange size

Size
100
160

### 2 Flange type

Symbol	Type
Nil	KF (NW)
D	K (DN)

### 4 Temperature specifications/Heater

Symbol	Temperature	Heater
Nil	5 to 60°C	—
High-temperature type	H0	—
	H4	5 to 150°C With 100°C heater
	H5	5 to 150°C With 120°C heater

\* Heater cannot be retrofitted for the H0 type.

\* The type with a heater is currently only available as a special order. Please contact your local sales representative.

### 6 Number of auto switches/Mounting position

Symbol	Quantity	Mounting position
Nil	Without auto switch	—
A	2	Valve open/closed
B	1	Valve open
C	1	Valve closed

### 7 Body surface treatment/Seal material and changed parts

#### Body surface treatment

Symbol	Surface treatment
Nil	External: Hard anodized Internal: Raw material
A	External: Hard anodized Internal: Oxalic acid anodized

#### Seal material

Symbol	Seal material	Compound no.
Nil	FKM	1349-80*1
N1	EPDM	2101-80*1
P1	Barrel Perfluoro®	70W
Q1	Kalrez®	4079
R1	Chemraz®	SS592
R2		SS630
R3		SS638
S1	VMQ	1232-70*1
T1	FKM for Plasma	3310-75*1
U1	ULTIC ARMOR®	UA4640

\*1 Produced by MITSUBISHI CABLE INDUSTRIES, LTD.

Barrel Perfluoro® is a registered trademark of MATSUMURA OIL Co., Ltd.  
Kalrez® is a registered trademark of E. I. du Pont de Nemours and Company or its affiliates.

Chemraz® is a registered trademark of Greene, Tweed Technologies, Inc.  
ULTIC ARMOR® is a registered trademark of NIPPON VALQUA INDUSTRIES, LTD.

### 3 Pilot port direction

Symbol	Pilot port direction
Nil	Flange side
K	Left flange surface
L	Rear flange surface
M	Right flange surface

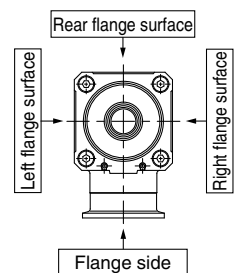

### 5 Auto switch type

Symbol	Model	Remarks
Nil	—	Without auto switch (without magnet)
M9N(M)(L)(Z)	D-M9N(M)(L)(Z)	Solid state auto switch
M9P(M)(L)(Z)	D-M9P(M)(L)(Z)	
M9B(M)(L)(Z)	D-M9B(M)(L)(Z)	
A90(L)	D-A90(L)	Reed auto switch
A93(M)(L)(Z)	D-A93(M)(L)(Z)	
M9//	—	Without auto switch (with magnet)

\* Auto switches shown above cannot be mounted on the high-temperature type. For the high-temperature type, a semi-standard product that uses the heat resistant auto switch D-F7NJ is available. For details, please contact SMC.

\* Standard lead wire length is 0.5 m. Add L to the end of the part number for 3 m, M for 1 m, and Z for 5 m.

Example) -M9NL

\* A type with a pre-wired connector is also selectable. Example) -M9NSAPC

\* Refer to the [Auto Switch Catalog](#) for further information on auto switches.

#### Part with changed seal material and leakage

Symbol	Changed part*2	Leakage [Pa·m³/s or less]*1	
		Internal	External
Nil	None	1.3 x 10 <sup>-10</sup> (FKM)	1.3 x 10 <sup>-11</sup> (FKM)
A	②, ③	1.3 x 10 <sup>-8</sup>	1.3 x 10 <sup>-9</sup>
B	②	1.3 x 10 <sup>-8</sup>	1.3 x 10 <sup>-11</sup> (FKM)
C	③	1.3 x 10 <sup>-10</sup> (FKM)	1.3 x 10 <sup>-9</sup>

\*1 Values at normal temperature, excluding gas permeation

\*2 Refer to Construction on page 4 for changed part. Number corresponds with the parts number on the construction drawing.

To order something other than Nil (standard), followed by each symbol for body surface treatment, seal material, and then changed part.

Example) XLC-100-1M9NA-AN1A-X152

# Aluminum High Vacuum Angle Valve Double Acting, Bellows Seal **XLC-100/160-1-X152**

## Specifications

Model		<b>XLC-100-1-X152</b>	<b>XLC-160-1-X152</b>
Valve type		Double acting (Dual operation), Pressurize to open/close	
Fluid		Inert gas under vacuum	
Operating temperature [°C]		5 to 60 (High-temperature type: 5 to 150)	
Operating pressure [Pa(abs)]		1 x 10 <sup>-6</sup> to atmospheric pressure	
Conductance [L/s]*1		300	800
Leakage [Pa·m <sup>3</sup> /s]	Internal	For standard seal material (FKM): 1.3 x 10 <sup>-10</sup> at normal temperature, excluding gas permeation	
	External	For standard seal material (FKM): 1.3 x 10 <sup>-11</sup> at normal temperature, excluding gas permeation	
Flange type		KF (NW), K (DN)	
Principal materials		Body: Aluminum alloy Bellows: Stainless steel Chief part: Stainless steel, FKM (standard seal material)	
Surface treatment		External: Hard anodized Internal: Raw material	
Pilot pressure [MPa(G)]		0.4 to 0.6	
Pilot port size		Rc1/8	Rc1/4
Weight [kg]		8.7	14.5

\*1 Conductance is the value for the elbow with the same dimensions.  
\* For valve heater specifications, refer to Common Option [1] Heater on page 5.

## Construction/Operation

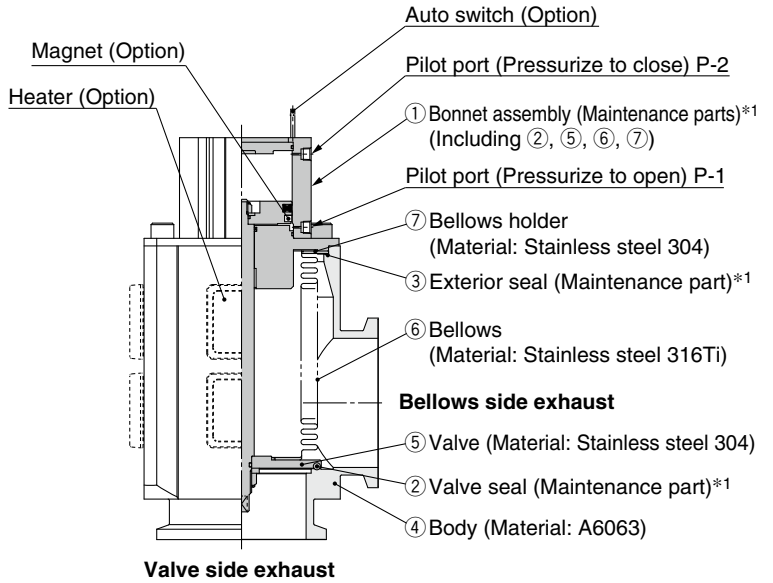

\*1 Refer to Maintenance Parts on page 6.

### <Working principle>

By applying pilot pressure from the pilot port P-1, the piston-coupled valve overcomes the operating force by the pressure, and the valve opens. (Pilot port P-2 is open.) Alternatively, by applying pilot pressure to pilot port P-2, the valve closes. (Pilot port P-1 is open.)

### <Option>

- Auto switch:** The magnet activates the auto switch. With 2 auto switches, the open and closed positions are detected, and with 1 auto switch, either the open or closed position is detected. The temperature range is only available for general use (5 to 60°C).
- Heater:** Heating is performed simply using thermistors. The valve body can be heated to approximately 100 or 120°C, depending on the size of the valve. The type and number of thermistors to be used will vary depending on the size and setting temperature. For the high-temperature type, the bonnet assembly is a heat-resistant structure. This does not apply in cases where a solenoid valve is attached.
- Indicator:** When the valve is open, an orange marker appears in the center of the name plate.

## Dimensions

### XLC-100/160-1-X152: Air operated

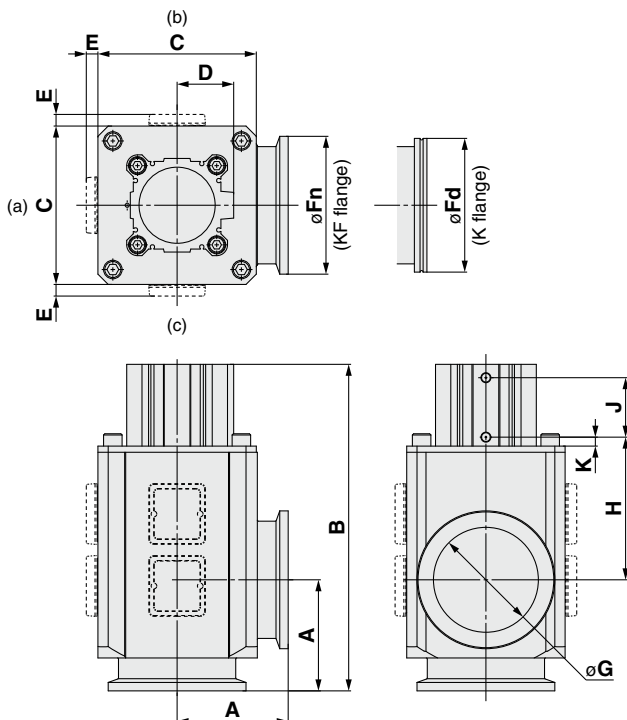

Model	A	B	C	D	E*1	Fn	Fd	G	H	J	K
<b>XLC-100-1-X152</b>	108	317.5	154	55	11	134	130	102	139	58	9
<b>XLC-160-1-X152</b>	138	339	200	65	11	190	180	153	124	62	12.5

\*1 The E dimension applies when the heater option is included. (Lead wire length: Approx. 1 m)

\* (a), (b), (c) in the above drawing indicate heater mounting positions.

Moreover, heater mounting positions will differ depending on the type of heater.

For details, refer to Common Option [2] Mounting position of the heater on page 5.

# XL□-100/160(-1)-X152 Common Option

## 1 Heater

Valve heaters are common for models **XLA** and **XLC**. Power consumption specifications are shown below.

Model		XL□-100(-1)-X152	XL□-160(-1)-X152	
Rated voltage for heater		90 to 240 VAC		
Heater assembly quantity used Heater power W (Nominal value) Inrush/Power consumption (Option symbol, Operating voltage)	Heater assembly quantity	2	3	
	<b>H4</b> 100°C	100 V	800/220	1200/350
		200 V	3200/220	4800/350
	Heater assembly quantity		3	4
	<b>H5</b> 120°C	100 V	1200/300	1600/400
		200 V	4800/300	6400/400

- \* The inrush current of the heater flows for several tens of seconds when using 100 V, while it flows for several seconds when using 200 V. However, this inrush current will decrease shortly after.
- \* When the valve uses multiple heater assemblies, do not turn on the power to each heater assembly at the same time. Turn on the power to each heater assembly one-by-one at intervals of 30 sec. since the inrush current is large.
- \* The heater temperature will decrease several % from the start of heating and then becomes stable. (The heater temperature may decrease approximately 5 to 10% due to individual differences.)
- \* Refer to Maintenance Parts on page 6 for further details regarding quantity and type.

### Inrush Current Flow Time (Reference)

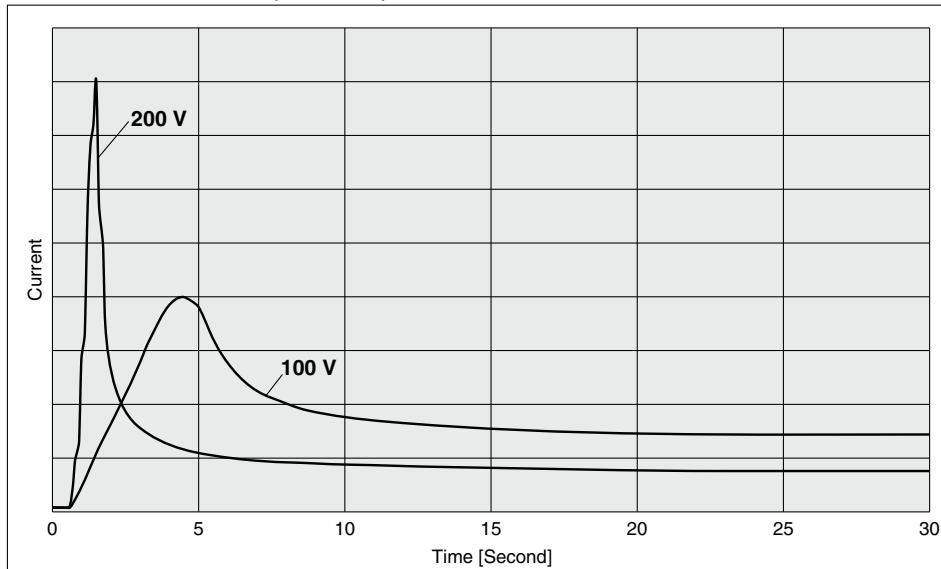

## 2 Mounting Position of the Heater

Heater symbol	XL□-100(-1)-X152	XL□-160(-1)-X152
<b>H4</b> (100°C)	(b), (c)	(a), (b), (c)
<b>H5</b> (120°C)	(a), (b), (c)	(b), (c)

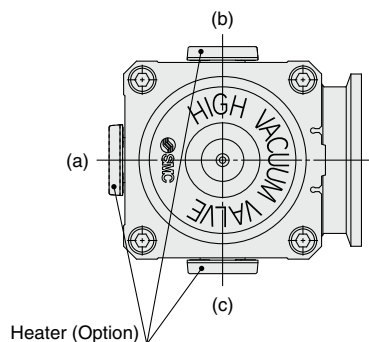



# XL□-100/160(-1)-X152 Specific Product Precautions

Be sure to read this before handling the products.

## Maintenance Parts

### Air operated angle valve



### Caution

1. Replace the bonnet assembly when changing the seal material.  
It may not be applicable when a seal material different from the current one has been chosen.

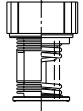

Bonnet assembly

### Bonnet Assembly

Model	Temperature specification	Indicator	Valve size	
			100	160
XLA-X152	General use	None	XLA100-30-1-X152	XLA160-30-1-X152
		Yes	XLA100A-30-1-X152	XLA160A-30-1-X152
	High-temperature	None	XLA100-30-1H-X152	XLA160-30-1H-X152
		Yes	XLA100A-30-1H-X152	XLA160A-30-1H-X152
XLC-1-X152	General use	None	XLC100-30-1-1-X152	XLC160-30-1-1-X152
	High-temperature	None	XLC100-30-1H-1-X152	XLC160-30-1H-1-X152

\* In cases where the material of the valve seal is anything other than the standard (FKM: Compound no. 1349-80: made by MITSUBISHI CABLE INDUSTRIES, LTD.), add the symbol for the seal material (see Table 1) to the part number.

\* An auto switch magnet is not installed. In cases where an auto switch magnet is installed, add -M9// to the part number. (Not available for the high-temperature type)

\* An auto switch is not attached. When a product with an auto switch is required, add the symbol for the auto switch to the part number.

Example) In cases where the material of the valve seal is changed: XLA100-30-1-N1-X152

### Exterior Seal/Valve Seal

Model	Description (Construction no.)	Material	Valve size	
			100	160
XLA-X152 XLC-1-X152	Exterior seal ③	Standard	AS568-050V	AS568-167V
		Special	AS568-050□	AS568-167□
	Valve seal ②	Standard	AS568-349V	B2401-G155V
		Special	AS568-349□	B2401-G155□

\* In cases where the seal material is anything other than the standard (FKM: Compound no. 1349-80: made by MITSUBISHI CABLE INDUSTRIES, LTD.), add the symbol for the seal material (see Table 1) to the end of the part number (in place of □).

\* Refer to the Construction section of each series for component part numbers.

Table 1: Symbol for Seal Material

Symbol	-XN1	-XP1	-XQ1	-XR1	-XR2	-XR3	-XS1	-XT1	-XU1
Seal material	EPDM	Barrel Perfluoro®	Kalrez®	Chemraz®			VMQ	FKM for Plasma	ULTIC ARMOR®
Compound no.	2101-80*1	70W	4079	SS592	SS630	SSE38	1232-70*1	3310-75*1	UA4640

\* It may not be applicable when a seal material different from the current one has been chosen.

\*1 Produced by MITSUBISHI CABLE INDUSTRIES, LTD.

Barrel Perfluoro® is a registered trademark of MATSUMURA OIL Co., Ltd.

Kalrez® is a registered trademark of E. I. du Pont de Nemours and Company or its affiliates.

Chemraz® is a registered trademark of Greene, Tweed Technologies, Inc.

ULTIC ARMOR® is a registered trademark of NIPPON VALQUA INDUSTRIES, LTD.

### Replacement Heaters

Temperature specification	Valve size	
	100	160
H4 (100°C heater)	XL1A25-60S-2 (2 sets)	XL1A25-60S-2 (3 sets)
H5 (120°C heater)	XL1A25-60S-2 (3 sets)	XL1A25-60S-2 (4 sets)

Example) For the XL□-100H5-X152 with a heater, 3 sets of the XL1A25-60S-2 are required.

\* The type with a heater (maintenance part) is currently only available as a special order.  
Please contact your local sales representative.

 **Safety Instructions** Be sure to read the "Handling Precautions for SMC Products" (M-E03-3) and "Operation Manual" before use.