

Deceleration Controller

New

RoHS

2-speed control reduces cycle time

Allows for the impact relaxation of the stroke end

Allows for the 2-speed control of cylinders

The deceleration position (cushion timing) and 2nd speed (cushion intensity) can be adjusted.

Possible to control flow rate values using an adjustment handle with graduations

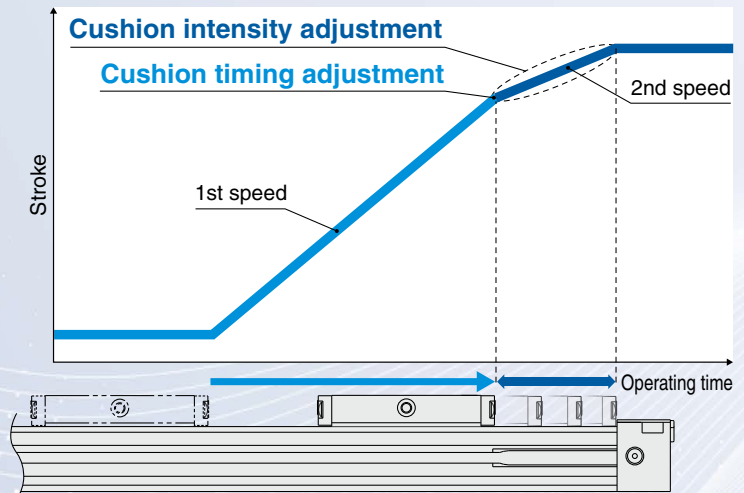

Reduction of work-hours

Reduction of incorrect setting

Adjustment handle with graduations
Deceleration position adjustment (Light blue) (Timing knob)
2nd speed adjustment (Gray) (2nd speed knob)

For single-end (Left side)

For single-end (Right side)

For double-end (Unit)



Space saving Maximum 76% reduction of occupying space 196 cm³ ← 811 cm³

• Example of a circuit when performing two-speed control using DAS

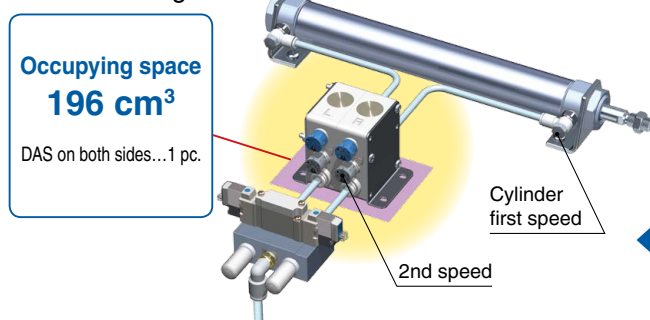

• Example of a circuit when performing two-speed control without using DAS

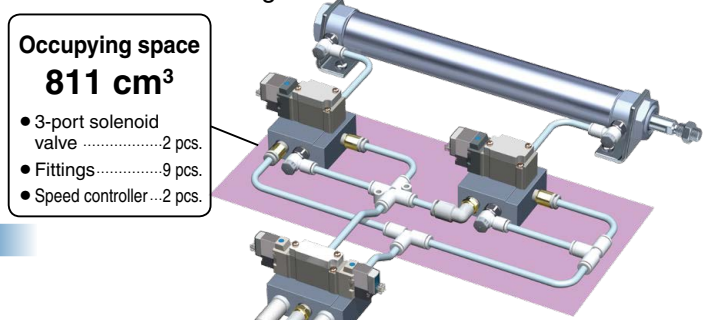

DAS Series



CAT.ES20-290A

Piping Example

For double-end

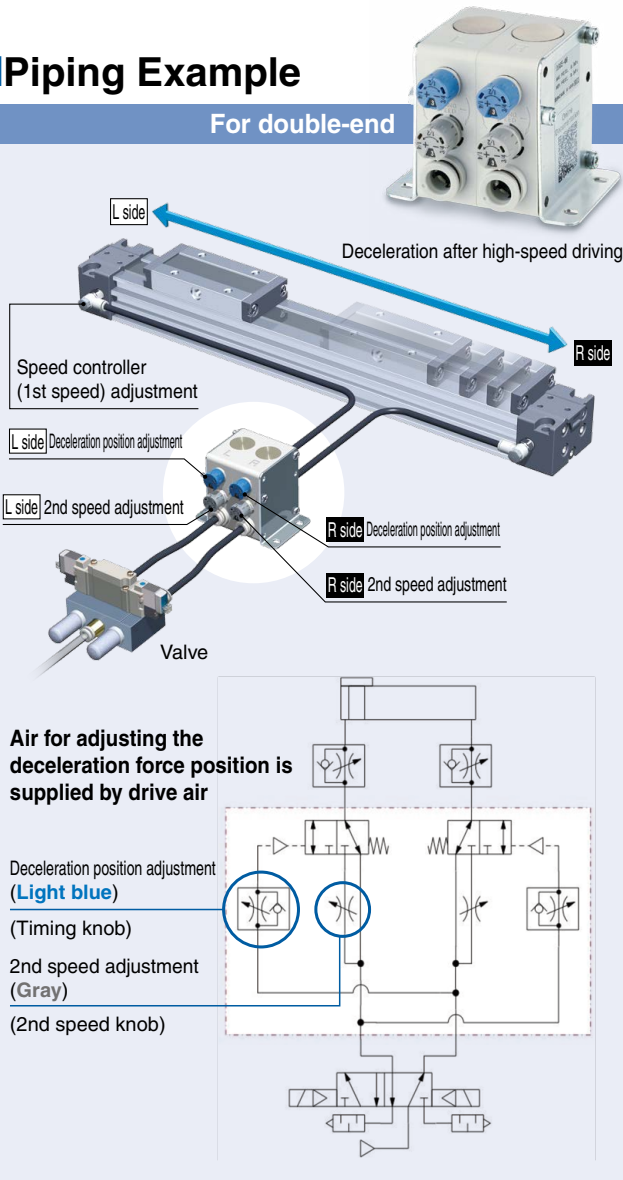

For single-end

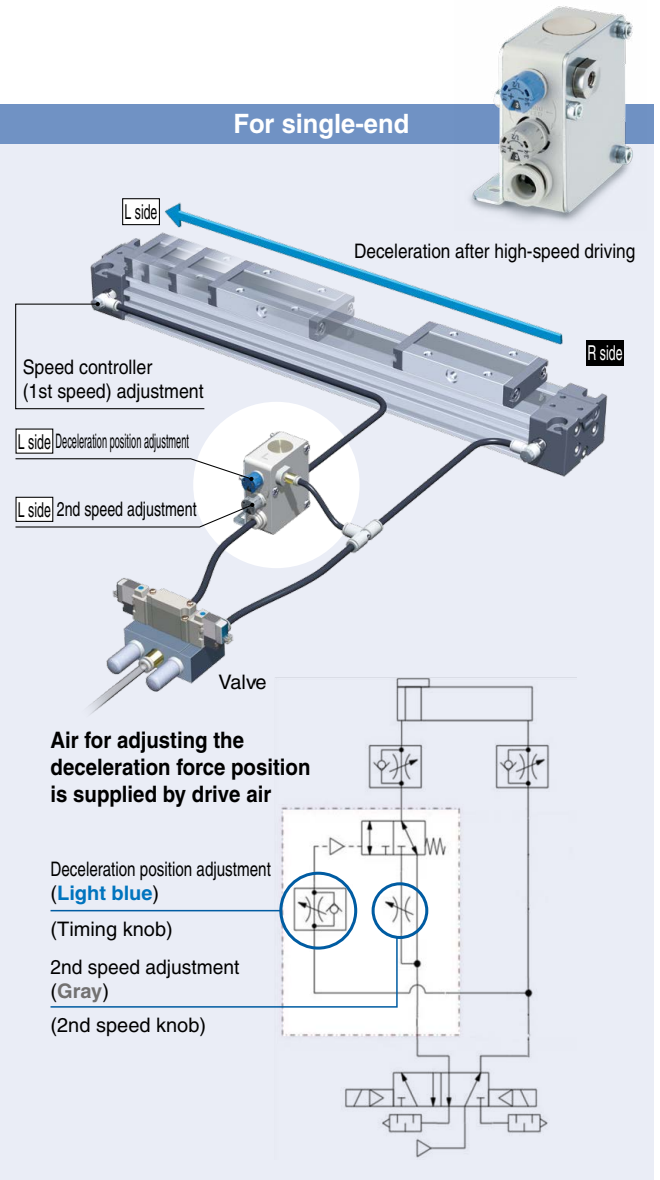



- Provides impact relaxation in cases where it is difficult to install a shock absorber, etc.
- No fluctuation effect on the supply pressure
- Can be easily introduced to existing equipment due to installation between the valve and cylinder

Application Example

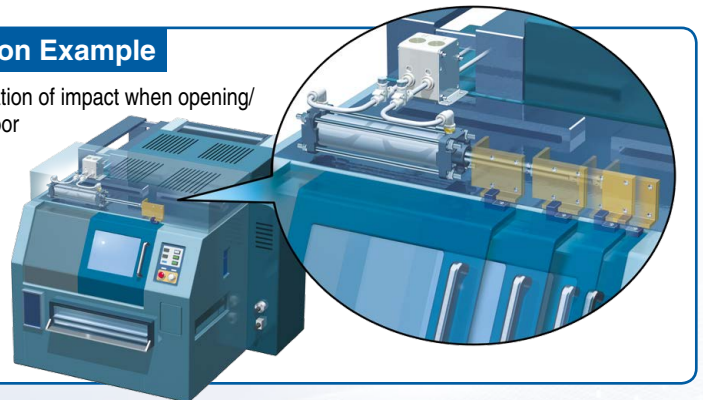
For the relaxation of impact when opening/closing the door



Variations

Mounting	Body size	Applicable tubing O.D.										Bore size
		Metric size					Inch size					
		4	6	8	10	12	5/32"	1/4"	5/16"	3/8"	1/2"	
Double-end 	5	●	●	●			●	●	●			ø10 to ø40
	7			●	●	●				●	●	
Left side Right side 	5	●	●	●			●	●	●			ø10 to ø40
	7			●	●	●			●	●	●	Up to ø100

Deceleration Controller

DAS Series



Model

Model	Applicable tubing O.D.									
	Metric size					Inch size				
	ø4	ø6	ø8	ø10	ø12	ø5/32"	ø1/4"	ø5/16"	ø3/8"	ø1/2"
DAS5-□	●	●	●			●	●	●		
DAS7-□			●	●	●			●	●	●

Specifications

Fluid	Air
Proof pressure	1.05 MPa
Max. operating pressure	0.7 MPa
Min. operating pressure	0.2 MPa
Ambient and fluid temperatures	-5 to 60°C (No freezing)
Applicable tubing material	Nylon, Soft nylon, Polyurethane, FEP, PFA

* Pay attention to the maximum operating pressure for applicable tube materials, soft nylon, and polyurethane. Refer to the **Web Catalog** for details.

Target Cylinder Area

Model	Applicable cylinder range	
	Bore size	Stroke
DAS5-□	ø10 to ø40	50 mm or more
DAS7-□	Up to ø100	

Flow Rate Characteristics

Model	Bore size		Flow rate characteristics			
	Metric	Inch	C values: Sonic conductance dm ³ /(s·bar)		b values: Critical pressure ratio	
			Before deceleration	After deceleration	Before deceleration	After deceleration
DAS5-□	ø4	ø5/32"	0.6	0.2	0.4	0.6
	ø6	ø1/4"	1.5		0.4	
	ø8	ø5/16"	2.3		0.3	
DAS7-□	ø8	ø5/16"	3.1	0.6	0.4	0.3
	ø10	ø3/8"	4.3		0.3	
	ø12	—	5.1		0.2	
	—	ø1/2"	5.1		0.2	

How to Order

DAS 5 □ - 06

Body size

Symbol
5
7

Applicable tubing O.D.

Metric size		Inch size	
04	ø4	03	ø5/32"
06	ø6	07	ø1/4"
08	ø8	09	ø5/16"
10	ø10	11	ø3/8"
12	ø12	13	ø1/2"

Mounting

Symbol	Mounting		
Nil	Mounting on both sides		
L	Mounting on one side (Left side)		
R	Mounting on one side (Right side)		

* For selecting applicable tubing O.D., refer to the "Model".

Metric size and inch size types can be visually identified by color of the release button.

Metric size: Light gray
Inch size: Orange

DAS Series

Construction

DAS5

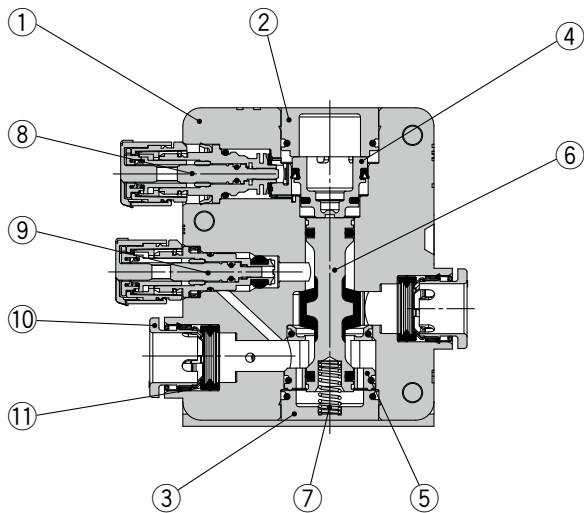

Component Parts

No.	Description	Material	Note
1	Body	PBT	
2	Cover A	Brass	Electroless nickel plating
3	Cover B	Brass	Electroless nickel plating
4	Piston	POM	
5	Retainer	POM	
6	Spool	—	Rubber lined
7	Spring	Steel wire	
8	Body assembly (Timer)	—	
9	Body assembly (Cushion)	—	
10	Cassette	—	
11	Seal	NBR	

DAS7

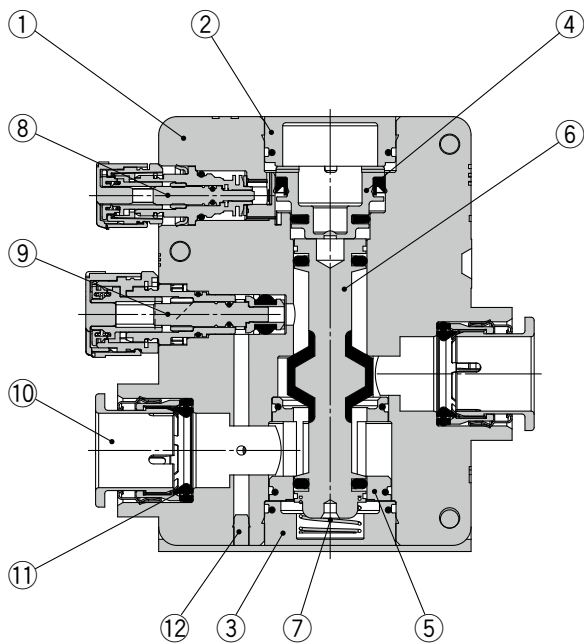

Component Parts

No.	Description	Material	Note
1	Body	PBT	
2	Cover A	Brass	Electroless nickel plating
3	Cover B	Brass	Electroless nickel plating
4	Piston	POM	
5	Retainer	POM	
6	Spool	—	Rubber lined
7	Spring	Steel wire	
8	Body assembly (Timer)	—	
9	Body assembly (Cushion)	—	
10	Cassette	—	
11	Seal	NBR	
12	Plug	Brass	Electroless nickel plating

Dimensions/Metric Size

Mounting on one side (Left side)

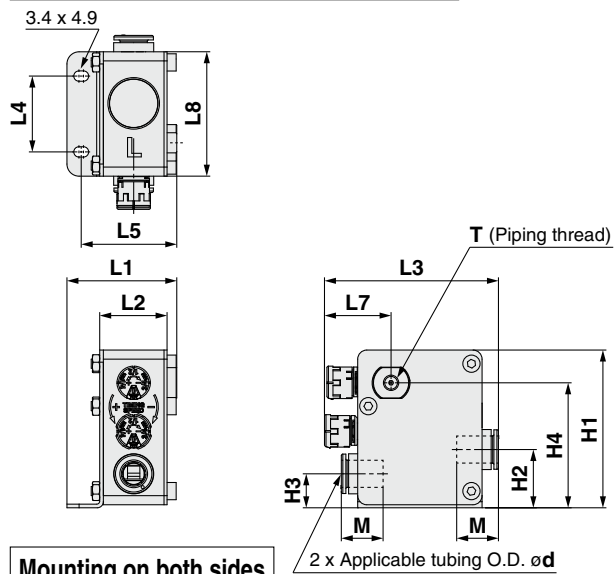

Mounting on one side (Right side)

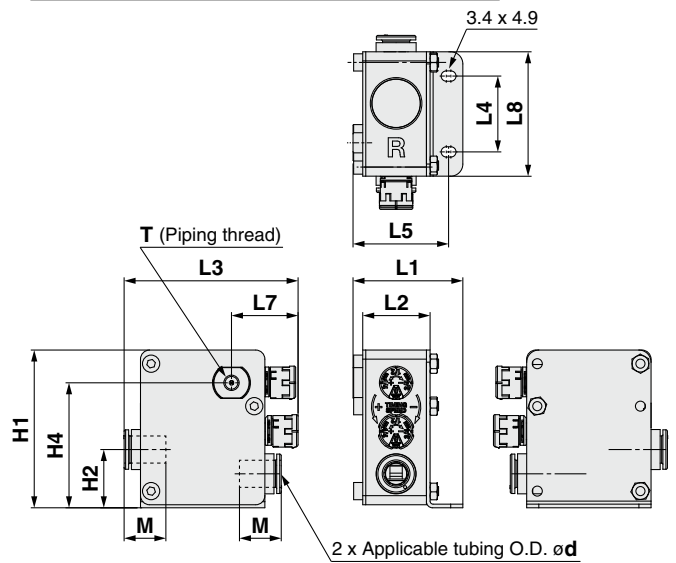

Mounting on both sides

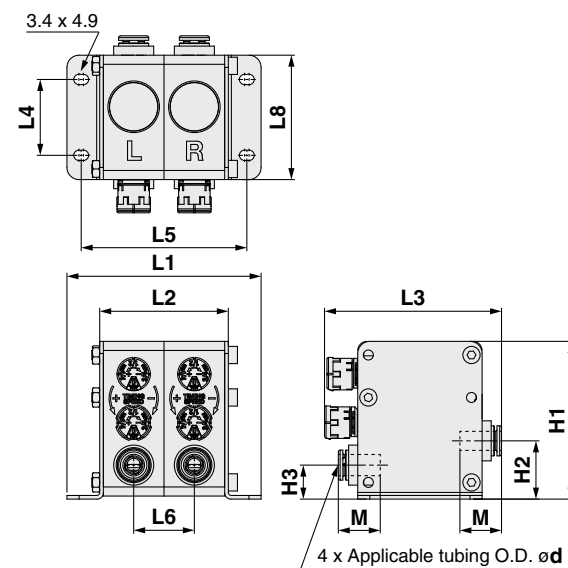

Model	d	H1	H2	H3	H4	L1	L2	L3		L4	L5	L6	L7	L8	T	M	Weight [g]
								Unlocked	Locked								
DAS5-04	ø4	52	19.2	11.2	—	64	42.4	59.3	58.2	25	54.6	20	—	41	—	12.9	151
DAS5-06	ø6							59.5	58.4							13.8	142
DAS5-08	ø8							58.5	57.4							14.2	134
DAS5L-04	ø4	52	19.2	11.2	41.2	36.2	22.2	59.3	58.2	25	31.5	—	23.05	41	M5 x 0.8	12.9	98
DAS5R-04	ø4							59.5	58.4							13.8	94
DAS5L-06	ø6							58.5	57.4							14.2	90
DAS5R-06	ø6							58.5	57.4							14.2	90
DAS5L-08	ø8	71	29	16.5	58.1	43.2	29.2	76.3	74.8	35	68.6	27	—	51	M5 x 0.8	18.9	313
DAS7-08	ø8							76.8	75.3							21	285
DAS7-10	ø10							74.7	73.2							21.9	252
DAS7L-08	ø8							76.3	74.8							18.9	190
DAS7R-08	ø8							76.3	74.8							18.9	190
DAS7L-10	ø10							76.8	75.3							21	186
DAS7R-10	ø10							76.8	75.3							21	186
DAS7L-12	ø12							74.7	73.2							21.9	171
DAS7R-12	ø12	74.7	73.2	21.9	171												

DAS Series

Dimensions/Inch Size

Mounting on one side (Left side)

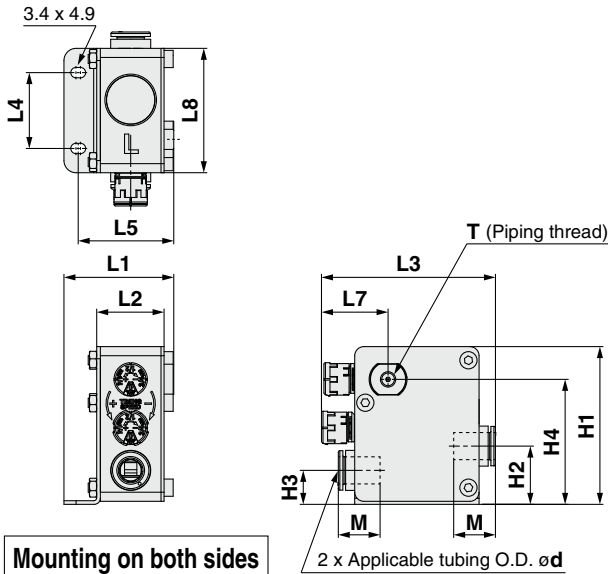

Mounting on one side (Right side)

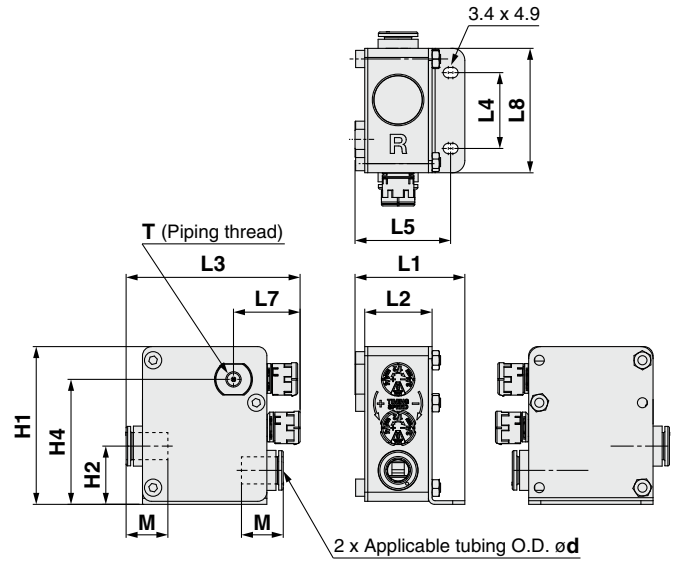

Mounting on both sides

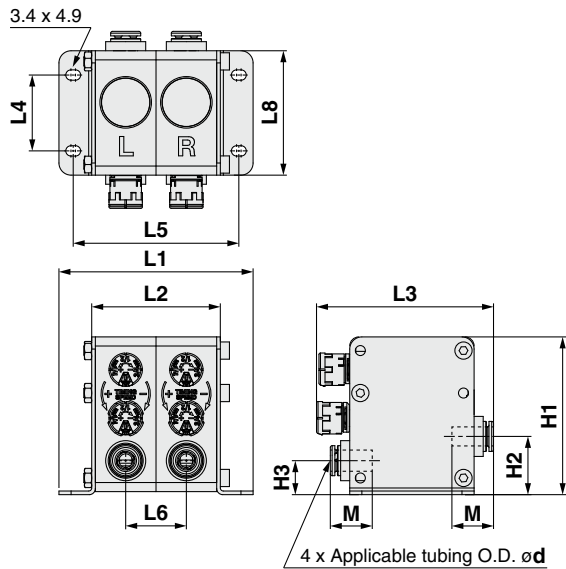

Model	d	H1	H2	H3	H4	L1	L2	L3		L4	L5	L6	L7	L8	T	M	Weight [g]					
								Unlocked	Locked													
DAS5-03	ø5/32"	52	19.2	11.2	—	64	42.4	59.3	58.2	25	54.6	20	—	41	—	12.9	151					
DAS5-07	ø1/4"				59.5			58.4	13.8							138						
DAS5-09	ø5/16"				58.5			57.4	14.2							134						
DAS5L-03	ø5/32"				59.3	58.2	41.2	36.2	22.2		59.5	58.4	31.5		—	23.05	M5 x 0.8	12.9	98			
DAS5R-03	ø5/32"				59.5	58.4					13.8	93										
DAS5L-07	ø1/4"				58.5	57.4					14.2	90										
DAS5R-07	ø1/4"				58.5	57.4					14.2	90										
DAS5L-09	ø5/16"				71	29	16.5	—	78		56.4	76.3	74.8		35	68.6	27	—	51	—	18.9	313
DAS5R-09	ø5/16"											76.7	75.2								20.9	290
DAS7-09	ø5/16"	74.1	72.6	21.9						252												
DAS7L-09	ø5/16"	76.3	74.8	58.1				43.2	29.2	76.3	74.8	38.5	—	26.9		M5 x 0.8	18.9	191				
DAS7R-09	ø5/16"	76.7	75.2							20.9	179											
DAS7L-11	ø3/8"	76.7	75.2							20.9	179											
DAS7R-11	ø3/8"	76.7	75.2							20.9	179											
DAS7L-13	ø1/2"	71	29	16.5				—	78	56.4	74.1	72.6	35	68.6		27	—	51		—	21.3	160
DAS7R-13	ø1/2"										74.1	72.6									21.3	160



DAS Series Specific Product Precautions 1

Be sure to read this before handling the products. Refer to the back cover for safety instructions. For flow control equipment precautions, refer to the “Handling Precautions for SMC Products” and the “Operation Manual” on the SMC website: <https://www.smcworld.com>

Parts and Names of Products

For double-end

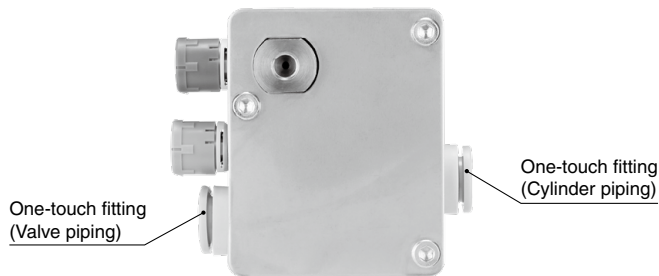

For single-end

(L type shown)

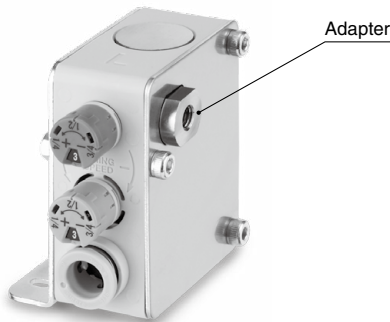

Design and Selection

Warning

1. Check the specifications.

The products are designed to be used in compressed air systems (including vacuum) only.

If the products are used in an environment where pressure or temperature is out of the specified range, damage and/or malfunction may result. Do not use under such conditions. (Refer to the specifications.)

We do not guarantee against any damage if the product is used outside of the specification range.

2. This product is designed to perform deceleration of the cylinder stroke and cannot be used for a complete accurate and precise intermediary stop of the actuator.

Design and Selection

Caution

1. Check the range in which the deceleration timing can be adjusted.

Check the range in which the deceleration timing can be adjusted by using the following formula as a guide.

It may be difficult to control the deceleration timing with this product depending on the cylinder stroke and initial velocity.

* When you make adjustment for the first time, adjust the speed by setting the number of speed controller rotations from fully closed position to four to five rotations. The cylinder may extend suddenly if the cylinder is not pressurized. Make adjustment by paying attention to the surrounding areas.

$$0.4^{*1} < \frac{\text{Cylinder stroke (mm)}}{\text{Cylinder initial velocity (mm/sec)}}$$

*1 Switching time 0.4 (sec)

Minimum switching time 0.3 sec. / guideline switching stroke 75% \approx 0.4

Example) When a cylinder whose stroke is 50 mm is operated at 100 mm/sec, the formula is: $50/100 = 0.5$. As the value is greater than 0.4, deceleration control is possible.

When a cylinder whose stroke is 50 mm is operated at 200 mm/sec, the formula is: $50/200 = 0.25$. As the value is smaller than 0.4, deceleration control is not possible.

2. Pay attention to the load weight.

Set the load weight of each cylinder by following the procedures for selecting a product by model selection. This product controls the cylinder velocity by increasing the back pressure through compression of the air in the cylinder. Therefore, if the 2nd speed knob (gray) is excessively throttled, the cylinder may bounce at the stroke end depending on the load weight or initial velocity. When an adequate deceleration is not possible due to forces such as moment of inertia, set the deceleration timing earlier or decrease the initial cylinder velocity.

3. Pay attention to the piping tube length.

The larger the piping volume between the product (deceleration controller) and cylinder, the lower the deceleration effect as because the back pressure does not increase.

We recommend that you install the product as close to the cylinder as possible. When the piping tube is long, adjust the tube length by referring to the formula below as a guide.

$$\frac{[\text{Cylinder bore size (mm)}]^2}{[\text{Piping tube I.D. (mm)}]^2} \times \text{Cylinder stroke (mm)} \times (1 - 0.75)^{*2} > \text{Tube length (mm)}$$

Example) When connecting TU0604 tube to the cylinder (ϕ 25, 500 mm stroke) and starting deceleration at 75% point of the stroke length.

The formula is: $(25/4)^2 \times 500 \times (1 - 0.75) > 4,882$. Therefore, the piping tube must be 4.8 m or shorter.

*2 When starting deceleration at 75% point of the cylinder stroke length, insert multiplication by 0.25 (= 1 - 0.75). When starting deceleration at 90% point of the cylinder stroke length, insert multiplication by 0.1 (= 1 - 0.9).

When the piping tube length cannot be adjusted in the above range, set the deceleration timing earlier or decrease the initial cylinder velocity.



DAS Series Specific Product Precautions 2

Be sure to read this before handling the products. Refer to the back cover for safety instructions. For flow control equipment precautions, refer to the “Handling Precautions for SMC Products” and the “Operation Manual” on the SMC website: <https://www.smcworld.com>

Design and Selection

⚠ Caution

- When using the product along with the built-in air cushion incorporated in the cylinder, pay attention to the adjustment method.

If an air cushion is already incorporated in the cylinder, the stroke movement may temporarily stop at the original air cushion position or the stick-slip phenomenon may occur during the 2nd speed setting of this product.

If this is the case, readjust the cushion needle incorporated in the cylinder by gradually opening the cushion needle.

Mounting

⚠ Warning

- Ensure sufficient space for maintenance activities.
When installing the products, allow access for maintenance.
- Check the piping direction, and then mount the product.
If this product is mounted in the opposite direction, speed adjustment and deceleration effect may not be observed, and the cylinder may suddenly move at an uncontrollable speed.



- Mount the product by using the mounting bracket.
When installing the product, use the mounting holes of the bracket bottom face and secure the product with M3 screws.

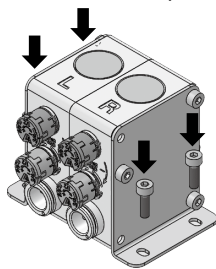

- After pushing the knob down to lock, confirm that it is locked.

Confirm that the knob is locked by pushing the knob in after adjusting the cylinder speed.

When the speed controller is unlocked, the set flow may change. If the knob is pulled with force while the speed controller is unlocked, it may result in breakage.

When it is unlocked, do not pull the knob out with force.

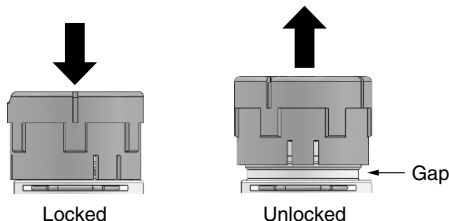

Mounting

⚠ Warning

- Slowly turn the knob in the opening direction or closing direction. (Guide for rotation speed: 1 [rev/sec] or below)
If quick reciprocal operations between two graduations like 0 → 1 → 0, which is not conducted in usual flow rate setting, are conducted, a scale malfunctioning may occur.
- Do not turn the knob forcibly to prevent the scale from going outside the scale display range.

The scale may indicate a wrong value, possibly leading to a wrong setting.

[Wrong use example] : While the scale indication range is 0 to 8, forcefully turning the knob in the opening direction from graduation 8 caused the scale to indicate 0.

Size	Target knob	Scale indication range
DAS5	Timing knob	0 to 8 graduations
	2nd speed knob	0 to 8 graduations
DAS7	Timing knob	0 to 8 graduations
	2nd speed knob	0 to 10 graduations

The timing knob and 2nd speed knob have a full-close stopper in the rotation direction. Table below shows the maximum allowable torque of the knob.

Size	Target knob	Max. allowable torque [N·m]
DAS5	Timing knob	0.04
	2nd speed knob	0.05
DAS7	Timing knob	0.04
	2nd speed knob	0.07

- Do not use tools such as pliers to rotate the knob.
It can cause idle rotation of the knob or damage.
- To adjust the 2nd speed knob, start with the knob in the fully closed position, and then make adjustment by turning it counterclockwise.
Depending on the opening adjustment condition of the knob (needle), the cylinder may suddenly move. Adjustment of the knob (needle) in the clockwise direction decreases the flow rate (closes), and its adjustment in the counterclockwise direction increases the flow rate (opens).
The actuator speed decreases when an adjustment in the clockwise direction is made and increases when an adjustment in the counterclockwise direction is made.
- Do not apply excessive force or shock to the body or fittings with an impact tool.
It can cause damage or air leakage.

⚠ Caution

- Cylinder speed check
Individual product difference due to tolerance of the components, individual cylinder difference, operating conditions and temperature, etc. may cause a large variation in the cylinder speed, and for this reason, the final cylinder speed needs to be checked every time the setting is changed.
- Lifting force for the knob

Force for lifting the knob is specified as shown in the table below. Lifting the knob with a lifting force larger than that specified in the table below will cause the knob to come off, make the cylinder setting speed or scale incorrect, or cause damage to the product.

Size	Target knob	Knob lifting force [N]
DAS5	Timing knob	1 to 1.5
	2nd speed knob	1 to 1.5
DAS7	Timing knob	1 to 1.5
	2nd speed knob	3 to 4



DAS Series Specific Product Precautions 3

Be sure to read this before handling the products. Refer to the back cover for safety instructions. For flow control equipment precautions, refer to the “Handling Precautions for SMC Products” and the “Operation Manual” on the SMC website: <https://www.smcworld.com>

Mounting

⚠ Caution

3. Do not apply excessive shocks (100 m/s² or more) to the product by dropping it or hitting it against another object during handling.

Even if the body appears undamaged, the internal components may be damaged, leading to a malfunction.

4. For mounting the fitting to the adapter (M5 size thread mounting)

1) Tightening method

First, tighten it by hand, then give it an additional 1/6 turn to 1/4 turn with a hexagon wrench. Refer to Table below for reference.

Connection thread size	Proper tightening torque [N·m]
M5	1 to 1.5

* Excessive tightening may damage the thread portion or deform the gasket and cause air leakage. If the screw is too shallowly screwed in, it may come loose or air may leak.

Piping

⚠ Caution

1. Refer to the Fittings and Tubing Precautions on the SMC website for handling One-touch fittings.
2. Preparation before piping

Before piping is connected, it should be thoroughly blown out with air (flushing) or washed to remove chips, cutting oil and other debris from inside the pipe.

Air Supply

⚠ Warning

1. Type of fluids

Be sure to use compressed air for the fluid.

2. When there is a large amount of drainage

Compressed air containing a large amount of drainage can cause the malfunction of pneumatic equipment. An air dryer or water separator should be installed upstream from filters.

3. Drain flushing

If condensation in the drain bowl is not emptied on a regular basis, the bowl will overflow. This may cause the malfunction of pneumatic equipment. If the drain bowl is difficult to check and remove, the installation of a drain bowl with an auto drain option is recommended.

For compressed air quality, refer to the **Web Catalog**.

4. Use clean air.

Do not use compressed air that contains chemicals, synthetic oils that include organic solvents, salt, corrosive gases, etc., as it can cause damage or malfunction.

Air Supply

⚠ Caution

1. Install an air filter.

Install an air filter at the upstream side of valve. Select a filtration rating of 5 μm or below, or that equivalent to or lower than ISO 8573-1:2010 [6:4:4]^{*1}

*1 This rating is equivalent to the rating produced when an air filter is installed for the purity class [7:4:4] of the inlet side compressed air.

2. Ensure that the fluid and ambient temperatures are within the specified range.

If the fluid temperature is 5°C or less, the moisture in the circuit could freeze, causing damage to the seals or equipment malfunction. Therefore, take appropriate measures to prevent freezing.

For compressed air quality, refer to the **Web Catalog**.

Operating Environment

⚠ Warning

1. Do not use in an atmosphere containing corrosive gases, chemicals, sea water, water, water steam, or where there is direct contact with any of these.
2. Do not expose the product to direct sunlight for an extended period of time.
3. Do not mount the product in locations where it is exposed to radiant heat.

Maintenance

⚠ Warning

1. Do not disassemble the product or make any modifications, including additional machining.

Doing so may cause human injury and/or an accident.

2. Perform maintenance and inspection according to the procedures indicated in the operation manual.

If handled improperly, malfunction or damage of machinery and equipment may occur.

3. Maintenance work

If handled improperly, compressed air can be dangerous. Assembly, handling, repair, and element replacement of pneumatic systems should be performed by a knowledgeable and experienced person.

4. Drain flushing

Remove drainage from air filters regularly.

5. Removal of equipment, and supply/exhaust of compressed air

Before components are removed, first confirm that measures are in place to prevent workpieces from dropping, run-away equipment, etc. Then, cut off the supply pressure and electric power, and exhaust all compressed air from the system using the residual pressure release function. When machinery is restarted, proceed with caution after confirming that appropriate measures are in place to prevent sudden movement.

Safety Instructions

These safety instructions are intended to prevent hazardous situations and/or equipment damage. These instructions indicate the level of potential hazard with the labels of “**Caution**,” “**Warning**” or “**Danger**.” They are all important notes for safety and must be followed in addition to International Standards (ISO/IEC)*1), and other safety regulations.

 **Caution:** **Caution** indicates a hazard with a low level of risk which, if not avoided, could result in minor or moderate injury.

 **Warning:** **Warning** indicates a hazard with a medium level of risk which, if not avoided, could result in death or serious injury.

 **Danger :** **Danger** indicates a hazard with a high level of risk which, if not avoided, will result in death or serious injury.

*1) ISO 4414: Pneumatic fluid power – General rules relating to systems.
ISO 4413: Hydraulic fluid power – General rules relating to systems.
IEC 60204-1: Safety of machinery – Electrical equipment of machines.
(Part 1: General requirements)
ISO 10218-1: Manipulating industrial robots – Safety.
etc.

Warning

1. The compatibility of the product is the responsibility of the person who designs the equipment or decides its specifications.

Since the product specified here is used under various operating conditions, its compatibility with specific equipment must be decided by the person who designs the equipment or decides its specifications based on necessary analysis and test results. The expected performance and safety assurance of the equipment will be the responsibility of the person who has determined its compatibility with the product. This person should also continuously review all specifications of the product referring to its latest catalog information, with a view to giving due consideration to any possibility of equipment failure when configuring the equipment.

2. Only personnel with appropriate training should operate machinery and equipment.

The product specified here may become unsafe if handled incorrectly. The assembly, operation and maintenance of machines or equipment including our products must be performed by an operator who is appropriately trained and experienced.

3. Do not service or attempt to remove product and machinery/equipment until safety is confirmed.

1. The inspection and maintenance of machinery/equipment should only be performed after measures to prevent falling or runaway of the driven objects have been confirmed.
2. When the product is to be removed, confirm that the safety measures as mentioned above are implemented and the power from any appropriate source is cut, and read and understand the specific product precautions of all relevant products carefully.
3. Before machinery/equipment is restarted, take measures to prevent unexpected operation and malfunction.

4. Contact SMC beforehand and take special consideration of safety measures if the product is to be used in any of the following conditions.

1. Conditions and environments outside of the given specifications, or use outdoors or in a place exposed to direct sunlight.
2. Installation on equipment in conjunction with atomic energy, railways, air navigation, space, shipping, vehicles, military, medical treatment, combustion and recreation, or equipment in contact with food and beverages, emergency stop circuits, clutch and brake circuits in press applications, safety equipment or other applications unsuitable for the standard specifications described in the product catalog.
3. An application which could have negative effects on people, property, or animals requiring special safety analysis.
4. Use in an interlock circuit, which requires the provision of double interlock for possible failure by using a mechanical protective function, and periodical checks to confirm proper operation.

Caution

1. The product is provided for use in manufacturing industries.

The product herein described is basically provided for peaceful use in manufacturing industries.
If considering using the product in other industries, consult SMC beforehand and exchange specifications or a contract if necessary.
If anything is unclear, contact your nearest sales branch.

Limited warranty and Disclaimer/ Compliance Requirements

The product used is subject to the following “Limited warranty and Disclaimer” and “Compliance Requirements”.

Read and accept them before using the product.

Limited warranty and Disclaimer

1. The warranty period of the product is 1 year in service or 1.5 years after the product is delivered, whichever is first.*2)
Also, the product may have specified durability, running distance or replacement parts. Please consult your nearest sales branch.
2. For any failure or damage reported within the warranty period which is clearly our responsibility, a replacement product or necessary parts will be provided.
This limited warranty applies only to our product independently, and not to any other damage incurred due to the failure of the product.
3. Prior to using SMC products, please read and understand the warranty terms and disclaimers noted in the specified catalog for the particular products.

*2) Vacuum pads are excluded from this 1 year warranty.

A vacuum pad is a consumable part, so it is warranted for a year after it is delivered.
Also, even within the warranty period, the wear of a product due to the use of the vacuum pad or failure due to the deterioration of rubber material are not covered by the limited warranty.

Compliance Requirements

1. The use of SMC products with production equipment for the manufacture of weapons of mass destruction (WMD) or any other weapon is strictly prohibited.
2. The exports of SMC products or technology from one country to another are governed by the relevant security laws and regulations of the countries involved in the transaction. Prior to the shipment of a SMC product to another country, assure that all local rules governing that export are known and followed.

Caution

SMC products are not intended for use as instruments for legal metrology.

Measurement instruments that SMC manufactures or sells have not been qualified by type approval tests relevant to the metrology (measurement) laws of each country. Therefore, SMC products cannot be used for business or certification ordained by the metrology (measurement) laws of each country.

 **Safety Instructions** Be sure to read the “Handling Precautions for SMC Products” (M-E03-3) and “Operation Manual” before use.

SMC Corporation

Akihabara UDX 15F,
4-14-1, Sotokanda, Chiyoda-ku, Tokyo 101-0021, JAPAN
Phone: 03-5207-8249 Fax: 03-5298-5362
<https://www.smcworld.com>
© 2023 SMC Corporation All Rights Reserved

Specifications are subject to change without prior notice
and any obligation on the part of the manufacturer.

D-G