

# 3-Color Display Digital Flow Switch

New



Applicable fluid **Dry air, N<sub>2</sub>**

**IP65**

## 3-color/2-screen display\*

\* 2-row display of main screen and sub screen



## Expanded flow range

Wide range of flow measurement with one product

Flow ratio\* **100:1**

\* Rated flow ratio is 10 : 1 for current PF2A.

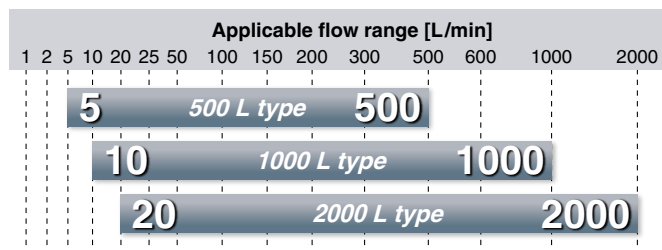

Setting resolution **1 L/min**

Current PF2A: 5 L/min

## Compact, Space saving

Compared with the current PF2A,

Weight **78% reduction** (1100 g → 240 g)  
 Mounting space **74% reduction**  
 Compared with PFMC7202-06 and PF2A703H-10

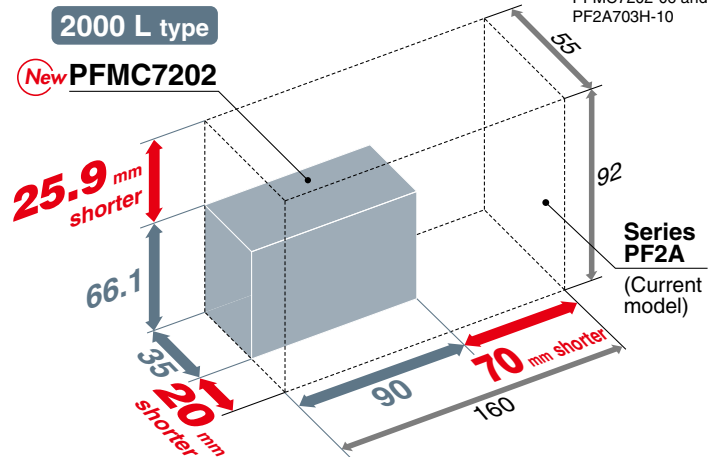

Series **PFMC**



CAT.ES100-115A

# 3-Color Display Digital Flow Switch Series PFMC

## Rotary display

Display can be rotated in increments of 45° to suit the installation conditions. Easy operation, improved visibility.

Counterclockwise 90°  
Clockwise 225°

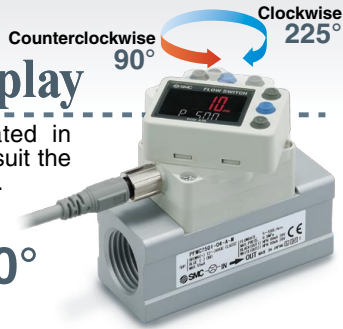

## Functions (Refer to pages 10 and 11 for details.)

- Output operation
- Display color
- Reference condition
- Setting of response time
- Display mode
- Selection of display on sub screen
- External input function
- Accumulated value hold
- Forced output function
- Analog output free range function
- Selection of display OFF mode
- Peak/Bottom value display
- Keylock function
- Error display function
- Orientation correction function

### Installation example

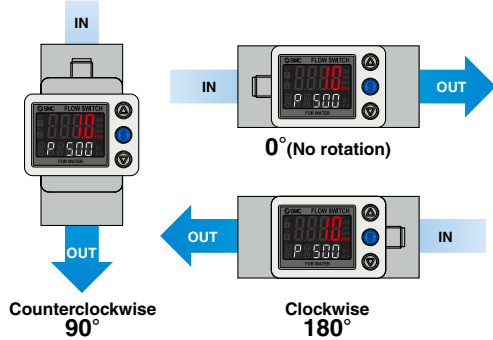

## Bypass structure

Bypass structure with protruding part at the main piping, reduces the contact of moist air with the sensor, reducing degradation of the sensor and maintaining accuracy.

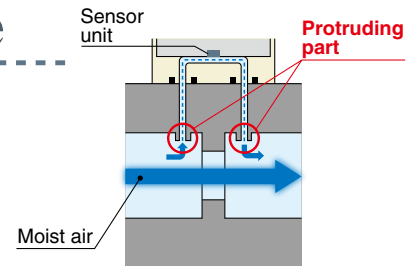

## Response time

Can be selected from **50 msec. (0.05 sec.) / 0.5 sec. / 1.0 sec. / 2.0 sec.**

Response time can be set depending on application.

**Grease-free**

## Applications

### Flow control of equipment, main line and branch line

Remote control is possible with accumulated pulse.

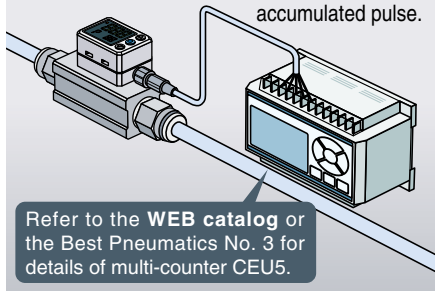

Refer to the WEB catalog or the Best Pneumatics No. 3 for details of multi-counter CEU5.

### Accumulated indication shows the operating flow rate or residual amount (of N<sub>2</sub> etc.) in a gas cylinder.

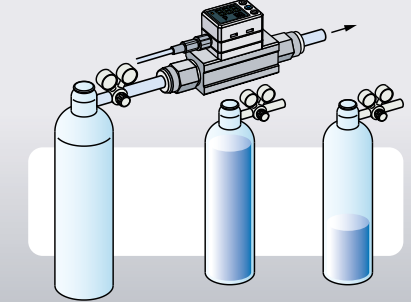

### Flow control of the air for spray painting

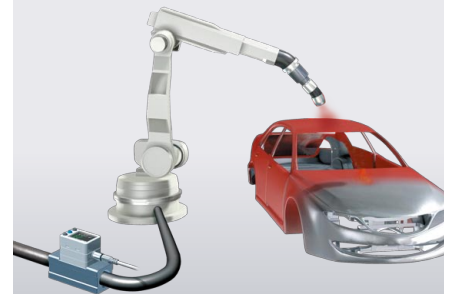

Note) The product is not designed to be explosion proof.

### Example of recommended pneumatic circuit

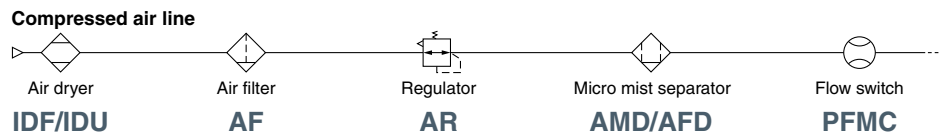

## Digital flow switch to save energy!





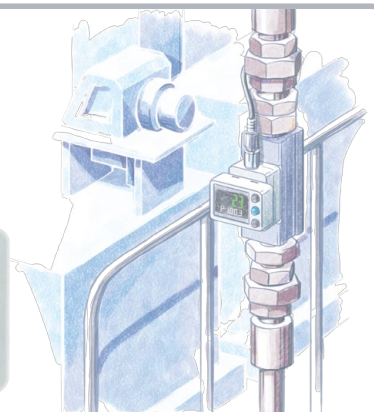

Flow control is necessary for promoting energy saving in any application. Saving energy starts from numerical control of the flow consumption of equipment and lines and clarification of the purpose and effect.

- Digital display allows **visualization**.
- **3-color/2-screen** display, Improved visibility
- **Remote control** is possible with accumulated pulse.



# Flow Switch Flow Rate Variations

Series	Applicable fluid	Detection method	Minimum setting unit	Applicable flow range [L/min]									
				-3	-2	-1	-0.5	0	0.5	1	2	3	
<b>PFMV</b> 	Air N <sub>2</sub>	Thermal type (MEMS)		0 0.5									
				0 1									
				0 3									
				-0.5 0.5									
				-1 1									
-3 3													

Series	Applicable fluid	Detection method	Minimum setting unit	Applicable flow range [L/min]															
				0.2	0.5	1	2	5	10	20	25	50	100	150	200	300	500	600	1000
<b>PFM</b> 	Air N <sub>2</sub> Argon CO <sub>2</sub>	Thermal type (MEMS)	0.01 L/min	10															
			0.1 L/min	25															
<b>PFMB</b>  	Dry air N <sub>2</sub>	Thermal type (MEMS) Bypass flow type	1 L/min	50															
				100															
				200															
				500															
<b>PFMC</b> 	Dry air N <sub>2</sub>	Thermal type (MEMS) Bypass flow type	1 L/min	1000															
				2000															
				5000															
<b>PF2A</b>  	Air N <sub>2</sub>	Thermal type (Thermistor)	0.1 L/min	10															
			0.5 L/min	50															
			1 L/min	100															
			2 L/min	200															
			5 L/min	500															
			5 L/min	3000															
10 L/min	6000																		
				12000															

# Flow Switch Variations/Basic Performance Table

Series	PFMV	PFM	PFMB	<b>New PFMC</b>	PF2A
Enclosure	IP40	IP40	IP40	<b>IP65</b>	IP65
Fluid	Air, N <sub>2</sub>	Air, N <sub>2</sub> , Ar, CO <sub>2</sub>	Dry air, N <sub>2</sub>	<b>Dry air, N<sub>2</sub></b>	Air, N <sub>2</sub>
Setting	Digital	Digital	Digital	<b>Digital</b>	Digital
Rated flow range	0 to 0.5 L/min 0 to 1 L/min 0 to 3 L/min -0.5 to 0.5 L/min -1 to 1 L/min -3 to 3 L/min	0.2 to 10 L/min 0.5 to 25 L/min 1 to 50 L/min 2 to 100 L/min	2 to 200 L/min 5 to 500 L/min 10 to 1000 L/min 20 to 2000 L/min	<b>5 to 500 L/min 10 to 1000 L/min 20 to 2000 L/min</b>	1 to 10 L/min 5 to 50 L/min 10 to 100 L/min 20 to 200 L/min 50 to 500 L/min 150 to 3000 L/min 300 to 6000 L/min 600 to 12000 L/min
Power supply voltage	24 VDC ±10%	24 VDC ±10%	12 to 24 VDC ±10%	<b>12 to 24 VDC ±10%</b>	12 to 24 VDC ±10%
Temperature characteristics (25°C reference)	±2% F.S. (15 to 35°C) ±5% F.S. (0 to 50°C) [Monitor unit: ±0.5% F.S. (0 to 50°C)]	±2% F.S. (15 to 35°C) ±5% F.S. (0 to 50°C)	±2% F.S. (15 to 35°C) ±5% F.S. (0 to 50°C)	<b>±2% F.S. (15 to 35°C) ±5% F.S. (0 to 50°C)</b>	±3% F.S. (15 to 35°C) ±5% F.S. (0 to 50°C) ±2% F.S. (PF2A7□□H: 0 to 50°C)
Repeatability	±1% F.S. (Fluid: Dry air) Analog output: ±5% F.S. [Monitor unit: ±0.1% F.S. Analog output: ±0.5% F.S.]	±1% F.S. (Fluid: Dry air) Analog output: ±3% F.S.	±1% F.S. (Fluid: Dry air)	<b>±1% F.S. (Fluid: Dry air)</b>	±1% F.S. (PF2A7□□, PF2A7□□H) ±2% F.S. (PF2A7□□1)
Hysteresis	Hysteresis mode: Variable Window comparator mode: Variable	Hysteresis mode: Variable Window comparator mode: Variable	Hysteresis mode: Variable Window comparator mode: Variable	<b>Hysteresis mode: Variable Window comparator mode: Variable</b>	Hysteresis mode: Variable Window comparator mode: Fixed (3 digits)
Output	NPN/PNP open collector Analog voltage output Analog current output	NPN/PNP open collector Accumulated pulse output Analog voltage output Analog current output	NPN/PNP open collector Accumulated pulse output Analog voltage output Analog current output	<b>NPN/PNP open collector Accumulated pulse output Analog voltage output Analog current output</b>	NPN/PNP open collector Accumulated pulse output
Display	2-color LCD display	2-color LED display	2-color LED display 2-color LCD display	<b>3-color LCD display</b>	LED display

# 3-Color Display

# Digital Flow Switch

## Series PFMC



RoHS



### How to Order

PFMC 7 **501** - **04** - **A** - **M**

#### Rated flow range

<b>501</b>	5 to 500 L/min
<b>102</b>	10 to 1000 L/min
<b>202</b>	20 to 2000 L/min

#### Thread type

<b>Nil</b>	Rc
<b>N</b>	NPT
<b>F</b>	G Note 1)

Note 1) ISO228 compliant

#### Port size

Symbol	Port size	Rated flow range		
		<b>501</b>	<b>102</b>	<b>202</b>
<b>04</b>	1/2	●	●	—
<b>06</b>	3/4	—	—	●

#### Output specifications

Symbol	OUT1	OUT2
<b>A</b>	NPN	NPN
<b>B</b>	PNP	PNP
<b>C</b>	NPN	Analog (1 to 5 V)
<b>D</b>	NPN	Analog (4 to 20 mA)
<b>E</b> Note 2)	PNP	Analog (1 to 5 V)
<b>F</b> Note 2)	PNP	Analog (4 to 20 mA)
<b>G</b> Note 2)	NPN	External input Note 3)
<b>H</b> Note 2)	PNP	External input Note 3)

Note 2) Made to Order

Note 3) Can be selected from accumulated flow external reset and peak/bottom reset.

#### Calibration certificate

<b>Nil</b>	None
<b>A</b> Note 8)	Yes

Note 8) Made to Order: Certificate in both English and Japanese

#### Option 2

<b>Nil</b>	No bracket
<b>R</b>	With bracket Note 7)

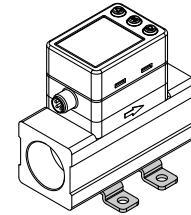

Note 7) Each option is not assembled with the product, but shipped together.

#### Unit specifications

<b>Nil</b>	Unit selection function Note 5)
<b>M</b>	SI unit only Note 6)

Note 5) Since the unit for Japan is fixed to SI due to new measurement law, this option is for overseas.

Note 6) Fixed unit: Instantaneous flow: L/min, Accumulated flow: L

#### Option 1

<b>Nil</b>	With lead wire and M8 connector (3 m) Note 4)
<b>N</b>	Without lead wire and M8 connector

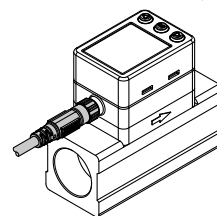

Note 4) Each option is not assembled with the product, but shipped together.

#### Option/Part No.

When only optional parts are required, order with the part number listed below.

Part no.	Option	Note
<b>ZS-40-A</b>	Lead wire and M8 connector	Length: 3 m
<b>ZS-42-A</b>	Bracket	Mounting screw for PFMC7501/7102 (M3 x 5, 2 pcs.)
<b>ZS-42-B</b>	Bracket	Mounting screw for PFMC7202 (M3 x 5, 2 pcs.)



# Series PPMC

For Flow Switch Precautions, refer to “Handling Precautions for SMC Products” on SMC website. For Specific Product Precautions, refer to the Operation Manual on SMC website.

## Specifications

Model		PFMC7501	PFMC7102	PFMC7202	
Fluid	Applicable fluid	Dry air, N <sub>2</sub> (Air quality grade is JIS B 8392-1 1.1.2 to 1.6.2, ISO 8573-1 1.1.2 to 1.6.2.)			
	Fluid temperature range	0 to 50°C			
Flow	Detection method	Thermal type			
	Rated flow range	5 to 500 L/min	10 to 1000 L/min	20 to 2000 L/min	
	Set flow rate range	Instantaneous flow	5 to 525 L/min	10 to 1050 L/min	20 to 2100 L/min
		Accumulated flow	0 to 999,999,990 L		
	Minimum setting unit	Instantaneous flow	1 L/min		
		Accumulated flow	10 L		
	Accumulated volume per pulse (Pulse width = 50 msec.)	1 L/pulse	10 L/pulse		
Accumulated value hold function <sup>Note 1)</sup>	Interval of 2 or 5 minutes can be selected.				
Pressure	Rated pressure range	0 to 0.8 MPa			
	Proof pressure	1.2 MPa			
	Pressure loss	Refer to “Pressure Loss” graph.			
	Pressure characteristics <sup>Note 2)</sup>	±5% F.S. (0 to 0.8 MPa, 0.6 MPa reference)			
Electrical	Power supply voltage	12 to 24 VDC ±10% Ripple (p-p) 10% or less			
	Current consumption	55 mA or less			
	Protection	Polarity protection			
Accuracy	Display accuracy	±3% F.S.			
	Analog output accuracy	±3% F.S.			
	Repeatability	±1% F.S. (±2% F.S. when response time is set to 0.05 seconds.)			
	Temperature characteristics	±5% F.S. (0 to 50°C, 25°C reference)			
Switch output	Output type	NPN open collector PNP open collector			
	Output mode	Select from Hysteresis, Window comparator, Accumulated output or Accumulated pulse output modes.			
	Switch operation	Select from Normal or Reversed output.			
	Maximum load current	80 mA			
	Maximum applied voltage (NPN only)	28 VDC			
	Internal voltage drop (Residual voltage)	NPN output type: 1 V or less (at load current 80 mA) PNP output type: 1.5 V or less (at load current 80 mA)			
	Response time <sup>Note 3)</sup>	Select from 0.05 sec., 0.1 sec., 0.5 sec., 1 sec., or 2 sec.			
	Hysteresis <sup>Note 4)</sup>	Variable from 0			
	Protection	Short circuit protection			
Analog output <sup>Note 5)</sup>	Output type	Voltage output: 1 to 5 V, Current output: 4 to 20 mA Output impedance: Approx. 1 kΩ			
	Impedance	Voltage output	Maximum load impedance at power supply voltage 24 V: 600 Ω, at power supply voltage 12 V: 300 Ω		
		Current output	Minimum load impedance: 50 Ω		
	Response time <sup>Note 6)</sup>	Linked with the response time of the switch output.			
External input <sup>Note 7)</sup>	External input	Input voltage: 0.4 V or less (Reed or Solid state) for 30 msec. or longer			
	Input mode	Accumulated flow external reset, Peak/Bottom reset			
Display	Reference condition <sup>Note 8)</sup>	Select from Standard condition or Normal condition.			
	Unit <sup>Note 9)</sup>	Instantaneous flow	L/min, cfm (ft <sup>3</sup> /min)		
		Accumulated flow	L, ft <sup>3</sup>		
	Displayable range	Instantaneous flow	-25 to 525 L/min (Displays [0] when value is within -4 to 4 L/min range.)	-50 to 1050 L/min (Displays [0] when value is within -9 to 9 L/min range.)	-100 to 2100 L/min (Displays [0] when value is within -19 to 19 L/min range.)
		Accumulated flow	0 to 999,999,999 L		
	Minimum display unit	Instantaneous flow	1 L/min		
		Accumulated flow	10 L		
Display	LCD, 2-screen display (Main screen/Sub screen) Main screen: Red/Green, Sub screen: White Main screen: 4 digits, 7 segment, Sub screen: 6 digits, 11 segment				
Indicator LED	LED ON when switch output is ON. (OUT1/OUT2: Orange)				
Environmental	Enclosure	IP65			
	Withstand voltage	250 VAC for 1 minute between terminals and housing			
	Insulation resistance	2 MΩ or more (50 VDC measured via megohmmeter) between terminals and housing			
	Operating temperature range	Operation: 0 to 50°C, Storage: -10 to 60°C (No condensation or freezing)			
Operating humidity range	Operation, Storage: 35 to 85% RH (No condensation or freezing)				
Standard	CE, RoHS				
Piping specifications	Rc1/2, NPT1/2, G1/2		Rc3/4, NPT3/4, G3/4		
Materials of parts in contact with fluid	Stainless steel 304, PPS, Aluminum alloy, HNBR, Si, Au, GE4F				
Weight	Piping specifications	Rc thread NPT thread	160 g	240 g	
		G thread	170 g	245 g	
	Lead wire	+80 g			
	Bracket	+25 g	+30 g		

Note 1) When using the accumulated value hold function, use the operating conditions to calculate the product life, and do not exceed it. The maximum access limit of the memory device is 1 million cycles. If the product is operated 24 hours per day, the product life will be as follows:  
 • 5 min interval: life is calculated as 5 min x 1 million = 5 million min = 9.5 years  
 • 2 min interval: life is calculated as 2 min x 1 million = 2 million min = 3.8 years  
 If the accumulated flow external reset is repeatedly used, the product life will be shorter than calculated life.

Note 2) Do not release the OUT side piping port of the product directly to the atmosphere without connecting piping. If the product is used with the piping port released to atmosphere, accuracy may vary.

Note 3) The time from when the flow is changed by a step input (when the flow

rate changes from 0 to the maximum flow instantaneously) until the switch output turns ON (or OFF) when set at 90% of the rated flow rate.

Note 4) If the flow fluctuates around the set value, the width for setting more than the fluctuating width needs to be set. Otherwise, chattering will occur.

Note 5) Setting is only possible for models with analog output.

Note 6) The time from when the flow is changed as a step input (when the flow rate changes from 0 to the maximum flow instantaneously) until the analog output reaches 90% of the rated flow rate.

Note 7) Setting is only possible for models with external input.

Note 8) The flow rate given in the specification is the value at standard condition.

Note 9) Setting is only possible for models with the unit selection function.

## Flow Range

Model	Flow range					
	-100 L/min	0 L/min	200 L/min	500 L/min	1000 L/min	2000 L/min
PFMC7501		5 L/min	500 L/min			
		5 L/min	525 L/min			
		-25 L/min	525 L/min			
PFMC7102		10 L/min	1000 L/min			
		10 L/min	1050 L/min			
		-50 L/min	1050 L/min			
PFMC7202		20 L/min	2000 L/min			
		20 L/min	2100 L/min			
	-100 L/min		2100 L/min			

Rated flow range  
  Set flow rate range  
  Displayable range

## Analog Output

### Flow/Analog Output

	A	B	C
Voltage output	1 V	1.04 V	5 V
Current output	4 mA	4.16 mA	20 mA

Model	Minimum flow of rated flow range	Maximum flow of rated flow range
PFMC7501	5 L/min	500 L/min
PFMC7102	10 L/min	1000 L/min
PFMC7202	20 L/min	2000 L/min

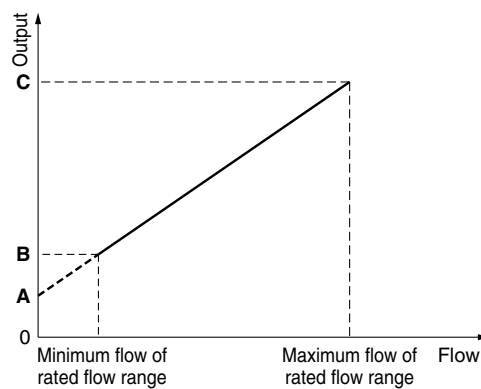

## Pressure Loss (Reference Data)

### PFMC7501 (for 500 L/min)

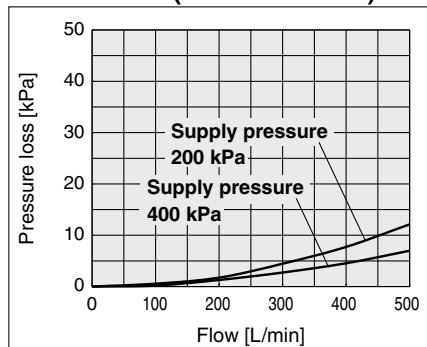

### PFMC7102 (for 1000 L/min)

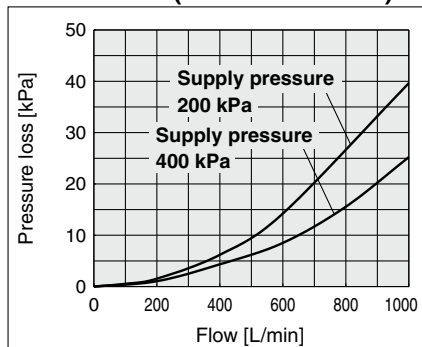

### PFMC7202 (for 2000 L/min)

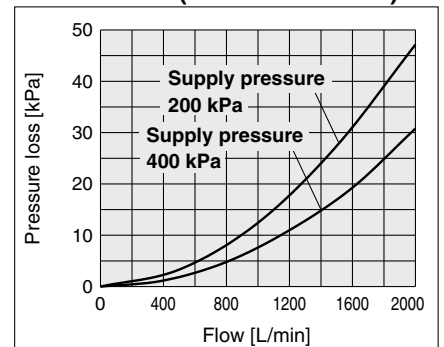

## IN Side Straight Piping Length and Accuracy (Reference Value)

- The piping on the IN side must have a straight section of piping with a length of 8 cm or more. If a straight section of piping is not installed, the accuracy can vary by approximately  $\pm 2\%$  F.S.
- \* "Straight section" means a part of the piping without any bends or rapid changes in the cross sectional area.
- When the PFMC7501 or 7102 is connected to tubing, use a tube I.D. 9 mm or more just before the product. The accuracy can vary by approximately  $\pm 2\%$  F.S. when such tubing is not used.

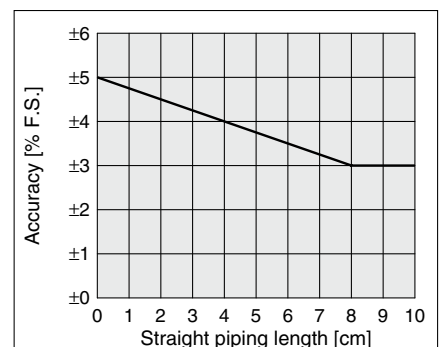
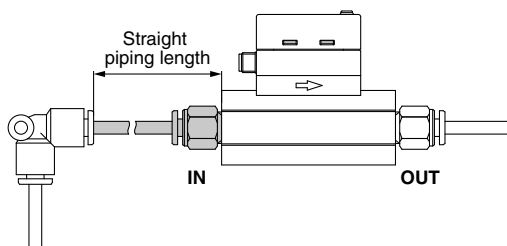

# Series PPMC

## Internal Circuits and Wiring Examples

### NPN (2 outputs) type

PFMC7□□□-□□-**A**□-□□□

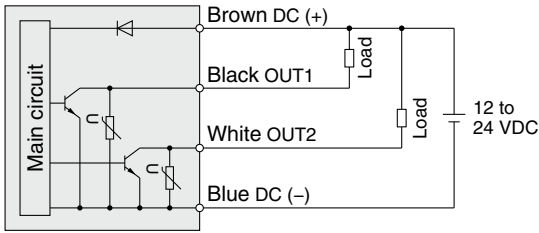

Max. applied voltage: 28 V, Max. load current: 80 mA, Internal voltage drop: 1 V or less

### PNP (2 outputs) type

PFMC7□□□-□□-**B**□-□□□

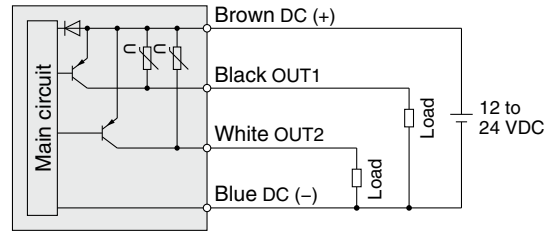

Max. load current: 80 mA, Internal voltage drop: 1.5 V or less

### NPN (1 output) + Analog (1 to 5 V) output type

PFMC7□□□-□□-**C**□-□□□

### NPN (1 output) + Analog (4 to 20 mA) output type

PFMC7□□□-□□-**D**□-□□□

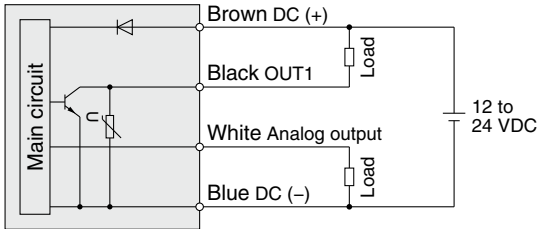

Max. applied voltage: 28 V, Max. load current: 80 mA, Internal voltage drop: 1 V or less

C: Analog output: 1 to 5 V

Output impedance: 1 kΩ

D: Analog output: 4 to 20 mA

Max. load impedance: 600 Ω

Min. load impedance: 50 Ω

### PNP (1 output) + Analog (1 to 5 V) output type

PFMC7□□□-□□-**E**□-□□□

### PNP (1 output) + Analog (4 to 20 mA) output type

PFMC7□□□-□□-**F**□-□□□

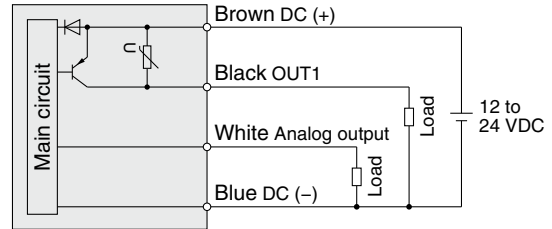

Max. load current: 80 mA, Internal voltage drop: 1.5 V or less

E: Analog output: 1 to 5 V

Output impedance: 1 kΩ

F: Analog output: 4 to 20 mA

Max. load impedance: 600 Ω

Min. load impedance: 50 Ω

### NPN (1 output) + External input type

PFMC7□□□-□□-**G**□-□□□

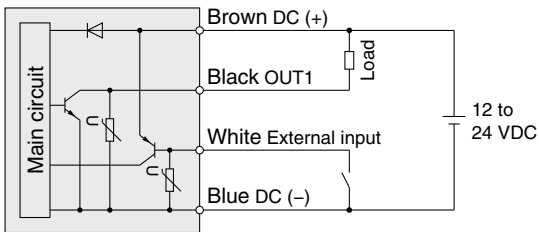

Max. applied voltage: 28 V, Max. load current: 80 mA, Internal voltage drop: 1 V or less

External input: input voltage 0.4 V or less (reed or solid state input) for 30 msec. or longer

### PNP (1 output) + External input type

PFMC7□□□-□□-**H**□-□□□

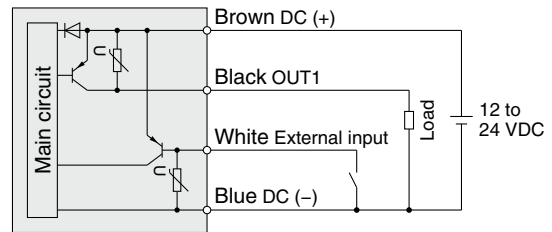

Max. load current: 80 mA, Internal voltage drop: 1.5 V or less

External input: input voltage 0.4 V or less (reed or solid state input) for 30 msec. or longer

## Accumulated pulse output wiring examples

### NPN (2 outputs) type

PFMC7□□□-□□-**A**□-□□□

### NPN (1 output) + Analog output type

PFMC7□□□-□□-**C**□-□□□

PFMC7□□□-□□-**D**□-□□□

### NPN (1 output) + External input type

PFMC7□□□-□□-**G**□-□□□

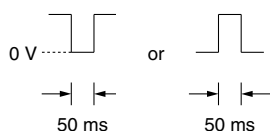
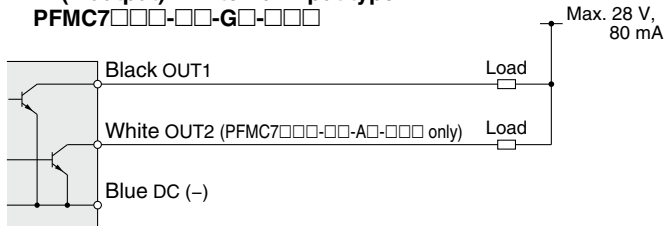

### PNP (2 outputs) type

PFMC7□□□-□□-**B**□-□□□

### PNP (1 output) + Analog output type

PFMC7□□□-□□-**E**□-□□□

PFMC7□□□-□□-**F**□-□□□

### PNP (1 output) + External input type

PFMC7□□□-□□-**H**□-□□□

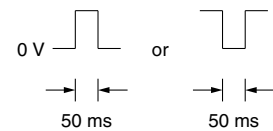
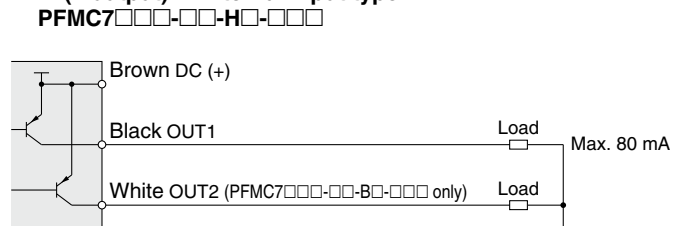



## Construction/Fluid Contact Parts

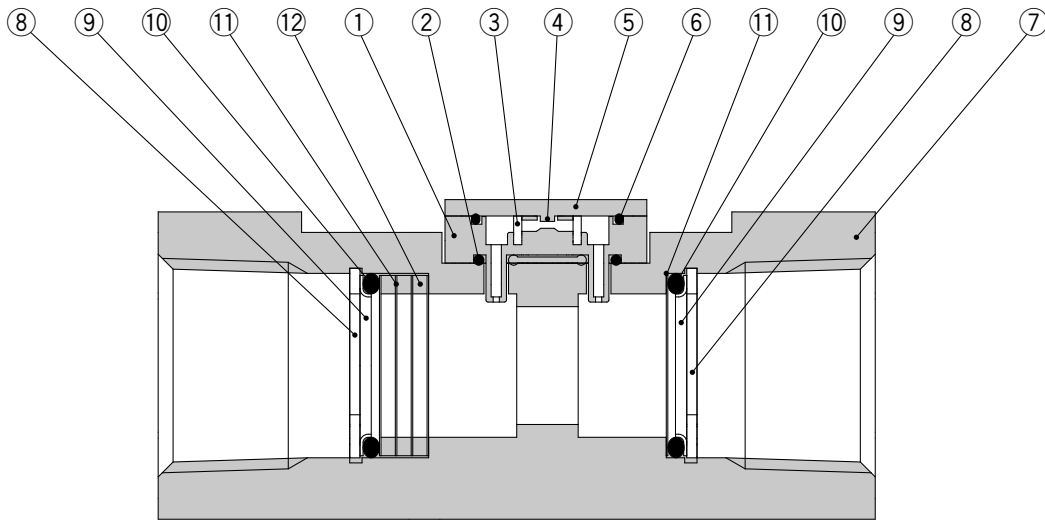

### Component Parts

No.	Description	Material	Note
1	<b>Sensor body</b>	PPS	
2	<b>Gasket</b>	HNBR	
3	<b>Flow rectifier</b>	Stainless steel 304	
4	<b>Sensor chip</b>	Silicon	
5	<b>Printed circuit board</b>	GE4F	
6	<b>Gasket</b>	HNBR	
7	<b>Body</b>	Aluminum alloy	Anodized
8	<b>Mesh</b>	Stainless steel 304	
9	<b>Spacer</b>	PPS	
10	<b>O-ring</b>	HNBR	
11	<b>Holder</b>	Stainless steel 304	
12	<b>Type C retaining ring</b>	Stainless steel 304	

# Series PFMC

## Dimensions

### PFMC7501/7102/7202

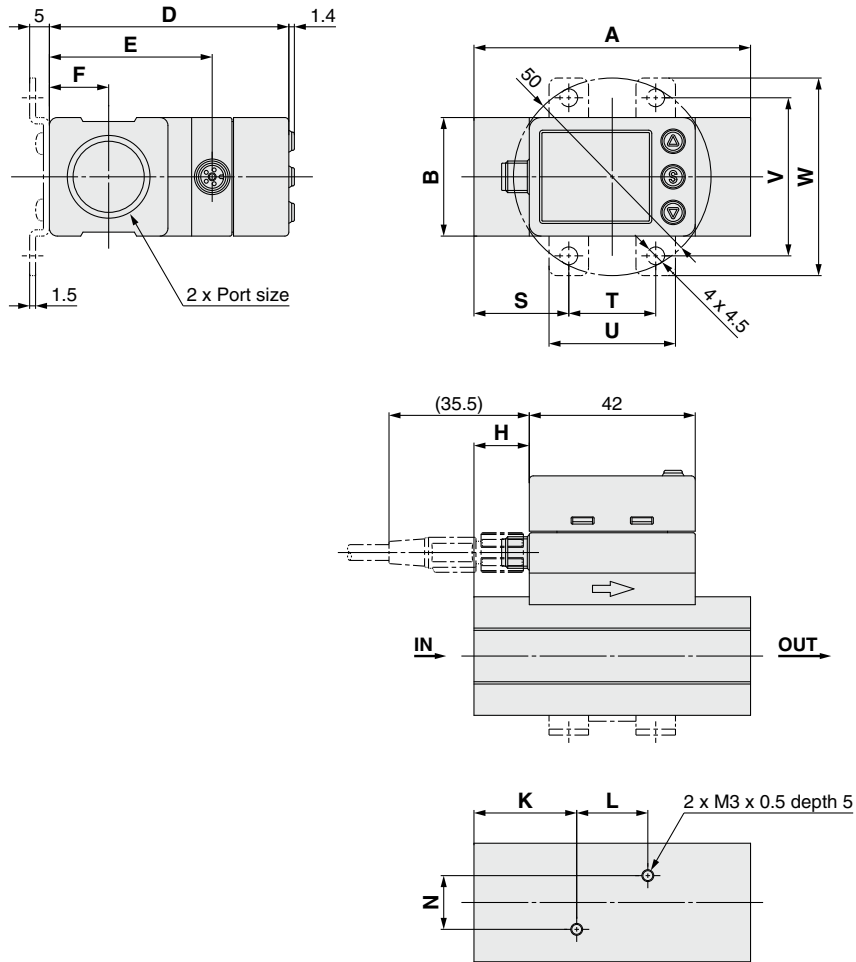

Model	Symbol	Port size	A	B	D	E	F	H	K	L	N
PFMC7501/7102		Rc1/2, NPT1/2	70	30	60.6	41.2	15	14	26	18	13.6
PFMC7202		Rc3/4, NPT3/4, G3/4	90	35	66.1	46.7	17.5	24	31	28	16.8
PFMC7501/7102		G1/2	76	30	60.6	41.2	15	14	26	18	13.6

Model	Symbol	Bracket dimensions				
		S	T	U	V	W
PFMC7501/7102		24	22	32	40	50
PFMC7202		30	30	42	48	58

## Lead wire and M8 connector ZS-40-A

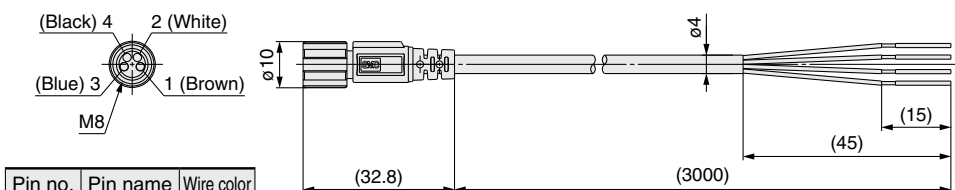

Pin no.	Pin name	Wire color
1	DC (+)	Brown
2	OUT2	White
3	DC (-)	Blue
4	OUT1	Black

Note) 4-wire type lead wire and M8 connector used for the PFMC7 series.  
Note) Refer to the Operation Manual in our website for wiring.

## Cable Specifications

Conductor	Nominal cross section	AWG23
	Outside diameter	Approx. 0.7 mm
Insulator	Material	Heat resistant PVC
	Outside diameter	Approx. 1.1 mm
Sheath	Color	Brown, White, Black, Blue
	Material	Heat and oil resistant PVC
Finished outside diameter		$\phi 4$

# Series PFMC

## Function Details

### Output operation

The output operation can be selected from the following:  
Output (hysteresis mode and window comparator mode) corresponding to instantaneous flow, or output (accumulated output and pulse output) corresponding to accumulated flow.

Note) At the time of shipment from the factory, it is set to hysteresis mode and normal output.

### Display color

The display color can be selected for each output condition. The selection of the display color provides visual identification of abnormal values. (The display color depends on OUT1 setting.)

Green for ON, Red for OFF
Red for ON, Green for OFF
Red all the time
Green all the time

### Reference condition

The display unit can be selected from standard condition or normal condition.

Standard condition: Flow rate converted to a volume at 20°C and 1 atm (atmosphere)
Normal condition: Flow rate converted to a volume at 0°C and 1 atm (atmosphere)

### Display mode

The display mode can be selected from instantaneous flow or accumulated flow.

Instantaneous flow display
Accumulated flow display

### Response time

The response time can be selected to suit the application. (Default setting is 1 second.)  
Abnormalities can be detected more quickly by setting the response time to 0.05 seconds.  
The effect of fluctuation and flickering of the display can be reduced by setting the response time to 2 seconds.

0.05 sec.
0.1 sec.
0.5 sec.
1 sec.
2 sec.

### Selection of display on sub screen

The display on the sub screen in measuring mode can be set.

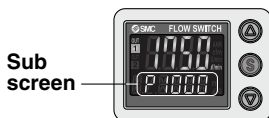

Set value display	Accumulated value display	Peak value display
Displays the set value. (The set value of OUT2 cannot be displayed.) 	Displays the accumulated value. (The accumulated value of OUT2 cannot be displayed.) 	Displays the peak value. 
Bottom value display	Line name display	OFF
Displays the bottom value. 	Displays the line name. (Up to 6 alphanumeric characters can be input.) 	Displays nothing. 

### Display OFF mode

This function will turn the display OFF. In this mode, decimal points flash on the main screen. If any button is pressed during this mode, the display reverts to normal for 30 seconds to allow checking of the flow etc.

### Setting of security code

The user can select whether a security code must be entered to release key lock. At the time of shipment from the factory, it is set such that the security code is not required.

### External input function

This function can be used only when the optional external input is present. The accumulated flow, peak value and bottom value can be reset remotely.

**Accumulated flow external reset:** A function to reset the accumulated flow value when an external input signal is applied.  
In accumulated increment mode, the accumulated value will reset to, and increase from zero.  
In accumulated decrement mode, the accumulated value will reset to, and decrease from the set value.

\* When the accumulated value is memorized, every time the accumulated flow external reset is activated, the memory device (EEPROM) will be accessed. Take into consideration the maximum number of times the memory device can be accessed, 1 million times. The total of external input times and accumulated value memorizing time interval should not exceed 1 million times.

**Peak/Bottom reset:** Peak and bottom value are reset.

### Forced output function

The output is turned on/off in a fixed state when starting the system or during maintenance. This enables confirmation of the wiring and prevents system errors due to unexpected output.

For the analog output type, when ON the output will be 5 V or 20 mA, and when OFF, it will be 1 V or 4 mA.

\* Also, the increase or decrease of the flow and temperature will not change the on/off status of the output while the forced output function is activated.

### Accumulated value hold

Accumulated value is not cleared even when the power supply is turned off.

The accumulated value is memorized every 2 or 5 minutes during measurement, and continues from the last memorized value when the power supply is turned on again.

The life time of the memory element is 1 million access cycles. Take this into consideration before using this function.

### Peak/Bottom value display

The maximum (minimum) flow rate is detected and updated from when the power supply is turned on. In peak (bottom) value display mode, this maximum (minimum) flow rate is displayed.

### Keylock function

Prevents operation errors such as accidentally changing setting values.

# Series PFMC

## ■ Analog output free range function

Allows the flow that generates an output of 5 V or 20 mA to be changed.  
The value can be changed 10% of maximum rated flow to maximum display value.

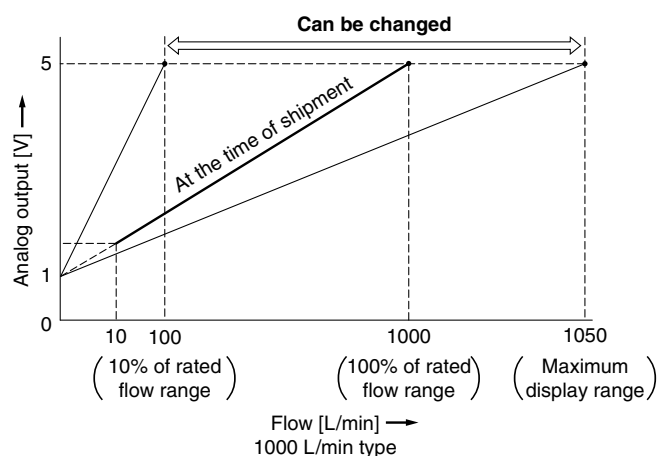

## ■ Error display function

When an error or abnormality arises, the location and contents are displayed.

Display	Description	Contents	Action	
Er1	OUT1 over current error	Load current of 80 mA or more is applied to the switch output (OUT1).	Eliminate the cause of the over current by turning off the power supply and then turn on it again.	
Er2	OUT2 over current error	Load current of 80 mA or more is applied to the switch output (OUT2).		
HHH	Instantaneous flow error	The flow rate exceeds the upper limit of indicated flow rate range.	Decrease the flow rate.	
LLL	Reverse flow error	There is a reverse flow equivalent to -5% or more.	Turn the flow to correct direction.	
999999999 (Alternately displays [999] and [999999].)	PFMC7501 PFMC7102 PFMC7202	Accumulated flow error	The flow rate exceeds the accumulated flow rate range.	Clear the accumulated flow rate.
Er0	System error	Displayed if an internal error has occurred.	Turn the power off and on again.	
Er4				
Er6				
Er8				

If the failure cannot be solved after the above instructions are performed, please contact SMC for investigation.

## Safety Instructions

These safety instructions are intended to prevent hazardous situations and/or equipment damage. These instructions indicate the level of potential hazard with the labels of “**Caution**,” “**Warning**” or “**Danger**.” They are all important notes for safety and must be followed in addition to International Standards (ISO/IEC)\*1), and other safety regulations.

 **Caution:** **Caution** indicates a hazard with a low level of risk which, if not avoided, could result in minor or moderate injury.

 **Warning:** **Warning** indicates a hazard with a medium level of risk which, if not avoided, could result in death or serious injury.

 **Danger:** **Danger** indicates a hazard with a high level of risk which, if not avoided, will result in death or serious injury.

\*1) ISO 4414: Pneumatic fluid power – General rules relating to systems.  
ISO 4413: Hydraulic fluid power – General rules relating to systems.  
IEC 60204-1: Safety of machinery – Electrical equipment of machines.  
(Part 1: General requirements)  
ISO 10218-1: Manipulating industrial robots – Safety.  
etc.

### Warning

#### 1. The compatibility of the product is the responsibility of the person who designs the equipment or decides its specifications.

Since the product specified here is used under various operating conditions, its compatibility with specific equipment must be decided by the person who designs the equipment or decides its specifications based on necessary analysis and test results. The expected performance and safety assurance of the equipment will be the responsibility of the person who has determined its compatibility with the product. This person should also continuously review all specifications of the product referring to its latest catalog information, with a view to giving due consideration to any possibility of equipment failure when configuring the equipment.

#### 2. Only personnel with appropriate training should operate machinery and equipment.

The product specified here may become unsafe if handled incorrectly. The assembly, operation and maintenance of machines or equipment including our products must be performed by an operator who is appropriately trained and experienced.

#### 3. Do not service or attempt to remove product and machinery/equipment until safety is confirmed.

1. The inspection and maintenance of machinery/equipment should only be performed after measures to prevent falling or runaway of the driven objects have been confirmed.
2. When the product is to be removed, confirm that the safety measures as mentioned above are implemented and the power from any appropriate source is cut, and read and understand the specific product precautions of all relevant products carefully.
3. Before machinery/equipment is restarted, take measures to prevent unexpected operation and malfunction.

#### 4. Contact SMC beforehand and take special consideration of safety measures if the product is to be used in any of the following conditions.

1. Conditions and environments outside of the given specifications, or use outdoors or in a place exposed to direct sunlight.
2. Installation on equipment in conjunction with atomic energy, railways, air navigation, space, shipping, vehicles, military, medical treatment, combustion and recreation, or equipment in contact with food and beverages, emergency stop circuits, clutch and brake circuits in press applications, safety equipment or other applications unsuitable for the standard specifications described in the product catalog.
3. An application which could have negative effects on people, property, or animals requiring special safety analysis.
4. Use in an interlock circuit, which requires the provision of double interlock for possible failure by using a mechanical protective function, and periodical checks to confirm proper operation.

### Caution

#### 1. The product is provided for use in manufacturing industries.

The product herein described is basically provided for peaceful use in manufacturing industries.  
If considering using the product in other industries, consult SMC beforehand and exchange specifications or a contract if necessary.  
If anything is unclear, contact your nearest sales branch.

### Limited warranty and Disclaimer/ Compliance Requirements

The product used is subject to the following “Limited warranty and Disclaimer” and “Compliance Requirements”.

Read and accept them before using the product.

#### Limited warranty and Disclaimer

1. The warranty period of the product is 1 year in service or 1.5 years after the product is delivered, whichever is first.\*2)  
Also, the product may have specified durability, running distance or replacement parts. Please consult your nearest sales branch.
2. For any failure or damage reported within the warranty period which is clearly our responsibility, a replacement product or necessary parts will be provided.  
This limited warranty applies only to our product independently, and not to any other damage incurred due to the failure of the product.
3. Prior to using SMC products, please read and understand the warranty terms and disclaimers noted in the specified catalog for the particular products.

##### \*2) Vacuum pads are excluded from this 1 year warranty.

A vacuum pad is a consumable part, so it is warranted for a year after it is delivered.  
Also, even within the warranty period, the wear of a product due to the use of the vacuum pad or failure due to the deterioration of rubber material are not covered by the limited warranty.

#### Compliance Requirements

1. The use of SMC products with production equipment for the manufacture of weapons of mass destruction (WMD) or any other weapon is strictly prohibited.
2. The exports of SMC products or technology from one country to another are governed by the relevant security laws and regulations of the countries involved in the transaction. Prior to the shipment of a SMC product to another country, assure that all local rules governing that export are known and followed.

### Caution

#### SMC products are not intended for use as instruments for legal metrology.

Measurement instruments that SMC manufactures or sells have not been qualified by type approval tests relevant to the metrology (measurement) laws of each country. Therefore, SMC products cannot be used for business or certification ordained by the metrology (measurement) laws of each country.

 **Safety Instructions** Be sure to read “Handling Precautions for SMC Products” (M-E03-3) before using.