

# NAAMS Standards Compliant Power Clamp Cylinder

**CKZ3N** -X2742A (Base Type)  
 -X2568□ (With Manual Handle)



ø50, ø63

## Weight reduced by up to 38%

- Aluminum body with greatly reduced weight
- Suitable for robot material handling

Bore size	CKZ2N → CKZ3N-X2742A	Reduction rate
50	5.1 kg → 3.2 kg	37% reduction
63	7.2 kg → 4.4 kg	38% reduction

\* Arm opening angle: 135°, Arm position: R

## Simple switch adjustment greatly reduces work hours

Switch can be adjusted easily when changing the arm opening angle.

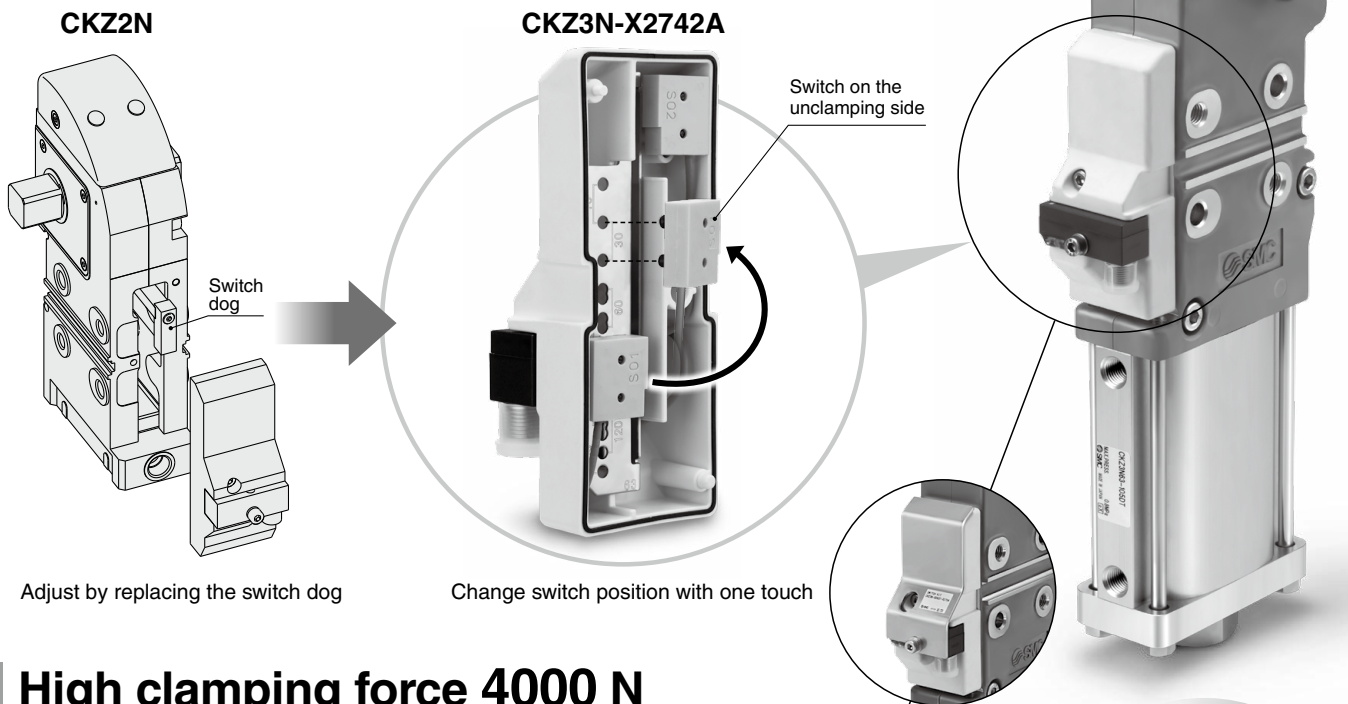

Adjust by replacing the switch dog

Change switch position with one touch

## High clamping force 4000 N

(ø63, Arm length: 100 mm, 0.5 MPa)

## Metal switch cassette cover (Option)

- Protects switch cassette from unexpected impact

## Manual handle (lock specification) is available.

- For manual workpiece setting processes
- The handle is held at unclamped position.

Manual handle  
(Unclamping position)

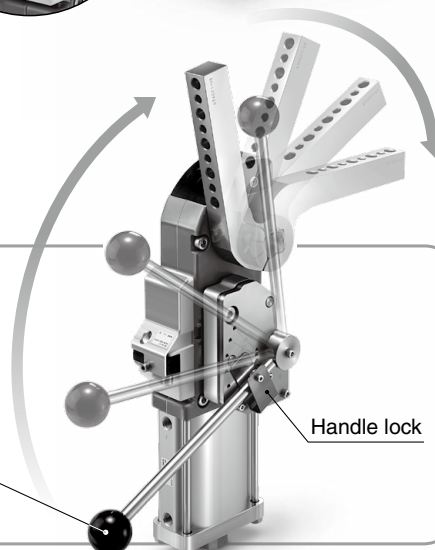

- CKZM16
- CKZT25/32
- CKZT40
- CKZ5T
- CKZ3T
- CKZT80
- CKZ5N
- CKZ3N
- CKZ2N
- CLJKQG□
- CLJKQP□
- CLJKQID
- CLJKQD -X3256
- CLJKQG32
- CLJKU32
- CLJKQG32
- CLJKU32 -X3036
- Flow Control Equipment
- Piping Equipment

# NAAMS Standards Compliant Power Clamp Cylinder

## CKZ3N-X2742A -X2568□

ø50, ø63



### How to Order

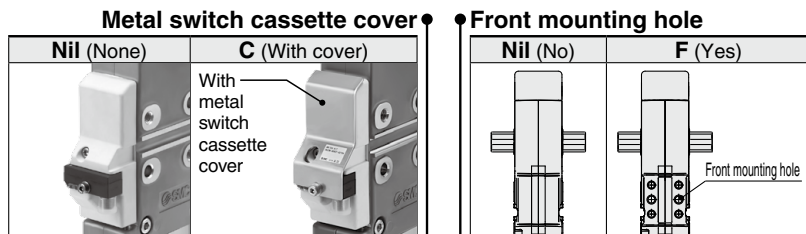

**Base type**

CKZ3N 63 - 120 R T F - X2742A

**With manual handle**

CKZ3N 63 - 120 R T C F - X2568 L



With manual handle

**Bore size**

50	ø50 equivalent
63	ø63 equivalent

**Cylinder port**

Nil	NPT
TF	G
TP	Rc

**Arm opening angle**

Symbol	Arm opening angle	Base type X2742A	With manual handle X2568□
15	15°	○	○
30	30°	○	○
45	45°	○	○
60	60°	○	○
75	75°	○	○
90	90°	○	○
105	105°	○	○
120	120°	○	○
135	135°	○	—

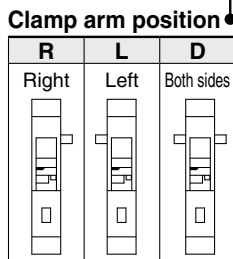

\* Proximity switch mounting surface viewed from the front

**Proximity switch**

T	TURCK
P	P&F
W	None

**Top cover material**

Nil	Rubber cover*1
M	Metal cover

\*1 Flame resistant (Equivalent to UL94 Standard V0)

- With front mounting hole
- With metal switch cassette cover

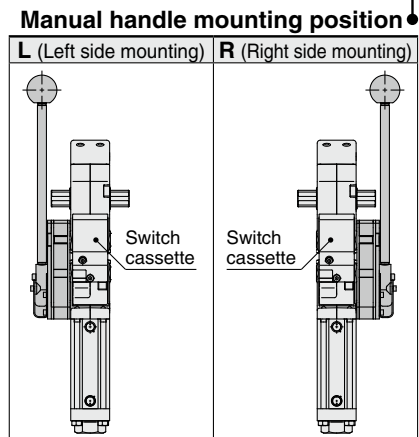

\* Switch cassette viewed from the front

**Clamp arm**

CKZ-63 A002



Mounted arm

**Bore size**

50	ø50 equivalent
63	ø63 equivalent

**Clamp arm code**  
(Refer to pages 102 to 105.)

## Cylinder Specifications

Bore size	50	63
Action	Double acting	
Fluid	Air	
Proof pressure	1.2 MPa	
Max. operating pressure	0.8 MPa	
Min. operating pressure	0.3 MPa	
Ambient and fluid temperatures	-10 to 60°C (No freezing)	
Cushion	Clamping side: None Unclamping side: Rubber bumper	
Operating time*1	Clamping: 1 sec. or more, Unclamping: 1 sec. or more	
Max. allowable holding moment*2	800 N·m	1500 N·m

\*1 Refer to the made-to-order -X3090 on page 111 for the large port orifice specification.

\*2 Refers to the maximum holding force (torque) while clamped with the operating air exhausted  
This is not the possible holding force (torque) for normal use.

## Weight (Cylinder Without Clamp Arm)

Bore size	Arm position	Arm opening angle									Extra weight is due to addition of the manual handle
		15°	30°	45°	60°	75°	90°	105°	120°	135°	
50	R/L	3.3	3.3	3.3	3.3	3.2	3.2	3.2	3.2	3.2	1.7
	D	3.4	3.3	3.3	3.3	3.3	3.3	3.3	3.2	3.2	
63	R/L	4.6	4.6	4.5	4.5	4.5	4.4	4.4	4.4	4.4	1.7
	D	4.7	4.7	4.6	4.6	4.6	4.5	4.5	4.5	4.5	

## Cylinder Stroke

Bore size	Arm opening angle									
	15°	30°	45°	60°	75°	90°	105°	120°	135°	
50	22.7	31.9	39.7	47.2	54.8	62.7	70.4	77.2	82.1	
63	24.2	34.2	42.6	50.6	58.7	66.9	74.8	81.6	86.4	

## Proximity Switch Specifications

Manufacturer	TURCK	P&F
Power supply voltage	10 to 30 VDC	10 to 30 VDC
Output	N.O., PNP	N.O., PNP
Continuous load current	150 mA	100 mA
Response frequency	30 Hz	25 Hz
Housing material	PBT	PA6, PBT
Output indication	Clamping side: Red Unclamping side: Yellow	Clamping side: Red Unclamping side: Yellow
Power supply indication	Green	Green
Connector	M12 connector	M12 connector

\* Switch specifications correspond to the manufacturers' technical information.

## Wiring Diagram (PNP Connection Circuit)

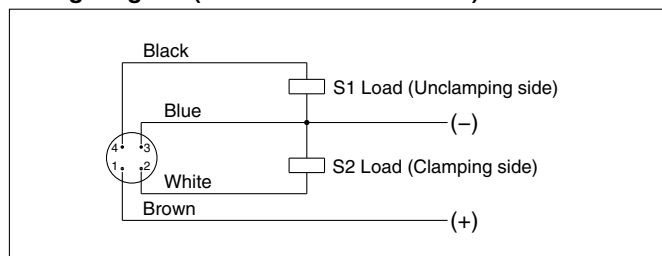

\* Applicable to both TURCK and P&F  
\* NPN specifications are made to order

Power Clamp Cylinders  
CKZM16  
CKZT25/32  
CKZT40  
CKZ5T  
CKZ3T  
CKZT80  
CKZ5N  
CKZ3N  
CKZ2N

Related Products  
C(L)KQG□  
C(L)KQP□  
C(L)KQ□D  
-X3256  
C(L)KQG32  
C(L)KU32  
C(L)KQG32  
-X3036  
Flow Control Equipment  
Piping Equipment

**Replacement Parts**

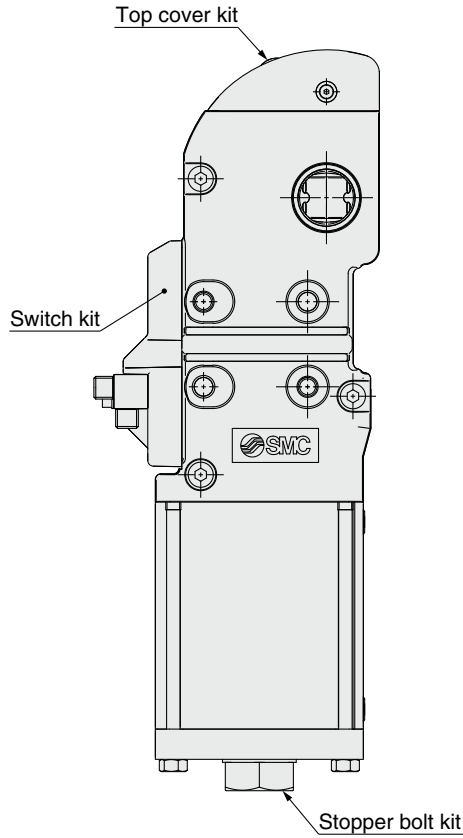

**Switch Kit No.**

**CKZ3N - S 050 T - X2742A**

**Bore size**

<b>050</b>	ø50 equivalent
<b>063</b>	ø63 equivalent

**Proximity switch**

<b>T</b>	TURCK
<b>P</b>	P&F
<b>W</b>	None

**Metal switch cassette cover**

<b>X2742A</b>	None
<b>X2734</b>	With cover

\* The switch kit includes a switch cassette assembly, metal switch cassette cover, and mounting brackets.

**Stopper Bolt Kit No.**

**CKZ3N - B 050 D**

**Bore size**

<b>050</b>	ø50 equivalent
<b>063</b>	ø63 equivalent

**Arm opening angle**

<b>J</b>	15°
<b>H</b>	30°
<b>G</b>	45°
<b>F</b>	60°
<b>E</b>	75°
<b>D</b>	90°
<b>C</b>	105°
<b>B</b>	120°
<b>A</b>	135°

\* The stopper bolt kit includes a stopper bolt and mounting brackets.

**Top Cover Kit No.**

**Rubber cover**

**CKZ2N - T 050**

**Bore size**

<b>050</b>	ø50 equivalent
<b>063</b>	ø63 equivalent

**Metal cover**

**CKZ3N - T 050 M**

**Bore size**

<b>050</b>	ø50 equivalent
<b>063</b>	ø63 equivalent

\* The top cover kit includes a top cover and mounting brackets.

\* Refer to page 110 for procedures for changing the stopper bolt and switch positions and for top cover replacement instructions.

## Dimensions: Base Type

### Rubber cover type

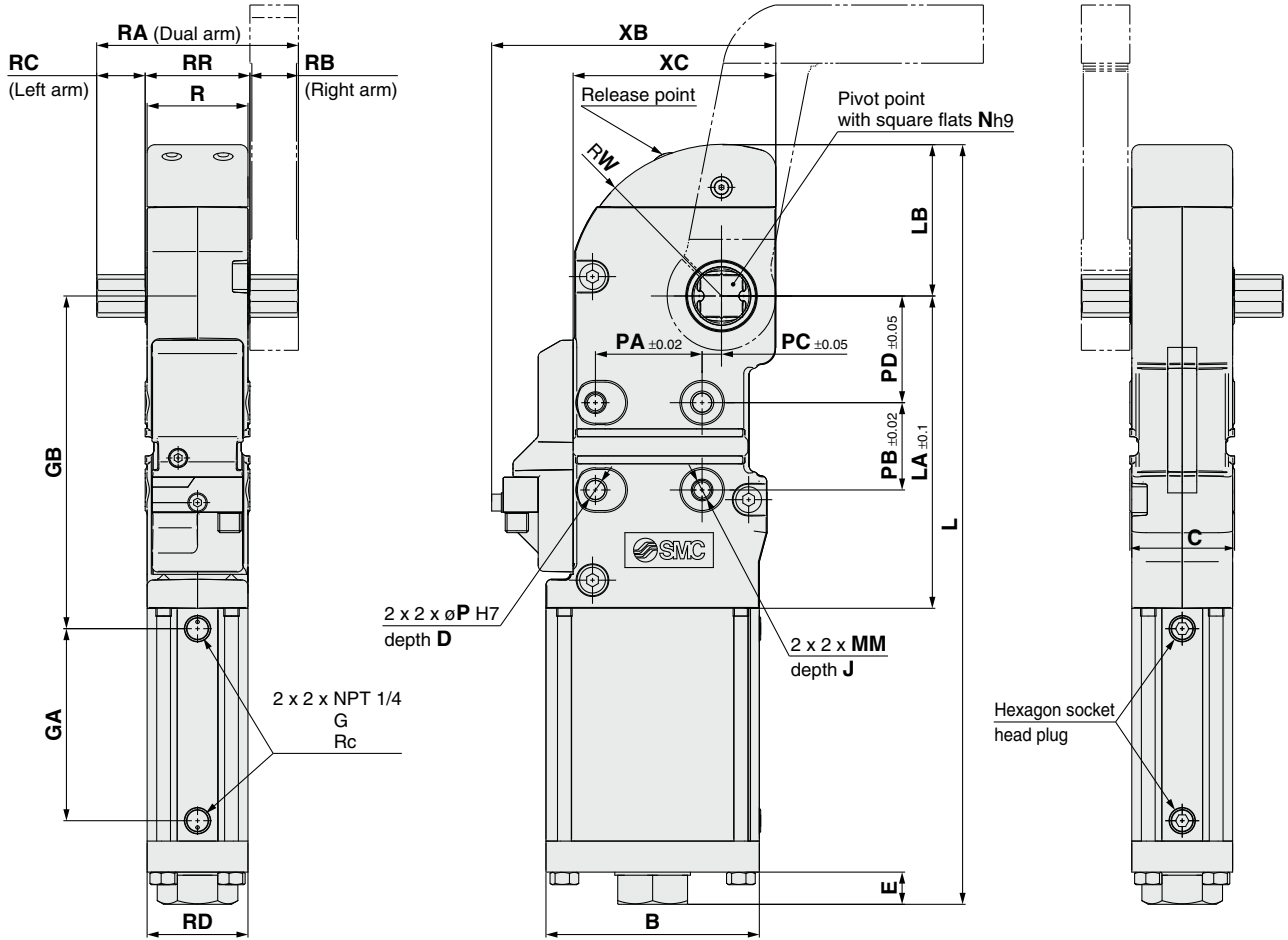

Bore size	B	C	D	E	GA	GB	J	L	LA	LB		MM	N	P
										Rubber cover	Metal cover			
50	92	48	12	13.7	95	166	12	376.6	155.5	78.4	78.4	M8 x 1.25	19	8
63	110	54	15	16.6	99	171.5	12	391.6	161	78	78.4	M10 x 1.5	22	10

  

Bore size	PA	PB	PC	PD	R	RA	RB	RC	RD	RR	W	XB		XC	Y
												Without switch cover	With switch cover		
50	45	45	5	40	46	88	20	20	46	48	78.4	134	136	92	132
63	55	45	10	55	52	104	25	25	52	54	78	146.5	148.5	104.5	138

### With front mounting hole

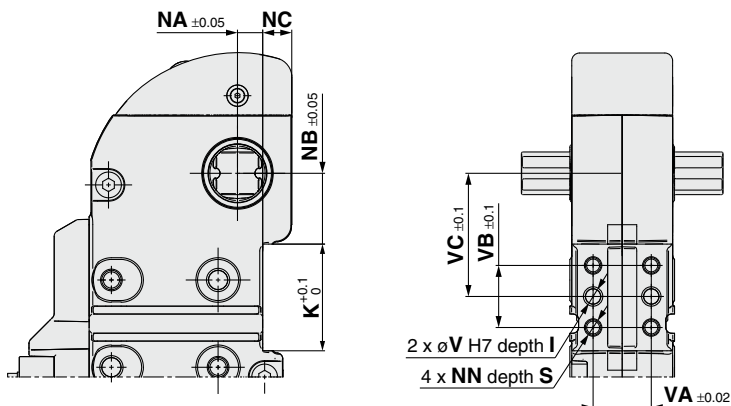

Bore size	I	K	NA	NB	NC	NN	S	V	VA	VB	VC
50	12	55	13	36.5	9.5	M8 x 1.25	11	8	30	32	63.5
63	15	55	13	36.5	15	M8 x 1.25	13	8	30	32	63.5

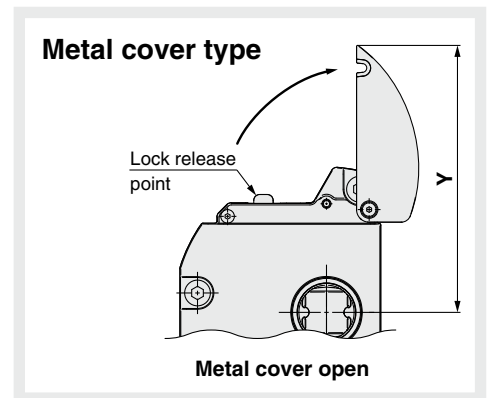

Bore size	I	K	NA	NB	NC	NN	S	V	VA	VB	VC
50	12	55	13	36.5	9.5	M8 x 1.25	11	8	30	32	63.5
63	15	55	13	36.5	15	M8 x 1.25	13	8	30	32	63.5

CKZM16
CKZT25/32
CKZT40
CKZ5T
CKZ3T
CKZT80
CKZ5N
CKZ3N
CKZ2N
CLJKQG
CLJKQP
CLJKQID
-X3256
CLJKQG32
CLJKU32
CLJKQG32
-X3036
Flow Control Equipment
Piping Equipment

**Dimensions: With Manual Handle**

\* Refer to the CKZ3N-X2742A (page 100) for dimensions other than those shown below.

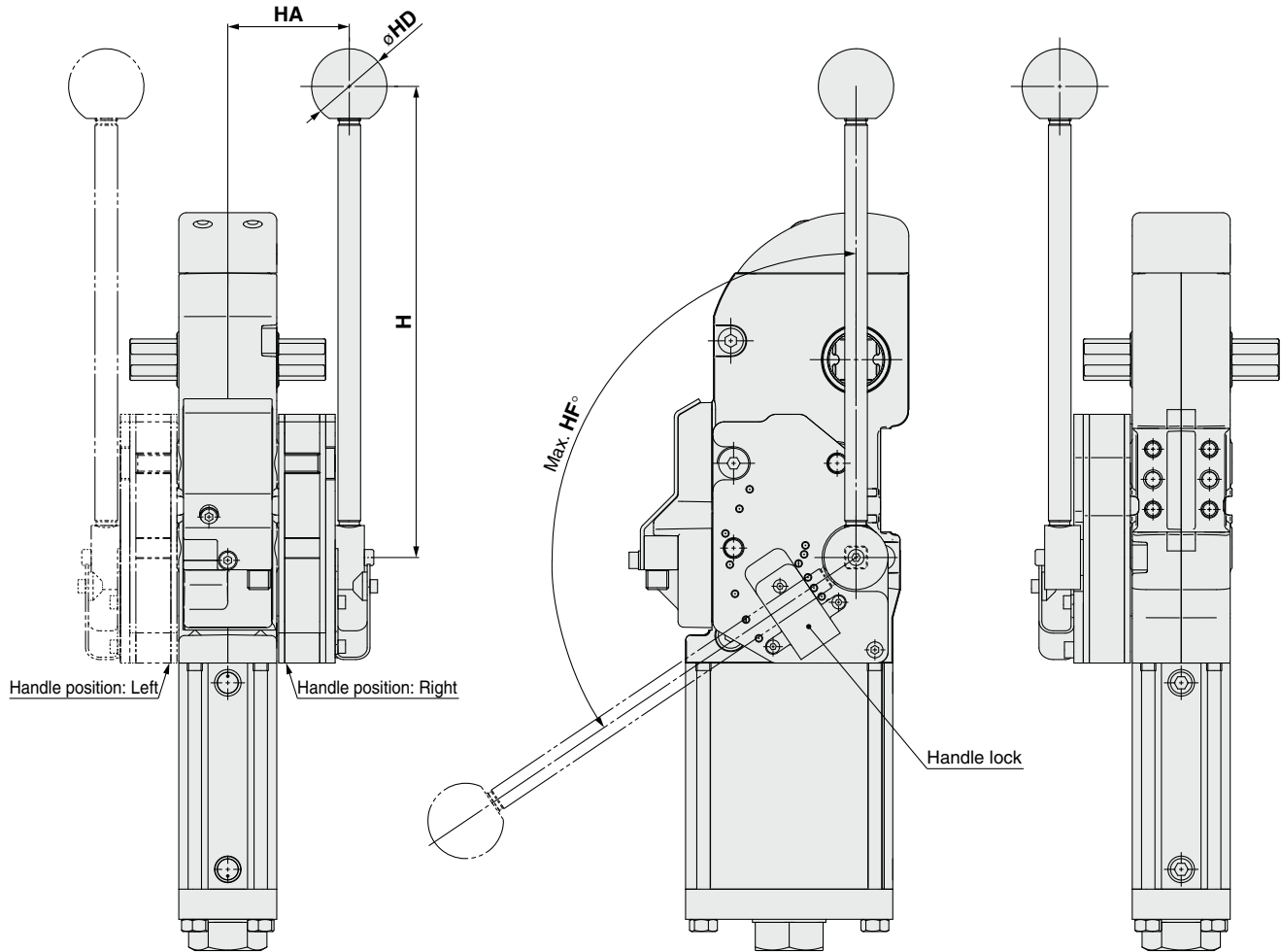

[mm]					
Bore size	Arm opening angle	H	HA	HD	HF°
50	15°	250	61.5	40	36
	30°				49
	45°				61
	60°				73
	75°				87
	90°				101
	105°				114
	120°				124
63	15°	250	64.5	40	41
	30°				55
	45°				68
	60°				81
	75°				94
	90°				107
	105°				117
	120°				124



**Clamp Arm Code List**

Bore size	SMC part no.	Clamp arm code	NAAMS code	Page
50	CKZ-50A001	A001	ACA201M	102
	CKZ-50A002	A002	ACA202M	
	CKZ-50A003	A003	ACA203M	
	CKZ-50A004	A004	ACA206M	
	CKZ-50A005	A005	ACA207M	
	CKZ-50A006	A006	ACA208M	
	CKZ-50A007	A007	ACA211M	103
	CKZ-50A008	A008	ACA212M	
	CKZ-50A009	A009	ACA213M	
	CKZ-50A010	A010	ACA216M	
	CKZ-50A011	A011	ACA217M	
	CKZ-50A012	A012	ACA218M	
	CKZ-50A013	A013	ACA221M	
	CKZ-50A014	A014	ACA222M	
	CKZ-50A015	A015	ACA223M	
	CKZ-50A016	A016	ACA226M	
	CKZ-50A017	A017	ACA227M	
	CKZ-50A018	A018	ACA228M	
	CKZ-50A019	A019	ACA236M	102
	CKZ-50A020	A020	ACA237M	
	CKZ-50A021	A021	ACA238M	
	CKZ-50A022	A022	ACA246M	
	CKZ-50A023	A023	ACA247M	103
	CKZ-50A024	A024	ACA248M	
	CKZ-50A025	A025	ACA256M	
	CKZ-50A026	A026	ACA257M	
	CKZ-50A027	A027	ACA258M	
63	CKZ-63A001	A001	ACA001M	104
	CKZ-63A002	A002	ACA002M	
	CKZ-63A003	A003	ACA003M	
	CKZ-63A004	A004	ACA004M	
	CKZ-63A005	A005	ACA005M	
	CKZ-63A006	A006	ACA006M	
	CKZ-63A007	A007	ACA007M	
	CKZ-63A008	A008	ACA008M	
	CKZ-63A009	A009	ACA009M	
	CKZ-63A010	A010	ACA010M	
	CKZ-63A011	A011	ACA011M	
	CKZ-63A012	A012	ACA012M	
	CKZ-63A013	A013	ACA013M	
	CKZ-63A014	A014	ACA014M	
	CKZ-63A015	A015	ACA015M	
	CKZ-63A016	A016	ACA016M	
	CKZ-63A017	A017	ACA017M	
	CKZ-63A018	A018	ACA018M	
	CKZ-63A019	A019	ACA019M	
	CKZ-63A020	A020	ACA020M	
	CKZ-63A021	A021	ACA021M	
	CKZ-63A022	A022	ACA022M	
	CKZ-63A023	A023	ACA023M	
	CKZ-63A024	A024	ACA024M	
	CKZ-63A025	A025	ACA025M	
	CKZ-63A026	A026	ACA026M	
	CKZ-63A027	A027	ACA027M	
CKZ-63A028	A028	ACA028M		
CKZ-63A029	A029	ACA029M		
CKZ-63A030	A030	ACA030M		
CKZ-63A031	A031	ACA031M		
CKZ-63A032	A032	ACA032M		
CKZ-63A033	A033	ACA033M		
CKZ-63A034	A034	ACA034M		
CKZ-63A035	A035	ACA035M		
CKZ-63A036	A036	ACA036M		
CKZ-63A037	A037	ACA037M		
CKZ-63A038	A038	ACA038M		
CKZ-63A039	A039	ACA039M		
CKZ-63A040	A040	ACA040M		
CKZ-63A041	A041	ACA041M		
CKZ-63A042	A042	ACA042M		
CKZ-63A043	A043	ACA043M		
CKZ-63A044	A044	ACA044M		
CKZ-63A045	A045	ACA045M		
CKZ-63A046	A046	ACA046M		
CKZ-63A047	A047	ACA047M		
CKZ-63A048	A048	ACA048M		

**Dimensions: Clamp Arm Bore Size 50**

**Straight: Plain**

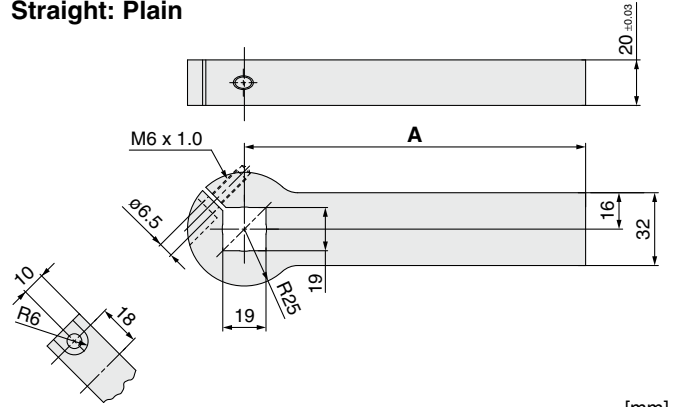

Model	NAAMS code	A	Weight [kg]
CKZ-50A001	ACA201M	90.0	0.6
CKZ-50A002	ACA202M	120.0	0.7
CKZ-50A003	ACA203M	150.0	0.9

**Straight: Machined**

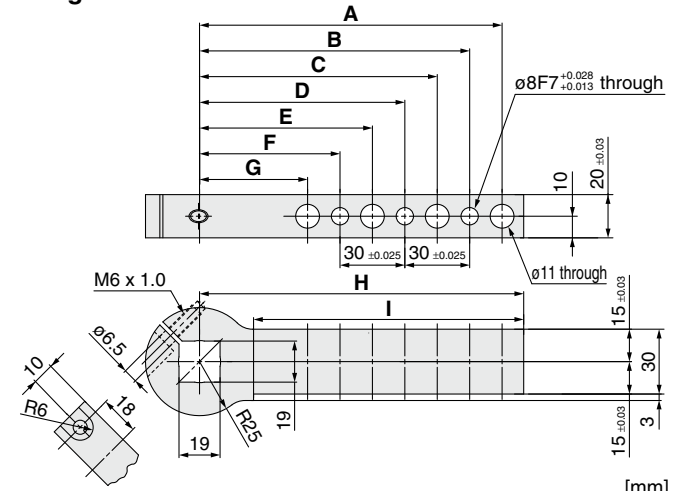

Model	NAAMS code	A	B	C	D	E	F	G	H	I	Weight [kg]
CKZ-50A004	ACA206M	80.0	65.0	50.0	—	—	—	—	90.0	65.0	0.5
CKZ-50A005	ACA207M	110.0	95.0	80.0	65.0	50.0	—	—	120.0	95.0	0.6
CKZ-50A006	ACA208M	140.0	125.0	110.0	95.0	80.0	65.0	50.0	150.0	125.0	0.7

**Straight: Machined**

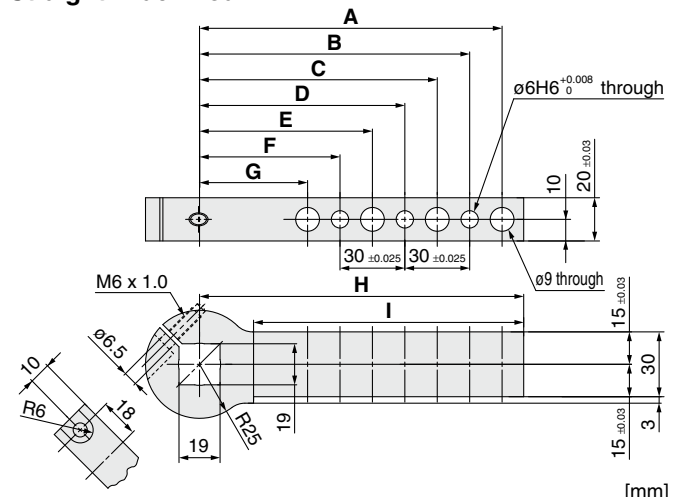

Model	NAAMS code	A	B	C	D	E	F	G	H	I	Weight [kg]
CKZ-50A019	ACA236M	80.0	65.0	50.0	—	—	—	—	90.0	65.0	0.5
CKZ-50A020	ACA237M	110.0	95.0	80.0	65.0	50.0	—	—	120.0	95.0	0.6
CKZ-50A021	ACA238M	140.0	125.0	110.0	95.0	80.0	65.0	50.0	150.0	125.0	0.7

- CKZM16
- CKZT25/32
- CKZT40
- CKZ5T
- CKZ3T
- CKZT80
- CKZ5N
- CKZ3N
- CKZ2N
- CLJKQG
- CLJKQP
- CLJKQID -X3256
- CLJKG32
- CLJKU32
- CLJKG32 -X3036
- Flow Control Equipment
- Piping Equipment

## Dimensions: Clamp Arm **Bore Size 50**

### 20 mm offset: Plain

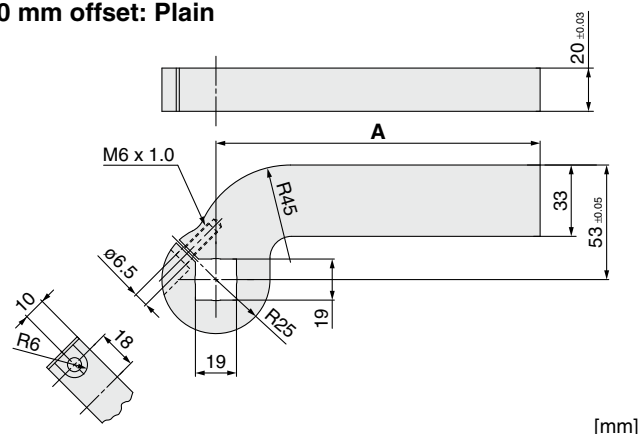

Model	NAAMS code	A	Weight [kg]
CKZ-50A007	ACA211M	90.0	0.7
CKZ-50A008	ACA212M	120.0	0.8
CKZ-50A009	ACA213M	150.0	1.0

### 45 mm offset: Plain

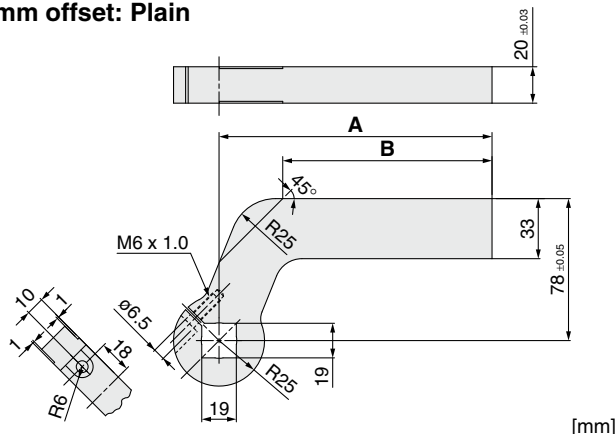

Model	NAAMS code	A	B	Weight [kg]
CKZ-50A013	ACA221M	90.0	55.0	0.8
CKZ-50A014	ACA222M	120.0	85.0	0.9
CKZ-50A015	ACA223M	150.0	115.0	1.1

### 25 mm offset: Machined

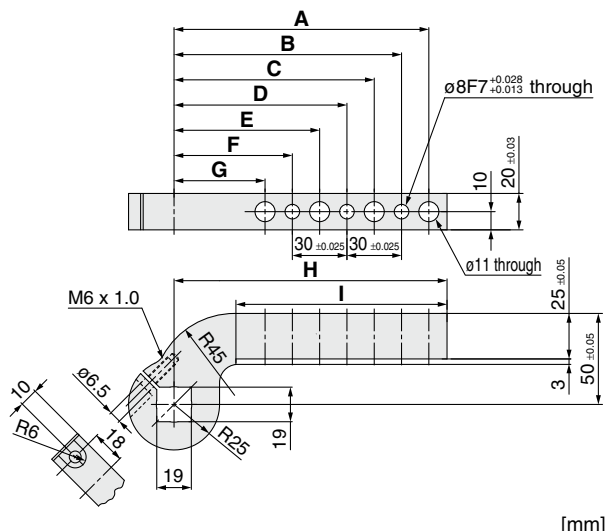

Model	NAAMS code	A	B	C	D	E	F	G	H	I	Weight [kg]
CKZ-50A010	ACA216M	80.0	65.0	50.0	—	—	—	—	90.0	56.0	0.5
CKZ-50A011	ACA217M	110.0	95.0	80.0	65.0	50.0	—	—	120.0	86.0	0.6
CKZ-50A012	ACA218M	140.0	125.0	110.0	95.0	80.0	65.0	50.0	150.0	116.0	0.7

### 50 mm offset: Machined

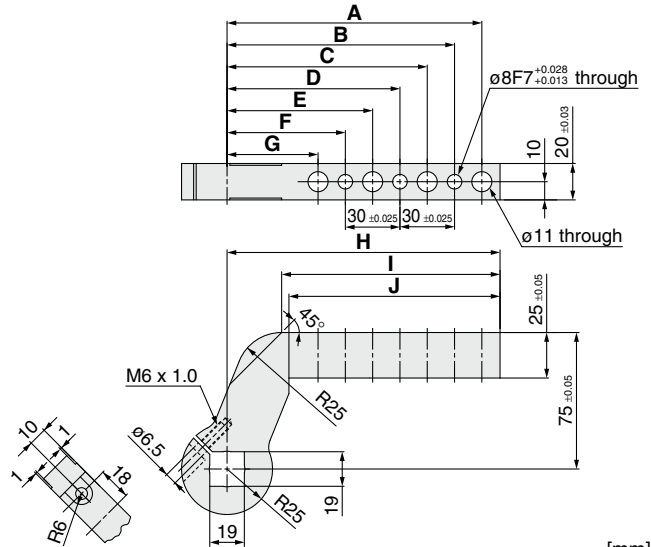

Model	NAAMS code	A	B	C	D	E	F	G	H	I	J	Weight [kg]
CKZ-50A016	ACA226M	80.0	65.0	50.0	—	—	—	—	90.0	60.0	56.0	0.6
CKZ-50A017	ACA227M	110.0	95.0	80.0	65.0	50.0	—	—	120.0	90.0	86.0	0.7
CKZ-50A018	ACA228M	140.0	125.0	110.0	95.0	80.0	65.0	50.0	150.0	120.0	116.0	0.8

### 25 mm offset: Machined

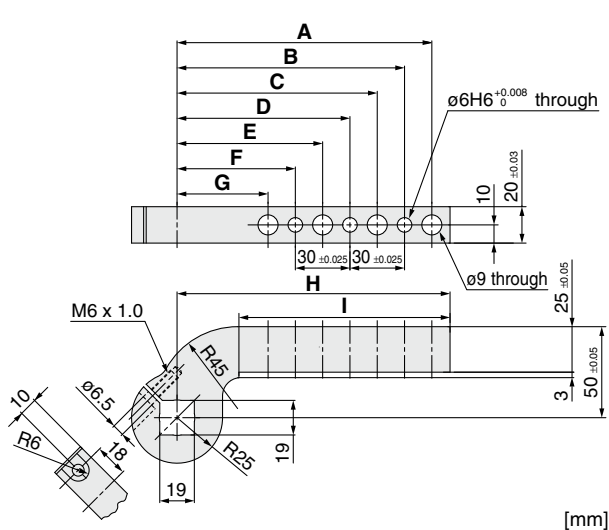

Model	NAAMS code	A	B	C	D	E	F	G	H	I	Weight [kg]
CKZ-50A022	ACA246M	80.0	65.0	50.0	—	—	—	—	90.0	56.0	0.5
CKZ-50A023	ACA247M	110.0	95.0	80.0	65.0	50.0	—	—	120.0	86.0	0.6
CKZ-50A024	ACA248M	140.0	125.0	110.0	95.0	80.0	65.0	50.0	150.0	116.0	0.7

### 50 mm offset: Machined

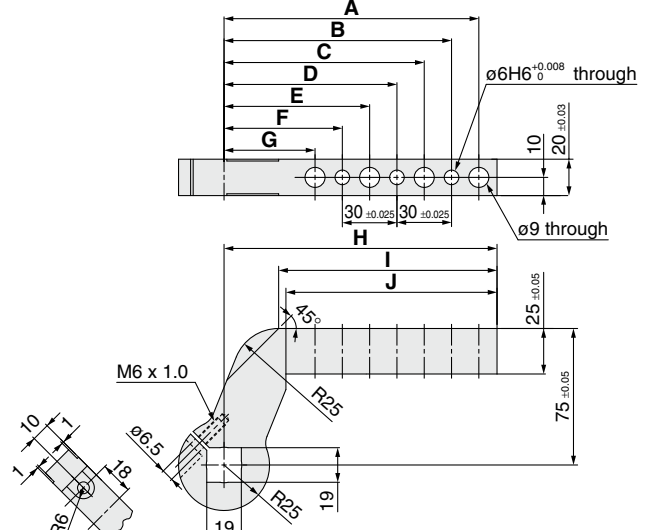

Model	NAAMS code	A	B	C	D	E	F	G	H	I	J	Weight [kg]
CKZ-50A025	ACA256M	80.0	65.0	50.0	—	—	—	—	90.0	60.0	56.0	0.6
CKZ-50A026	ACA257M	110.0	95.0	80.0	65.0	50.0	—	—	120.0	90.0	86.0	0.7
CKZ-50A027	ACA258M	140.0	125.0	110.0	95.0	80.0	65.0	50.0	150.0	120.0	116.0	0.8



**Dimensions: Clamp Arm Bore Size 63**

**Straight: Plain**

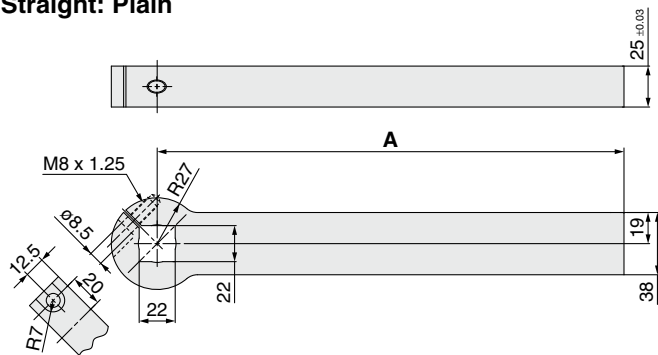

Model	NAAMS code	A	Weight [kg]
CKZ-63A001	ACA001M	135.0	1.2
CKZ-63A002	ACA002M	165.0	1.4
CKZ-63A003	ACA003M	195.0	1.6
CKZ-63A004	ACA004M	225.0	1.8
CKZ-63A005	ACA005M	255.0	2.1
CKZ-63A006	ACA006M	285.0	2.3

**20 mm offset: Plain**

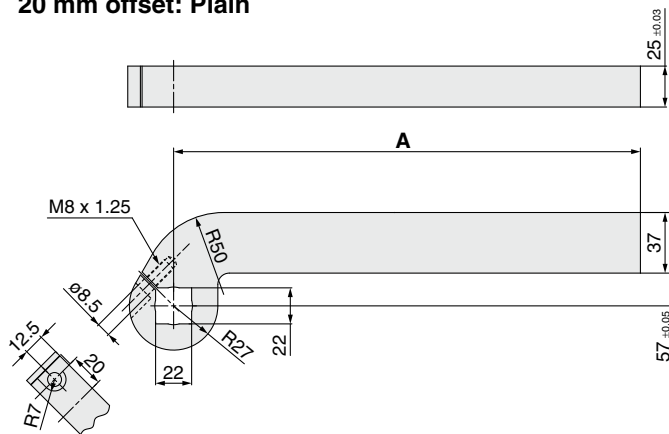

Model	NAAMS code	A	Weight [kg]
CKZ-63A013	ACA013M	135.0	1.4
CKZ-63A014	ACA014M	165.0	1.6
CKZ-63A015	ACA015M	195.0	1.8
CKZ-63A016	ACA016M	225.0	2.0
CKZ-63A017	ACA017M	255.0	2.2
CKZ-63A018	ACA018M	285.0	2.4

**Straight: Machined**

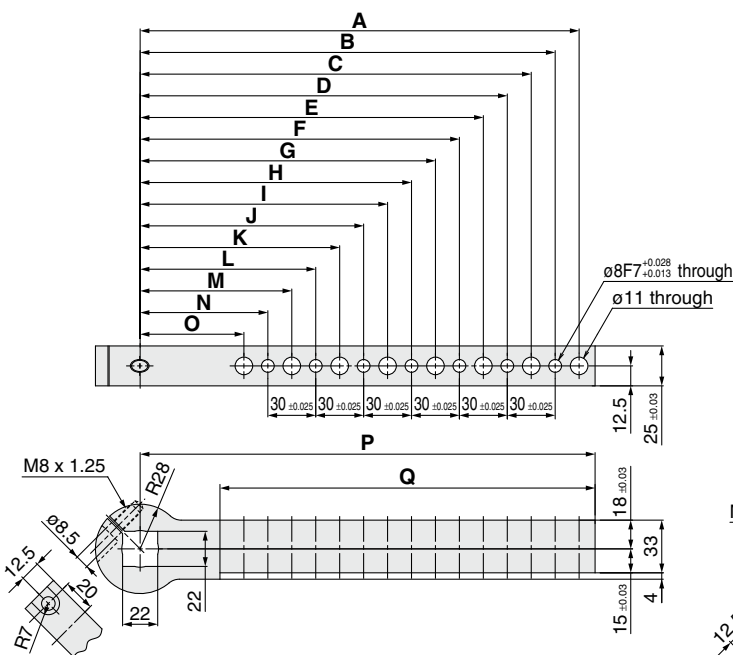

Model	NAAMS code	A	B	C	D	E	F	G	H	I	J	K	L	M	N	O	P	Q	Weight [kg]
CKZ-63A007	ACA007M	125.0	110.0	95.0	80.0	65.0	—	—	—	—	—	—	—	—	—	—	135.0	85.0	1.0
CKZ-63A008	ACA008M	155.0	140.0	125.0	110.0	95.0	80.0	65.0	—	—	—	—	—	—	—	—	165.0	115.0	1.2
CKZ-63A009	ACA009M	185.0	170.0	155.0	140.0	125.0	110.0	95.0	80.0	65.0	—	—	—	—	—	—	195.0	145.0	1.4
CKZ-63A010	ACA010M	215.0	200.0	185.0	170.0	155.0	140.0	125.0	110.0	95.0	80.0	65.0	—	—	—	—	225.0	175.0	1.5
CKZ-63A011	ACA011M	245.0	230.0	215.0	200.0	185.0	170.0	155.0	140.0	125.0	110.0	95.0	80.0	65.0	—	—	255.0	205.0	1.7
CKZ-63A012	ACA012M	275.0	260.0	245.0	230.0	215.0	200.0	185.0	170.0	155.0	140.0	125.0	110.0	95.0	80.0	65.0	285.0	235.0	1.9

**25 mm offset: Machined**

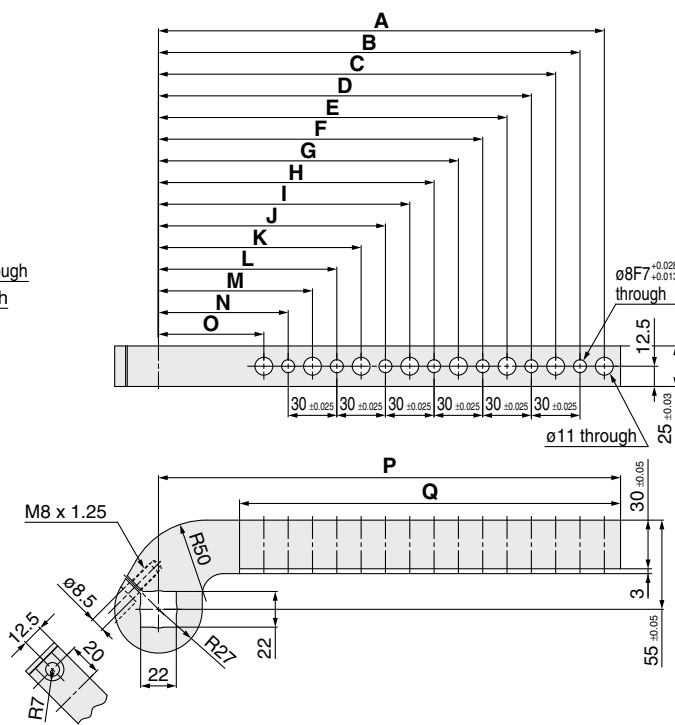

Model	NAAMS code	A	B	C	D	E	F	G	H	I	J	K	L	M	N	O	P	Q	Weight [kg]
CKZ-63A019	ACA019M	125.0	110.0	95.0	80.0	65.0	—	—	—	—	—	—	—	—	—	—	135.0	85.0	1.3
CKZ-63A020	ACA020M	155.0	140.0	125.0	110.0	95.0	80.0	65.0	—	—	—	—	—	—	—	—	165.0	115.0	1.5
CKZ-63A021	ACA021M	185.0	170.0	155.0	140.0	125.0	110.0	95.0	80.0	65.0	—	—	—	—	—	—	195.0	145.0	1.6
CKZ-63A022	ACA022M	215.0	200.0	185.0	170.0	155.0	140.0	125.0	110.0	95.0	80.0	65.0	—	—	—	—	225.0	175.0	1.7
CKZ-63A023	ACA023M	245.0	230.0	215.0	200.0	185.0	170.0	155.0	140.0	125.0	110.0	95.0	80.0	65.0	—	—	255.0	205.0	1.9
CKZ-63A024	ACA024M	275.0	260.0	245.0	230.0	215.0	200.0	185.0	170.0	155.0	140.0	125.0	110.0	95.0	80.0	65.0	285.0	235.0	2.1

- CKZM16
- CKZT25/32
- CKZT40
- CKZ5T
- CKZ3T
- CKZT80
- CKZ5N
- CKZ3N
- CKZ2N
- CL)KQG
- CL)KQP
- CL)KQD
- X3256
- CL)KQG32
- CL)KQJ32
- CL)KQG32
- X3036
- Flow Control Equipment
- Piping Equipment

**Dimensions: Clamp Arm Bore Size 63**

**65 mm offset: Plain**

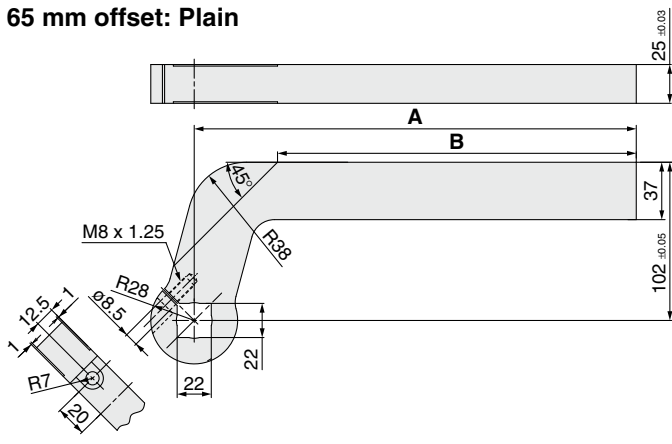

Model	NAAMS code	A	B	Weight [kg]
CKZ-63A025	ACA025M	135.0	81.3	1.7
CKZ-63A026	ACA026M	165.0	111.3	1.9
CKZ-63A027	ACA027M	195.0	141.3	2.1
CKZ-63A028	ACA028M	225.0	171.3	2.3
CKZ-63A029	ACA029M	255.0	201.3	2.5
CKZ-63A030	ACA030M	285.0	231.3	2.7

**115 mm offset: Plain**

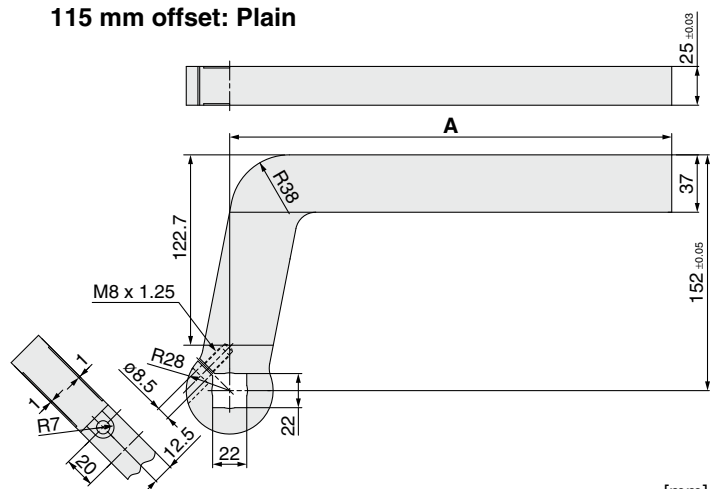

Model	NAAMS code	A	Weight [kg]
CKZ-63A037	ACA037M	135.0	2.1
CKZ-63A038	ACA038M	165.0	2.3
CKZ-63A039	ACA039M	195.0	2.5
CKZ-63A040	ACA040M	225.0	2.7
CKZ-63A041	ACA041M	255.0	2.9
CKZ-63A042	ACA042M	285.0	3.1

**70 mm offset: Machined**

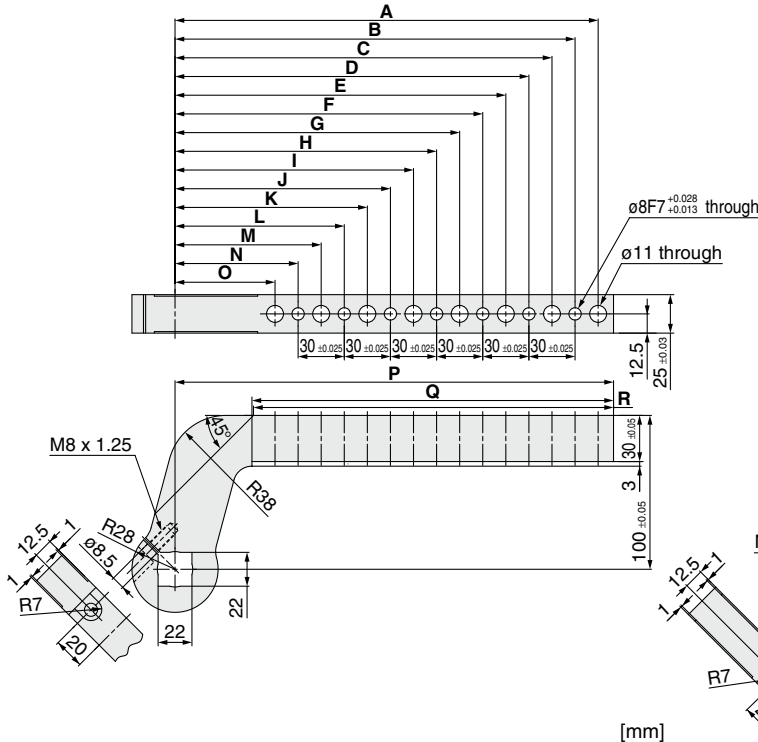

Model	NAAMS code	A	B	C	D	E	F	G	H	I	J	K	L	M	N	O	P	Q	R	Weight [kg]
CKZ-63A031	ACA031M	125.0	110.0	95.0	80.0	65.0	—	—	—	—	—	—	—	—	—	—	135.0	85.0	84.0	1.4
CKZ-63A032	ACA032M	155.0	140.0	125.0	110.0	95.0	80.0	65.0	—	—	—	—	—	—	—	—	165.0	115.0	114.0	1.6
CKZ-63A033	ACA033M	185.0	170.0	155.0	140.0	125.0	110.0	95.0	80.0	65.0	—	—	—	—	—	—	195.0	145.0	144.0	1.8
CKZ-63A034	ACA034M	215.0	200.0	185.0	170.0	155.0	140.0	125.0	110.0	95.0	80.0	—	—	—	—	—	225.0	175.0	174.0	1.9
CKZ-63A035	ACA035M	245.0	230.0	215.0	200.0	185.0	170.0	155.0	140.0	125.0	110.0	—	—	—	—	—	255.0	205.0	204.0	2.1
CKZ-63A036	ACA036M	275.0	260.0	245.0	230.0	215.0	200.0	185.0	170.0	155.0	140.0	—	—	—	—	—	285.0	235.0	234.0	2.3

**120 mm offset: Machined**

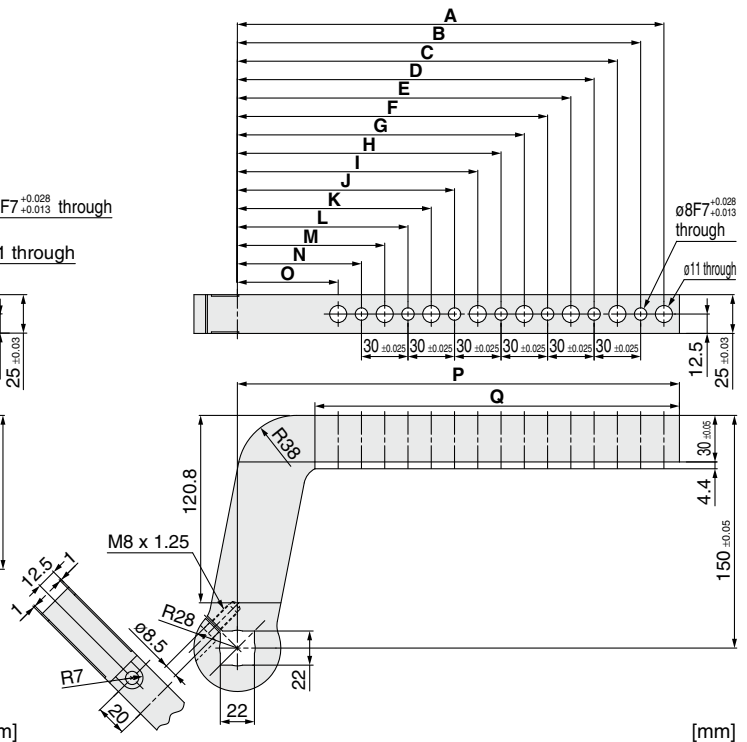

Model	NAAMS code	A	B	C	D	E	F	G	H	I	J	K	L	M	N	O	P	Q	Weight [kg]
CKZ-63A043	ACA043M	125.0	110.0	95.0	80.0	65.0	—	—	—	—	—	—	—	—	—	—	135.0	85.0	1.8
CKZ-63A044	ACA044M	155.0	140.0	125.0	110.0	95.0	80.0	65.0	—	—	—	—	—	—	—	—	165.0	115.0	2.0
CKZ-63A045	ACA045M	185.0	170.0	155.0	140.0	125.0	110.0	95.0	80.0	65.0	—	—	—	—	—	—	195.0	145.0	2.1
CKZ-63A046	ACA046M	215.0	200.0	185.0	170.0	155.0	140.0	125.0	110.0	95.0	80.0	—	—	—	—	—	225.0	175.0	2.3
CKZ-63A047	ACA047M	245.0	230.0	215.0	200.0	185.0	170.0	155.0	140.0	125.0	110.0	—	—	—	—	—	255.0	205.0	2.5
CKZ-63A048	ACA048M	275.0	260.0	245.0	230.0	215.0	200.0	185.0	170.0	155.0	140.0	—	—	—	—	—	285.0	235.0	2.6

# Model Selection

## Relation between arm length and clamping force

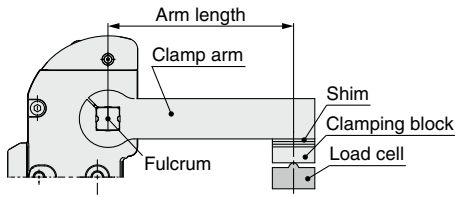

### Bore Size: 50

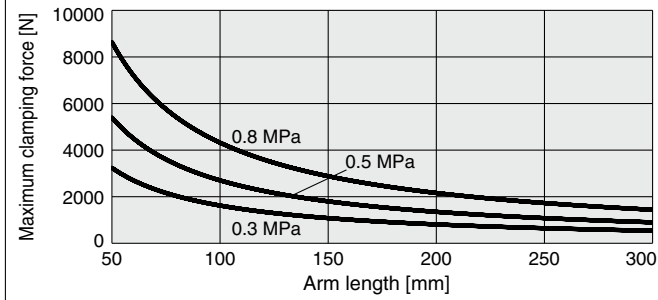

### Bore Size: 63

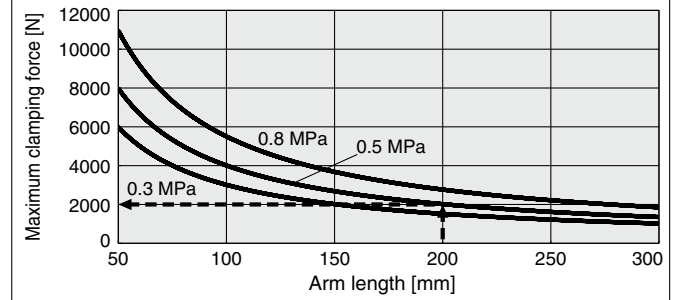

**Calculation example** Bore size: 63, Arm length: 200 mm, Operating pressure: 0.5 MPa

With an arm length of 200 mm and an operating pressure of 0.5 MPa, according to the graph, the maximum clamping force is 2000 N.

## Allowable arm length

### Allowable arm length

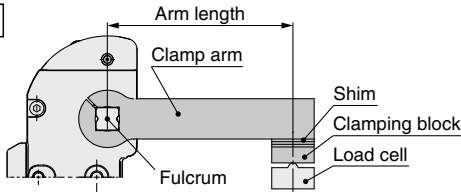

Bore size	Allowable arm length [mm]
50	300
63	300

## Allowable load mass

The allowable load mass changes depending on the arm opening angle. Be sure to use the product within the allowable values shown in the graphs below.  
\* The load indicates the total weight of the clamp arm and clamping block.  
\* When the operating time is 1 second

### Calculation procedure for allowable load mass

1. Calculate the distance L from the fulcrum to the load center of gravity.
2. Check the arm opening angle of the product.
3. Read the allowable load mass from the graph.

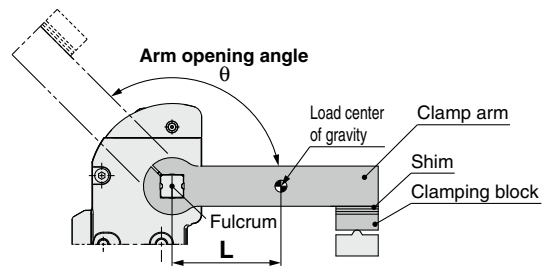

### Bore Size: 50

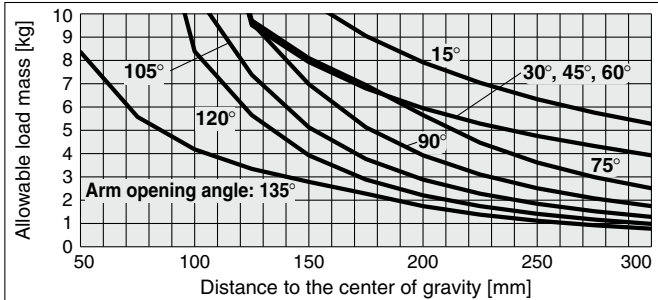

### Bore Size: 63

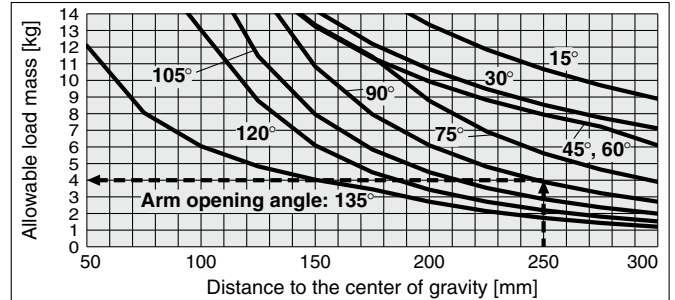

**Calculation example** Bore size: 63, Arm opening angle: 90°, Distance to the center of gravity L: 250 mm

With an arm opening angle of 90° and a 250 mm distance to the center of gravity, according to the graph, the maximum allowable load mass is 4.0 kg.

Power Clamp Cylinders  
CKZM16  
CKZT25/32  
CKZT40  
CKZ5T  
CKZ3T  
CKZT80  
CKZ5N  
CKZ3N  
CKZ2N  
Related Products  
C(L)KQG □  
C(L)KQP □  
C(L)KQ □  
C(L)KQ □  
-X3256  
C(L)KQG32  
C(L)KQ32  
C(L)KU32  
-X3036  
Flow Control Equipment  
Piping Equipment

# Setup Procedure

## Precautions

- 1) The tightening torque of the clamp arm is 12 to 15 N·m for  $\phi 50$  and 15 to 20 N·m for  $\phi 63$ . Refer to pages 102 to 105 for details on the clamp arm.
- 2) This product is designed to be used after being externally adjusted using a shim, and there is a mechanical difference of 0 to  $+0.5^\circ$  at the clamping end as shown in Figure 1.
- 3) Be sure to use a speed controller, and make adjustments according to the following conditions.

**Unclamping to clamping: 1 second or more**

**Clamping to unclamping: 1 second or more**

If excessive kinetic energy is applied, there is a possibility of damage.

- 4) When using a side guide:

Attach the side guide so that lateral loads, such as galling, etc., are not applied to the clamp arm.

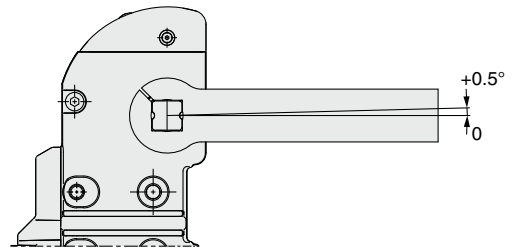
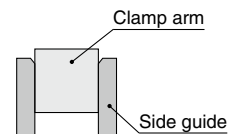
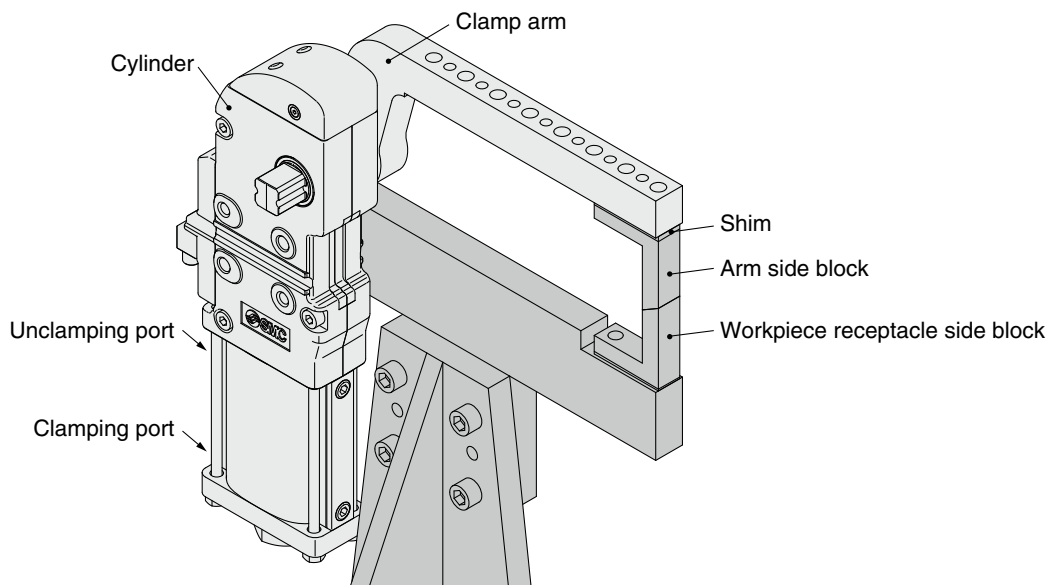

Figure 1



## Power clamp cylinder mounting and setup procedure

### <Ex. 1 When using clamping force only: When equipped with a workpiece receptacle>



### ■ Procedure

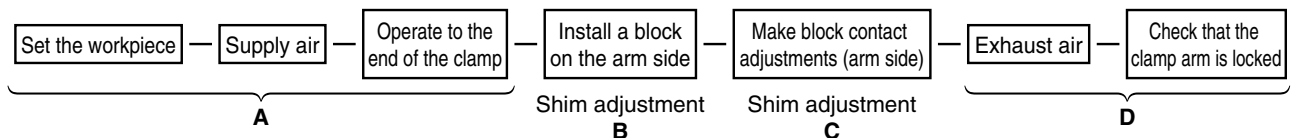

- A) Place the workpiece, supply air to the clamping port without attaching the block on the arm side, and operate the clamp arm to the end of the clamp.
- B) In the state of A), attach the arm side block, and adjust the shim so that there is a space of about 0 mm between the arm side block and the workpiece.  
During this step, theoretically, there is no clamping force pressing down on the workpiece.
- C) In order to generate a clamping force from the state described in step B), insert an additional shim.  
The thickness of the shim changes depending on the arm length and the operating pressure. Refer to page 109.  
Please note that the graph should only be used as a guide as there is a tolerance of about 10% in the clamp cylinder body.
- D) Exhaust the air while in the clamped state, and confirm that the clamp arm does not open.

**Power clamp cylinder mounting and setup procedure**

**<Ex. 2 When using a hard stop: When not equipped with a workpiece receptacle>**

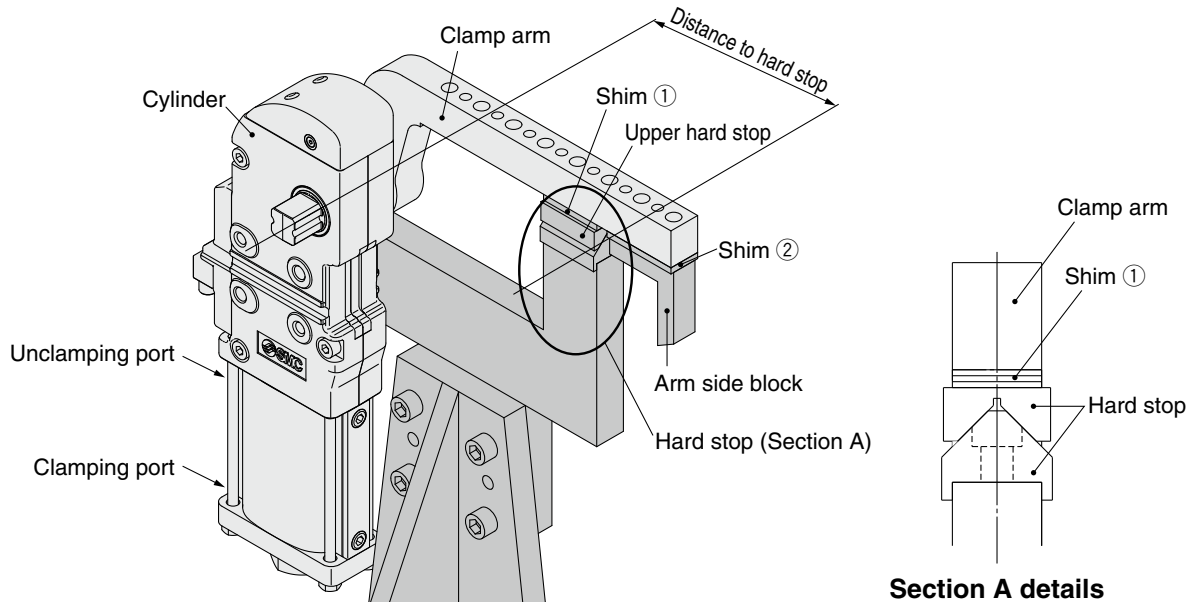

**Procedure**

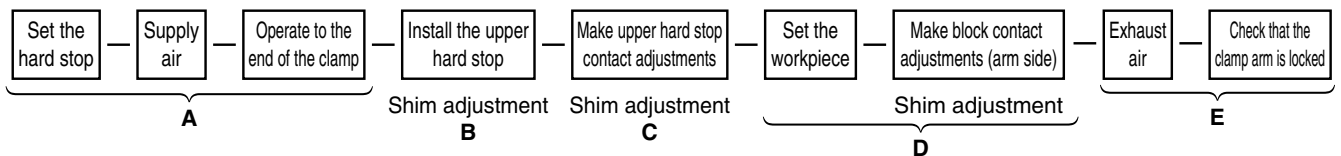

- A) Supply air to the clamping port without installing the upper hard stop, and operate the clamp arm to the end of the clamp.
- B) In the state of A), attach the upper hard stop and adjust shim ① so that there is a space of about 0 mm between the upper hard stop and the hard stop.  
During this step, theoretically, there is no clamping force applied to the hard stop.
- C) In order to generate a clamping force from the state described in step B), insert an additional shim ①.  
The thickness of the shim changes depending on the distance to the hard stop and the operating pressure. Refer to page 109, and consider the distance to the hard stop as the arm length.  
Please note that the graph should only be used as a guide as there is a tolerance of about 10% in the clamp cylinder body.
- D) In the state of C), adjust shim ② so that the arm side block contacts the workpiece.
- E) Exhaust the air while in the clamped state, and confirm that the clamp arm does not open.

CKZM16
CKZT25/32
CKZT40
CKZ5T
CKZ3T
CKZT80
CKZ5N
CKZ3N
CKZ2N
CL)KQG □
CL)KQP □
CL)KQ □
CL)KQ □
-X3256
CL)KQG32
CL)KU32
CL)KQG32
CL)KU32
-X3036
Flow Control Equipment
Piping Equipment

## Relation between shim thickness and clamping force

- \* Use this figure as a guide as there is a tolerance of about 10% in the clamp cylinder body.
- \* When a shim exceeding the peak clamping force position on the graph is inserted, the lock will not be activated when clamped. Insert a shim of the appropriate thickness.
- \*1 The arm length indicates the distance between the clamp arm shaft and the clamping position.

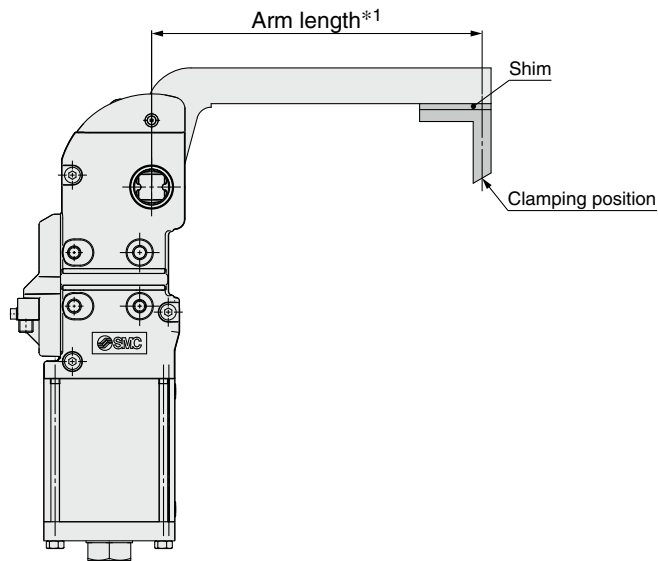

### Bore Size: 50

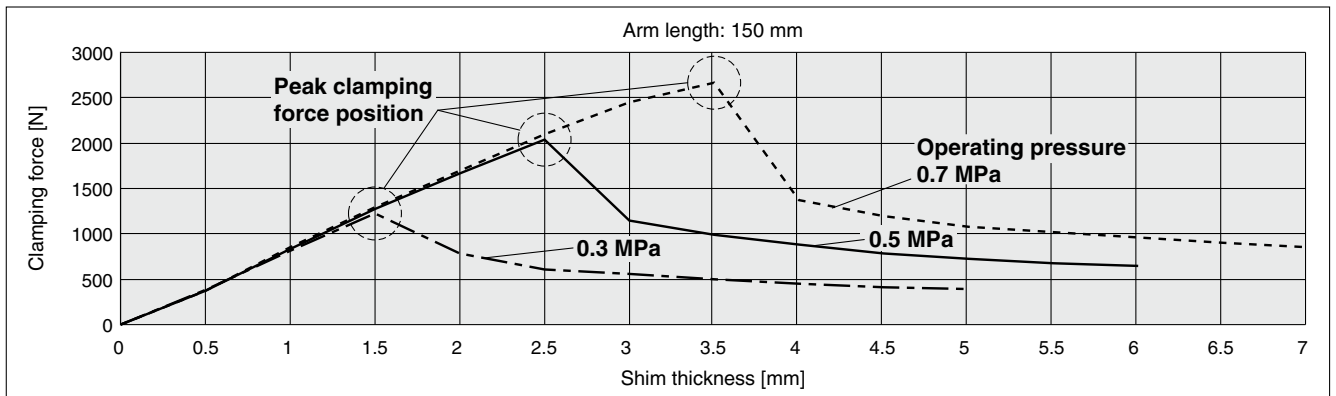

### Bore Size: 63

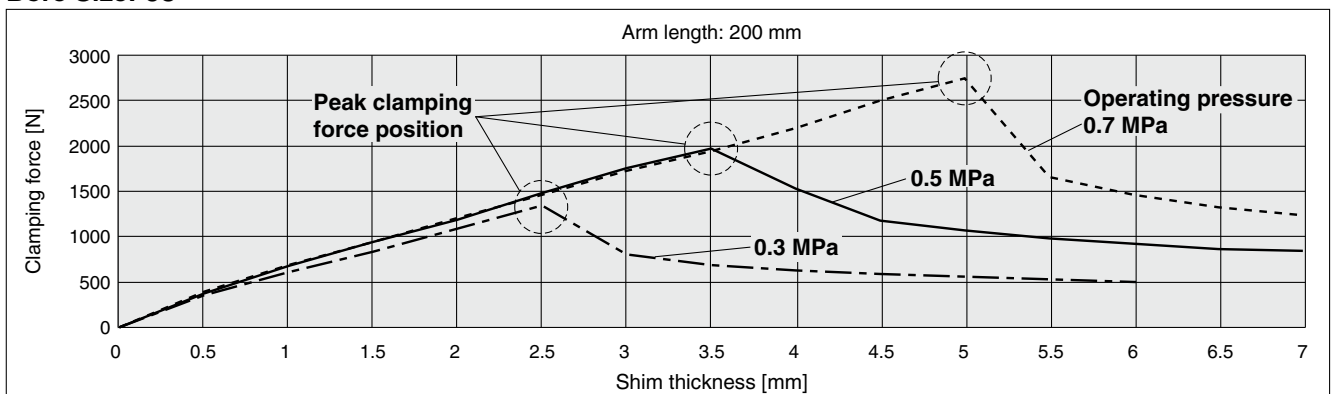



## To change the arm opening angle

**⚠ Caution** Be sure to confirm safety, and perform the work while the air is exhausted.

### 1 Procedure for changing the stopper bolt position

- 1) Remove the stopper bolt of the head cover, and replace with a stopper bolt for the desired angle using the tightening torque below. When tightening the stopper bolt, hold the head cover.  
Refer to "Replacement Parts" (page 99) for the part numbers of the applicable stopper bolts.

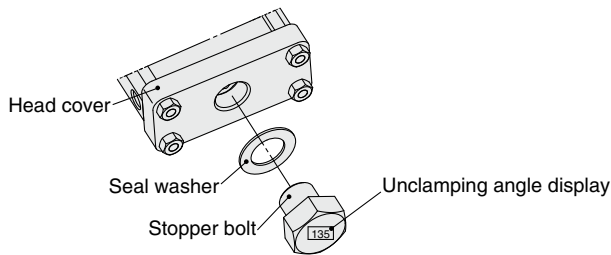

#### Stopper Bolt Tightening Torque

Bore size	Tightening torque [N·m]
50	45 to 65
63	85 to 115

### 2 Procedure for changing the switch position

- 1) Loosen the switch cassette mounting bolt, and remove the switch cassette.
- 2) Remove the switch on the unclamping side, and attach it in the position of the desired angle. Store the lead wire in the storage space.
- 3) Mount the switch cassette to the body, and tighten the switch cassette mounting bolt to the tightening torque shown below.  
Refer to "Replacement Parts" (page 99) for the part numbers of the switch cassette replacement parts.

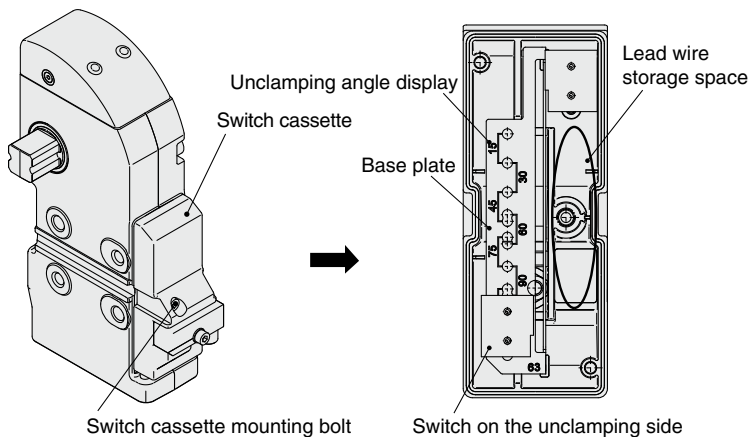

#### Switch Cassette Mounting Bolt Tightening Torque

Bore size	Tightening torque [N·m]
50	2.6 to 3.5
63	2.6 to 3.5

## Top cover replacement

**⚠ Caution** Be sure to confirm safety, and perform the work while the air is exhausted.

- 1) Mount the top cover to the clamp cylinder, then tighten it to the specified tightening torque below.
- 2) It is possible to change from a rubber cover type to a metal cover type.  
Refer to "Replacement Parts" (page 99) for the part numbers of the top cover replacement parts.

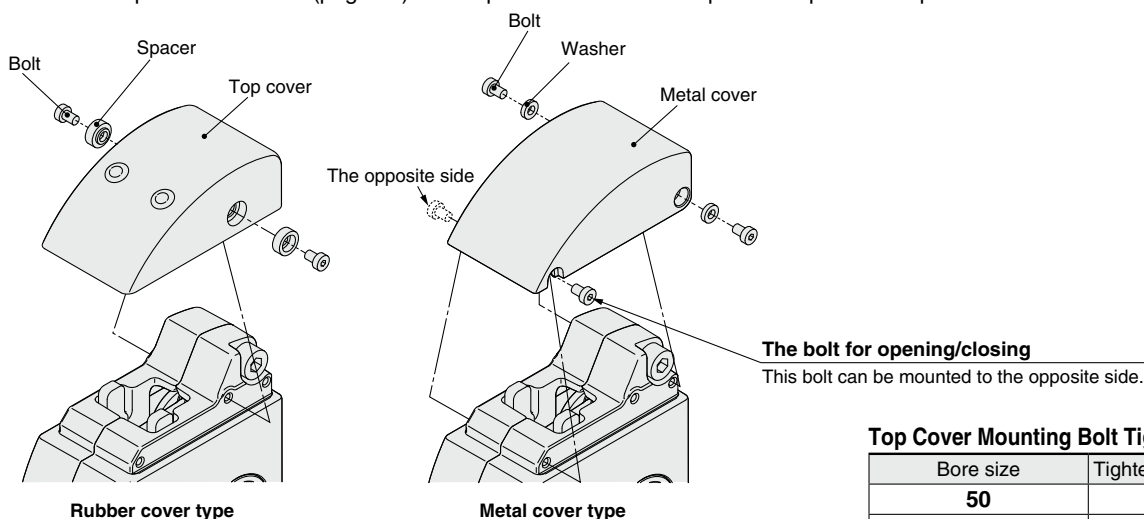

#### Top Cover Mounting Bolt Tightening Torque

Bore size	Tightening torque [N·m]
50	1.5 to 2.0
63	1.5 to 2.0

Power Clamp Cylinders  
CKZM16  
CKZT25/32  
CKZT40  
CKZ5T  
CKZ3T  
CKZT80  
CKZ5N  
CKZ3N  
CKZ2N

Related Products  
C(L)KQG□  
C(L)KQP□  
C(L)KQ□D  
-X3256  
C(L)KQG32  
C(L)KU32  
C(L)KQG32  
-X3036  
Flow Control  
Equipment  
Piping  
Equipment



## 1 Large Port Orifice Specification

Symbol  
**-X3090**

The operating time for arm opening angles of 15° to 90° can be set to 0.6 s.

### How to Order

**CKZ3N 63** - **120 R T** - **F** - **X3090**

**Bore size**

50	ø50 equivalent
63	ø63 equivalent

**Cylinder port**

Nil	NPT
TF	G
TP	Rc

**Arm opening angle**

Symbol	Arm opening angle
15	15°
30	30°
45	45°
60	60°
75	75°
90	90°
105	105°
120	120°
135	135°

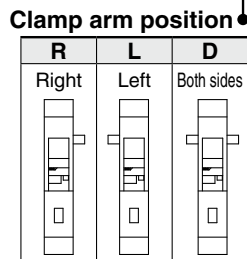

\* Proximity switch mounting surface viewed from the front

**Large port orifice specification**

**Top cover**

Nil	Rubber cover (Equivalent to UL94 Standard V0: Flame resistant)
M	Metal cover

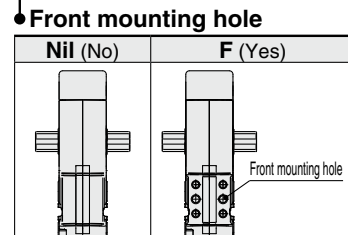

**With metal switch cassette cover**

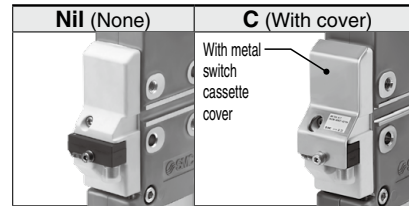

**Proximity switch**

T	TURCK
P	P&F
W	None

### Specifications

<b>Operating time</b>	Clamping: 0.6 s or more, Unclamping: 0.6 s or more*1
<b>Allowable load mass</b>	Refer to the graph below.
<b>Specifications other than the above</b>	Same as those of the standard type

\*1 The operating time for arm opening angles of 105°, 120°, and 135° is longer than 0.6 s.

**Dimensions: Same as those of the standard type**

### Allowable load mass

The allowable load mass changes depending on the arm opening angle. Be sure to use the product within the allowable values shown in the graphs below.

\* The load indicates the total weight of the clamp arm and clamping block.  
\* When the operating time is 0.6 s. When the operating time for arm opening angles of 105° to 135° is longer than 0.6 s.

#### Calculation procedure for allowable load mass

1. Calculate the distance L from the fulcrum to the load center of gravity.
2. Check the arm opening angle of the product.
3. Read the allowable load mass from the graph.

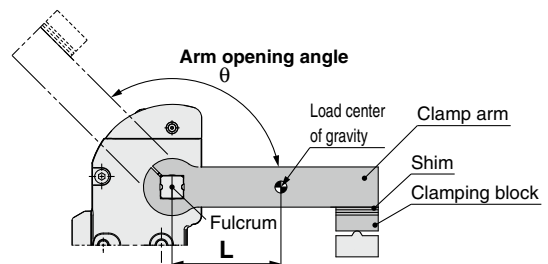

#### Bore Size: 50

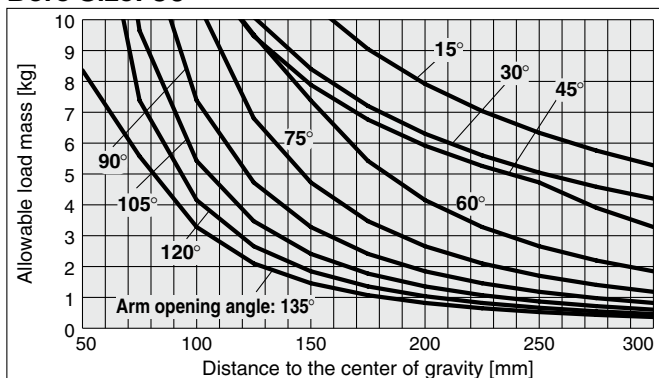

#### Bore Size: 63

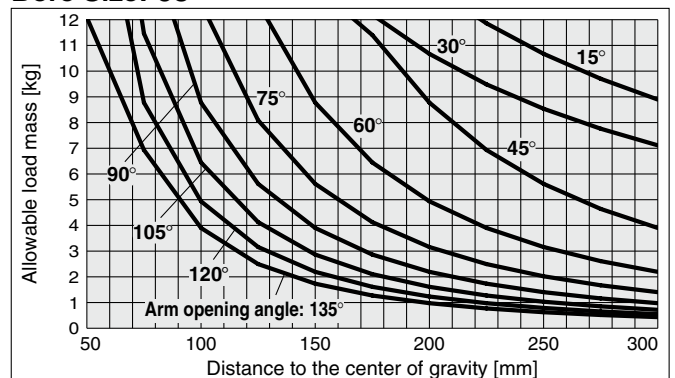



**CKZ3N** -X2742A  
-X2568□

# Specific Product Precautions

Be sure to read this before handling the products. Refer to page 179 for safety instructions. For actuator precautions, refer to the “Handling Precautions for SMC Products” and the “Operation Manual” on the SMC website: <https://www.smcworld.com>

## ⚠ Caution

### 1. Manual lock release

Be sure to confirm safety before manually releasing the lock, and only perform work while the air is exhausted. Otherwise, the clamp arm may operate unexpectedly.

- In the case of a rubber cover, the lock can be released easily by hitting the round tab on the cover with a plastic hammer.
- In the case of a metal cover, the lock can be released easily by opening the cover and hitting the tab of the knuckle joint with a plastic hammer.

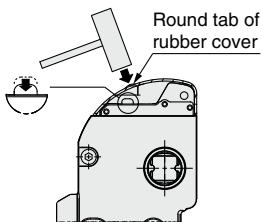

Rubber cover type

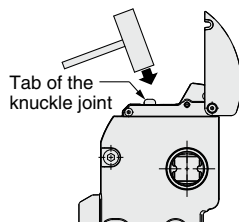

Metal cover type

- Provide enough space to perform a manual lock release.

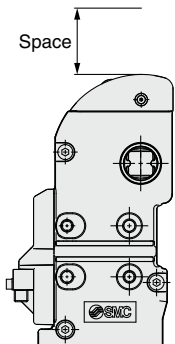

Rubber cover type

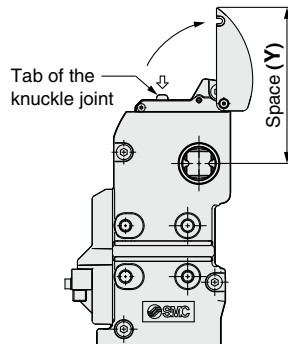

Metal cover type

[mm]	
Bore size	Y
50	132
63	138

### 2. Do not disassemble the power clamp cylinder.

The power clamp cylinder consists of a completely sealed structure in order to protect it from welding spatter. Do not disassemble, except for when replacing any of the replaceable parts, as this may cause the performance to deteriorate.

### 3. Clamp arm

The clamp arm may interfere with the cylinder body depending on the mounting method. Be sure to check for interference.

### 4. Proximity switch output

The switch output signal is output near the clamping end and the unclamping end respectively.

The switch output signal on the clamping side does not output the status where the power clamp cylinder is locked by the toggle mechanism.

## ⚠ Caution

### 5. With manual handle

Operating force of the handle should be 150 N or less. Excessive forces applied to the handle will lead to breakage or deformation.

### 6. Operating time and allowable load mass

Fast operation (short stroke times) or excessive loads will lead to the breakage or deformation of the product. It is recommended to install shock absorbers to reduce impact force in these instances.

Power Clamp Cylinders

CKZM16  
CKZT25/32  
CKZT40  
CKZ5T  
CKZ3T  
CKZT80  
CKZ5N  
CKZ3N  
CKZ2N

Related Products

C(L)KQG□  
C(L)KQP□  
C(L)KQ□D  
-X3256  
C(L)KQG32  
C(L)KU32  
C(L)KGG32  
-X3036  
Flow Control  
Equipment  
Piping  
Equipment