

Flame Resistant (Equivalent to UL-94 Standard V-0) FR One-touch Fittings **KR-W2 Series**

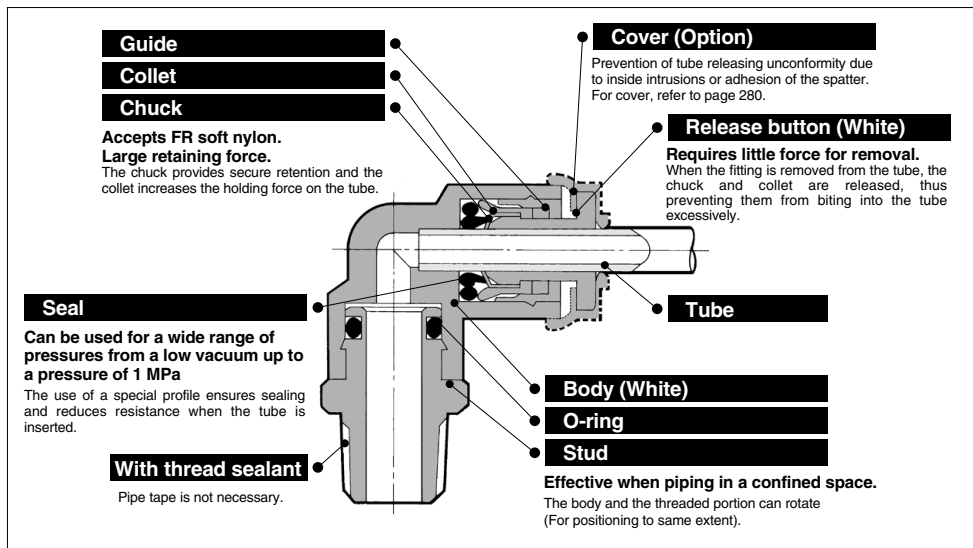

Made to Order

Symbol	Specifications
X2	Copper-free (With electroless nickel plated)

Suffix "X2" to the end of part number.
Example) KRH06-01SW2-X2

Applicable Tubing

Tubing material	FR double layer, FR soft nylon FR double layer polyurethane, FR three-layer polyurethane
Tubing O.D.	ø6, ø8, ø10, ø12

Specifications

Fluid		Air/Water (1, 2)
Operating pressure range (3)		-100 kPa to 1 MPa
Proof pressure (at 23°C)		3 MPa
Ambient and fluid temperature		-5 to 60°C (Water: 0 to 60°C) (No freezing)
Thread	Mounting section	JIS B 0203 (Taper thread for piping) JIS B 0205 (Metric coarse thread)
	Nut section	JIS B 0205 (Metric fine thread)
Seal on the threads		With sealant
Flame resistance		The external resin parts are equivalent to UL-94 standard V-0.

Note 1) The surge pressure must be under the maximum operating pressure.

Note 2) Deionized water is not recommended for use as it may affect the material used in the fittings.

In addition, it is known to degrade the water quality.

Note 3) Do not use the fittings with a leak tester or for vacuum retention because they are not guaranteed for zero leakage.

Principal Parts Material

Body	C3604, Flame resistant PBT (UL-94 standard V-0)
Stud	C3604 (Thread portion)
Chuck	Stainless steel 304
Guide	Stainless steel 304, Flame resistant PBT (UL-94 standard V-0)
Collet	POM
Release button	Flame resistant PBT (UL-94 standard V-0)
Seal, O-ring	NBR
Gasket	Stainless steel 304, NBR
Cover (Option)	Flame resistant PBT, Flame resistant CR (UL-94 standard V-0)

Model

Male connector

KRH-W2

P.276



Use to pipe in the same direction from female thread. Most general type.

Union elbow

KRL-W2

P.277



Use to connect tubes at right angles.

Plug-in reducer

KRR-W2

P.279



Use to size down One-touch fittings.

Straight union

KRH-W2

P.276



Use to connect tubes in the same direction.

Extended male elbow

KRW-W2

P.277



Basically, it is used together with male elbow. Different point is that it is used for fittings to avoid from interfering with each other by making the piping two-level.

Union "Y"

KRU-W2

P.278



Use to branch line in the same direction.

Male elbow

KRL-W2

P.276



Use to pipe at right angles to female thread. Most general type.

Extended plug-in elbow

KRW-W2

P.279



Use to change by 90° in a tube fetching direction from One-touch fittings. Can be used with the plug-in elbow for three-dimensional pipe arrangement.

Plug-in "Y"

KRU-W2

P.278



Use to branch line in the same direction from One-touch fittings.

45° male elbow

KRK-W2

P.276



Use to pipe in 45° angle direction from female thread. Model in-between of male connector and male elbow.

Male branch tee

KRT-W2

P.277



Use to branch line from female thread in both 90° directions.

Branch

KRU-W2

P.278



Use to branch line in the same direction from female thread.

Universal male elbow

KRV-W2

P.277



Universal male elbow allows thread connection by using a socket wrench for confined spaces.

Union tee

KRT-W2

P.277



Use to connect tubes in both 90° directions.

Bulkhead union

KRE-W2

P.279



Use to connect tubes through a panel.

Plug-in elbow

KRL-W2

P.279



Use to change by 90° in a tube fetching direction from One-touch fittings.

Male run tee

KRY-W2

P.278



Use to branch line in the same direction from female thread and in 90° direction.

Bulkhead Connector

KRE-W2

P.279



Use to connect male thread and tube through a panel.

Spatter cover

KR

P.280



Prevention of tube releasing unconformity due to an inside intrusion or adhesion of the spatter.

Spatter cover

KR-□C1

P.280



Prevention of tube releasing unconformity due to an inside intrusion or adhesion of the spatter.

Plug

KRP

P.280



Use to plug unused One-touch fittings.

KQ2

KQG2

**KS
KX**

KM

KF

M

**H/DL
L/LL**

KC

KK

KK130

DM

KDM

KB

KR

KA

KQG2

KG

KFG2

MS

KKA

KP

LQ

MQR

T

IDK

KR-W2 Series

Dimensions

Male Connector: KRH-W2



Applicable tubing O.D. (mm)	Connection thread M, R	Model	H (width across flats)	L	A ^ø	M	Effective area (mm ²)		Weight (g)
							FR double layer	FR soft nylon	
6	M5 x 0.8	KRH06-M5W2	10	23.3	19.8	17	4	4	6
	1/8	KRH06-01SW2	12	21.6	18.5				16
	1/4	KRH06-02SW2	14	22.5	17				14
	3/8	KRH06-03SW2	17	20.9	15.5				27
8	1/8	KRH08-01SW2	14	27.1	24	18.5	26.1	18.0	21
	1/4	KRH08-02SW2							19
	3/8	KRH08-03SW2							26
	1/2	KRH10-01SW2							29.1
10	1/4	KRH10-02SW2	17	33	27.5	21	41.5	29.5	30
	3/8	KRH10-03SW2							27.9
	1/2	KRH10-04SW2							22
	3/4	KRH12-02SW2							34
12	1/4	KRH12-02SW2	19	28.9	23.5	22	58.3	46.1	42
	3/8	KRH12-03SW2							34
	1/2	KRH12-04SW2							22
	3/4	KRH12-04SW2							22

* Reference dimensions after R thread installation.

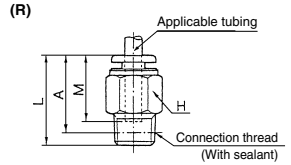
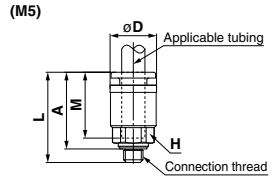

Straight Union: KRH-W2



Applicable tubing O.D. (mm)	Model	øD	L	M	Effective area (mm ²)		Weight (g)
					FR double layer	FR soft nylon	
6	KRH06-00W2	12.8	34.5	17	10.4	5.6	4
8	KRH08-00W2	15.2	38.5	18.5	26.1	18.0	6
10	KRH10-00W2	18.5	42.5	21	41.5	29.5	11
12	KRH12-00W2	20.9	44.5	22	58.3	46.1	14

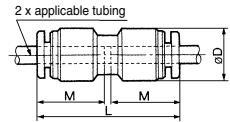

Male Elbow: KRL-W2



Applicable tubing O.D. (mm)	Connection thread M, R	Model	H (width across flats)	øD1	øD2	L1	L2	A ^ø	M	Effective area (mm ²)		Weight (g)			
										FR double layer	FR soft nylon				
6	M5 x 0.8	KRL06-M5W2	8	12.8	8	20.5	15.8	18.7	17	3.5	3.5	5			
	1/8	KRL06-01SW2	10									22.1	25.5	12	
	1/4	KRL06-02SW2	14									26.5	27.5	22	
	3/8	KRL06-03SW2	17									27.9	29	33	
8	1/8	KRL08-01SW2	12	15.2	12	23	28	30	18.5	21.6	14.9	21			
	1/4	KRL08-02SW2	14									29.4	31.5	35	
	3/8	KRL08-03SW2	17									26.1	32	25	
	1/2	KRL10-01SW2	17									29.5	33	26	
10	1/4	KRL10-02SW2	22	18.5	17	26.5	30.9	34.5	21	35.2	25.0	36			
	3/8	KRL10-03SW2										35.1	37	63	
	1/2	KRL12-02SW2										22	30.5	35.5	28
	3/4	KRL12-03SW2										17	31.9	37	38
12	1/2	KRL12-04SW2	22	20.9	17	28.5	36.1	39.5	22	50.2	39.7	65			
	3/4	KRL12-03SW2										17	36.1	39.5	65

* Reference dimensions after R thread installation.

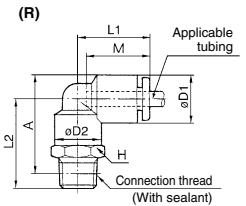
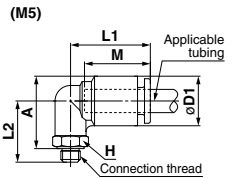

45° Male Elbow: KRK-W2



Applicable tubing O.D. (mm)	Connection thread R	Model	H (width across flats)	øD1	øD2	L1	L2	A ^ø	M	Effective area (mm ²)		Weight (g)			
										FR double layer	FR soft nylon				
6	1/8	KRK06-01SW2	10	12.8	10	18	19.6	33	17	6.9	3.4	12			
	1/4	KRK06-02SW2	14									24	35	30	
	3/8	KRK06-03SW2	17									25.4	36.5	33	
	1/2	KRK08-01SW2	12									21.1	37	13	
8	1/4	KRK08-02SW2	14	15.2	12	20.5	25.5	39	18.5	19.7	21	21			
	3/8	KRK08-03SW2	17									26.9	41	35	
	1/2	KRK10-01SW2	17									24	23.1	42	25
	3/4	KRK10-02SW2	17									26.5	43.5	26	
10	1/4	KRK10-03SW2	22	18.5	17	24	27.9	45	21	30.9	23.2	36			
	3/8	KRK10-04SW2										22	32.1	47.5	63
	1/2	KRK12-02SW2										17	27	45.5	28
	3/4	KRK12-03SW2										17	28.4	47.5	38
12	1/2	KRK12-04SW2	22	20.9	17	25	32.6	49.5	22	44.5	35.1	65			
	3/4	KRK12-03SW2										17	32.6	49.5	65

* Reference dimensions after R thread installation.

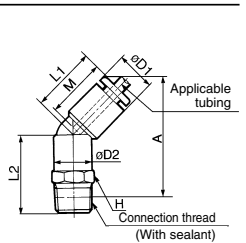

Universal Male Elbow: KRV-W2



Applicable tubing O.D. (mm)	Connection thread R	Model	H (width across flats)	øD1	øD2	L1	L2	L3	A*	M	Effective area (mm ²)		Weight (g)						
											FR double layer	FR soft nylon							
6	1/8	KRV06-01SW2	8	12.8	13.4	24	13.6	25.6	22.5	17	5.9	2.9	15						
	1/4	KRV06-02SW2	10										15.4	23.5	18	30.5	25	26	
	3/8	KRV06-03SW2	12										17.6	28.5	14.6	27.6	24.5	24	
8	1/8	KRV08-01SW2	12	15.2	17.6	28.5	18	31	25.5	18.5	16	11.2	30						
	1/4	KRV08-02SW2											14	20.6	27.5	19.4	35.4	30	47
	3/8	KRV08-03SW2											14	19	35	29.5	19.4	35.4	30
10	1/4	KRV10-02SW2	14	18.5	20.6	31	19	35	32	21	27	20.3	49						
	3/8	KRV10-03SW2											17	20.9	37.4	24.1	40.6	33.5	63
	1/2	KRV10-04SW2											17	20.9	37.4	24.1	40.6	33.5	80

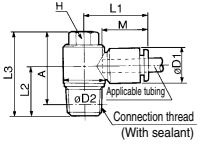

* Reference dimensions after R thread installation.

Union Elbow: KRL-W2



Applicable tubing O.D. (mm)	Model	øD	L	Q	M	Effective area (mm ²)		Weight (g)
						FR double layer	FR soft nylon	
6	KRL06-00W2	12.8	20	5.3	17	9.0	4.2	6
8	KRL08-00W2	15.2	23	6	18.5	21.6	14.9	10
10	KRL10-00W2	18.5	26.5	6.8	21	35.2	25.0	17
12	KRL12-00W2	20.9	28.5	7.5	22	50.2	39.7	21

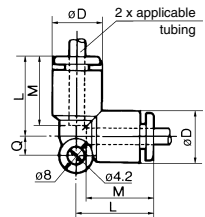

Extended Male Elbow: KRW-W2



Applicable tubing O.D. (mm)	Connection thread R	Model	H (width across flats)	øD1	øD2	L1	L2	A*	M	Effective area (mm ²)		Weight (g)				
										FR double layer	FR soft nylon					
6	1/8	KRW06-01SW2	10	12.8	10	20	39.1	42.5	17	8.6	4.0	26				
	1/4	KRW06-02SW2	14									45.5	46.5	46.9	48	41
	3/8	KRW06-03SW2	17									46.9	48	42.6	47	67
8	1/8	KRW08-01SW2	12	15.2	12	23	49	51	18.5	20.5	14.2	47				
	1/4	KRW08-02SW2	14									50.4	52.5	56	59.5	74
	3/8	KRW08-03SW2	17									56	59.5	57.4	61	66
10	1/4	KRW10-02SW2	17	18.5	17	26.5	56	59.5	21	33.5	23.8	76				
	3/8	KRW10-03SW2	22									64.1	66	57	62	145
	1/2	KRW10-04SW2	22									64.1	66	57	62	68
12	1/4	KRW12-02SW2	17	20.9	17	28.5	58.4	63.5	22	47.7	37.7	147				
	3/8	KRW12-03SW2	22									65.1	68.5	65.1	68.5	178
	1/2	KRW12-04SW2	22									65.1	68.5	65.1	68.5	147

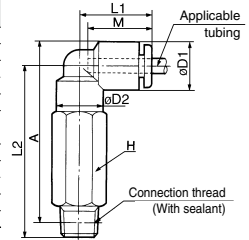

* Reference dimensions after R thread installation.

Union Tee: KRT-W2



Applicable tubing O.D. (mm)	Model	øD	L	Q	M	Effective area (mm ²)		Weight (g)
						FR double layer	FR soft nylon	
6	KRT06-00W2	12.8	20	5.3	17	10.6	6.4	10
8	KRT08-00W2	15.2	23	6	18.5	25.6	17.7	15
10	KRT10-00W2	18.5	26.5	6.8	21	40	28.4	25
12	KRT12-00W2	20.9	28.5	7.5	22	57.4	45.4	29

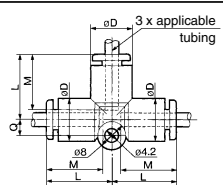

Male Branch Tee: KRT-W2



Applicable tubing O.D. (mm)	Connection thread R	Model	H (width across flats)	øD1	øD2	L1	L2	A*	M	Effective area (mm ²)		Weight (g)				
										FR double layer	FR soft nylon					
6	1/8	KRT06-01SW2	10	12.8	10	20	22.1	25.5	17	11.0	6.0	12				
	1/4	KRT06-02SW2	14									26.5	27.5	27.9	29	30
	3/8	KRT06-03SW2	17									27.9	29	23.6	28	22
8	1/8	KRT08-01SW2	12	15.2	12	23	28	30	18.5	26.3	18.2	22				
	1/4	KRT08-02SW2	14									29.4	31.5	26.1	32	36
	3/8	KRT08-03SW2	17									26.1	32	29.5	33	31
10	1/4	KRT10-02SW2	17	18.5	17	26.5	30.9	34.5	21	40.8	29.0	39				
	3/8	KRT10-03SW2	22									35.1	37	35.1	37	66
	1/2	KRT10-04SW2	22									30.5	35.5	31.9	37	31
12	1/4	KRT12-02SW2	17	20.9	17	28.5	36.1	39.5	22	57.2	45.2	41				
	3/8	KRT12-03SW2	22									36.1	39.5	36.1	39.5	68
	1/2	KRT12-04SW2	22									36.1	39.5	36.1	39.5	68

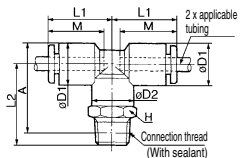

* Reference dimensions after R thread installation.

KQ2

KQB2

KS
KX

KM

KF

M

H/DL
L/LL

KC

KK

KK130

DM

KDM

KB

KR

KA

KQG2

KG

KFG2

MS

KKA

KP

LQ

MQR

T

IDK

KR-W2 Series

Male Run Tee: KRY-W2



Applicable tubing O.D. (mm)	Connection thread R	Model	H (width across flats)	øD1	øD2	L1	L2	A *	M	Effective area (mm ²)		Weight (g)
										FR double layer	FR soft nylon	
6	1/8	KRY06-01SW2	10	12.8	10	20	22.1	39	17	10.6	6.4	12
	1/4	KRY06-02SW2	14				26.5	41				20
	3/8	KRY06-03SW2	17				27.9	43.5				34
8	1/8	KRY08-01SW2	12	15.2	12	23	23.6	43.5	18.5	25.6	17.7	22
	1/4	KRY08-02SW2	14				28	45.5				36
	3/8	KRY08-03SW2	17				29.4	47				31
10	1/8	KRY10-01SW2	17	18.5	17	26.5	26.1	49.5	21	40.0	28.4	29
	1/4	KRY10-02SW2					29.5	50.5				39
	3/8	KRY10-03SW2					30.9	52				31
12	1/4	KRY12-02SW2	22	20.9	17	28.5	35.1	54.5	22	57.4	45.4	41
	3/8	KRY12-03SW2	30.5				53.5	48				
	1/2	KRY12-04SW2	36.1				57.5	61				

* Reference dimensions after R thread installation.

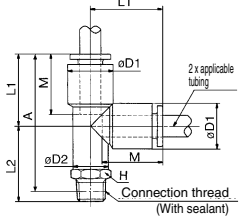

Branch: KRU-W2



Applicable tubing O.D. (mm)	Connection thread R	Model	H (width across flats)	øD	L	P	A *	M	Effective area (mm ²)		Weight (g)	
									FR double layer	FR soft nylon		
6	1/8	KRU06-01SW2	13	12.8	44.6	12.8	41.5	17	10.4	4.2	12	
	1/4	KRU06-02SW2	14		48.5		43					22
	3/8	KRU06-03SW2	17		49.9		44.5					35
8	1/8	KRU08-01SW2	17	15.2	51.6	15.2	48.5	18.5	25.6	17.7	24	
	1/4	KRU08-02SW2			55.4		50					36
	3/8	KRU08-03SW2			60.5		55					30
10	1/4	KRU10-02SW2	19	18.5	60.9	18.5	55.5	21	40	28.4	40	
	3/8	KRU10-03SW2	64.1		57		65					
	1/2	KRU10-04SW2	67.6		58.5		32					
12	1/4	KRU12-02SW2	22	20.9	64.4	20.9	59	22	57.4	45.4	40	
	3/8	KRU12-03SW2	67.6		60.5		40					
	1/2	KRU12-04SW2	67.6		60.5		65					

* Reference dimensions after R thread installation.

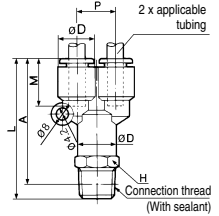

Union "Y": KRU-W2



Applicable tubing O.D. (mm)	Model	øD	L1	L2	P	Q	M	Effective area (mm ²)		Weight (g)
								FR double layer	FR soft nylon	
6	KRU06-00W2	12.8	37	20	12.8	11.7	17	10.4	4.2	10
8	KRU08-00W2	15.2	42.5	24.5	15.2	13.7	18.5	25.6	17.7	12
10	KRU10-00W2	18.5	48	27.5	18.5	16.1	21	40	28.4	16
12	KRU12-00W2	20.9	51	30	20.9	18.1	22	57.4	45.4	23

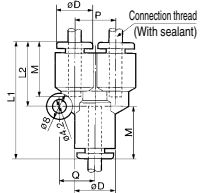

Plug-in "Y": KRU-W2



Applicable tubing O.D. (mm)	Applicable fitting size ød	Model	øD	L1	L2	P	Q	A	M	Effective area (mm ²)		Weight (g)
										FR double layer	FR soft nylon	
6	6	KRU06-99W2	12.8	55.5	20	12.8	11.7	38.5	17	10.4	4.2	8
8	8	KRU08-99W2	15.2	64.5	24.5	15.2	13.7	46	18.5	25.6	17.7	12
10	10	KRU10-99W2	18.5	71.5	27.5	18.5	16.1	50.5	21	40	28.4	18
12	12	KRU12-99W2	20.9	75.5	30	20.9	18.1	53.5	22	57.4	45.4	24

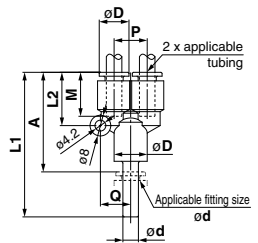

Plug-in Elbow: KRL-W2



Applicable tubing O.D. (mm)	Applicable fitting size ϕd	Model	$\phi D1$	$\phi D2$	L1	L2	A	M	Effective area (mm ²)		Weight (g)
									FR double layer	FR soft nylon	
6	6	KRL06-99W2	12.8	10	20	27.5	17	17	9.0	4.2	3
8	8	KRL08-99W2	15.2	12	22.5	31.5	21	18.5	21.6	14.9	5
10	10	KRL10-99W2	18.5	14	25.5	35.5	23.5	21	35.2	25.0	9
12	12	KRL12-99W2	20.9	16	27	37.5	26	22	50.2	39.7	10

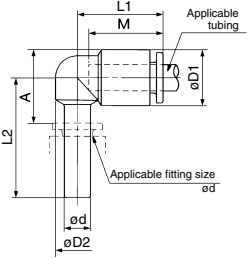

Extended Plug-in Elbow: KRW-W2



Applicable tubing O.D. (mm)	Applicable fitting size ϕd	Model	$\phi D1$	$\phi D2$	L1	L2	A	M	Effective area (mm ²)		Weight (g)
									FR double layer	FR soft nylon	
6	6	KRW06-99W2	12.8	10	20	41.5	31	17	9.0	4.2	4
8	8	KRW08-99W2	15.2	12	22.5	48	37	18.5	21.6	14.9	6
10	10	KRW10-99W2	18.5	14	25.5	55	43.5	21	35.2	25.0	9
12	12	KRW12-99W2	20.9	16	27	59.5	48	22	50.2	39.7	13

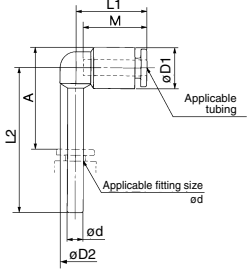

Plug-in Reducer: KRR-W2



Applicable tubing O.D. (mm)	Applicable fitting size ϕd	Model	$\phi D1$	L	A	M	Effective area (mm ²)		Weight (g)	
							FR double layer	FR soft nylon	FR double layer	FR soft nylon
6	8	KRR06-08W2	12.8	37	18.5	17	10.4	5.6	2.5	
	10	KRR06-10W2		39.5					9.3	
8	10	KRR08-10W2	15.2	41	20	18.5	26.1	18.0	4.0	
	12	KRR08-12W2		42					4.6	
10	12	KRR10-12W2	18.5	44.5	23	21	41.5	32.8	33	

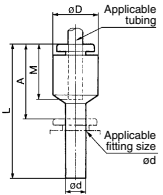

Bulkhead Union: KRE-W2



Applicable tubing O.D. (mm)	Model	T (M)	H (width across flats)	L	Mounting hole	M	Effective area (mm ²)		Weight (g)
							FR double layer	FR soft nylon	
6	KRE06-00W2	M14 x 1	17	34.5	15	17	10.4	5.6	33
8	KRE08-00W2	M16 x 1	19	38	17	18.5	26.1	18.0	52
10	KRE10-00W2	M20 x 1	24	42.5	21	21	41.5	29.5	70
12	KRE12-00W2	M22 x 1	27	44	23	22	58.3	46.1	90

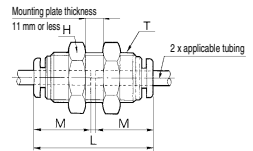

Bulkhead Connector: KRE-W2



Applicable tubing O.D. (mm)	Connection thread Rc	Model	T (M)	H1 (width across flats)	H2 (width across flats)	L1	L2	Mounting hole	M	Effective area (mm ²)		Weight (g)			
										FR double layer	FR soft nylon				
6	1/8	KRE06-01W2	M14 x 1	17	17	28	11	15	17	10.4	5.6	25			
	1/4	KRE06-02W2											31.5	15	40
	3/8	KRE06-03W2											33.5	17	29
8	1/8	KRE08-01W2	M16 x 1	17	27.5	7.5	17	17	18.5	26.1	18.0	28			
	1/4	KRE08-02W2											33	13	27
	3/8	KRE08-03W2											35	15	27
10	1/4	KRE10-02W2	M20 x 1	22	24	34.5	12.5	21	21	41.5	29.5	53			
	3/8	KRE10-03W2											36.5	15	67
	1/2	KRE10-04W2											37	14	92
12	3/8	KRE12-03W2	M22 x 1	24	27	37	14	23	22	58.3	46.1	92			
	1/2	KRE12-04W2											41	18	59

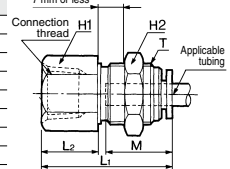

KQ2

KQB2

KS

KX

KM

KF

M

H/DL

L/LL

KC

KK

KK130

DM

KDM

KB

KR

KA

KQG2

KG

KFG2

MS

KKA

KP

LQ

MQR

T

IDK

KR-W2 Series

Plug: KRP



Applicable fitting size ϕD	Model	ϕD	L	A	Weight (g)
6	KRP-06	8	35	18	1
8	KRP-08	10	39	20.5	2
10	KRP-10	12	43	22	3.5
12	KRP-12	14	45.5	24	5

* Color: Green

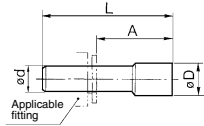

Spatter Cover 1: KR (Applicable tube: FR soft nylon)



Applicable fitting size	Model	ϕD	L	Weight (g)
6	KR-06C	15.5	9	0.9
8	KR-08C	17	9	1.0
10	KR-10C	20.8	10.5	1.5
12	KR-12C	22.8	10.5	1.6

* When tube insert parts are in line as KQU Union "Y", use KR-□□C1.

* Color: Gray

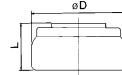

Spatter Cover 2: KR (Applicable tube: FR soft nylon, FR double layer)



Applicable fitting size	Model	L ₁	L ₂	ϕD
6	KR-06C1	18	13.7	12.8
8	KR-08C1	20	15.7	15
10	KR-10C1	22	17.2	18
12	KR-12C1	22	17.2	20

* Color: Gray

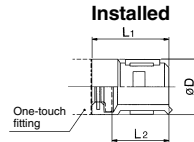

How to install

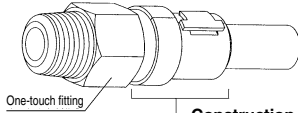

Construction of spatter cover

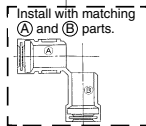

Related Equipment

Flame Resistant (Equivalent to UL-94 Standard V-0) Spatter Cover

(Applicable tubing: FR double layer/TRB, TRBU FR three layer/TRTU)

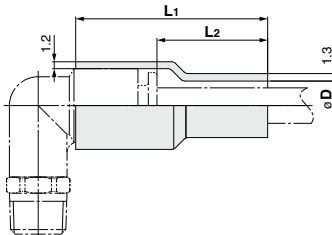

Model	Applicable tubing O.D.	ϕD	L ₁	L ₂	(mm)
KR-06C-X1807	6	8.5	33.3	19.2	
KR-08C-X1807	8	10.5	34.5	19.3	
KR-10C-X1807	10	12.5	37.2	20.2	
KR-12C-X1807	12	14.5	37.9	20.2	

Note 1) This product cannot be used with fittings such as KRU (union "Y") that have tube insertion parts close to each other.

For KRH (male connector) and KRE (bulkhead union) fittings, this product can only protect the release button and resin component parts.



Note 2) Sales unit: 10 pcs.

Flame Resistant (Equivalent to UL-94 Standard V-0) Spatter Cover

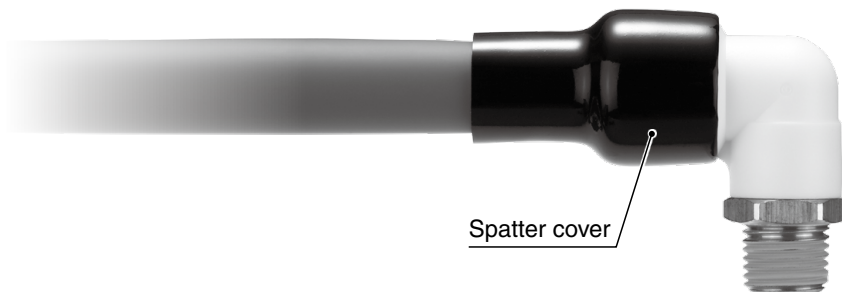
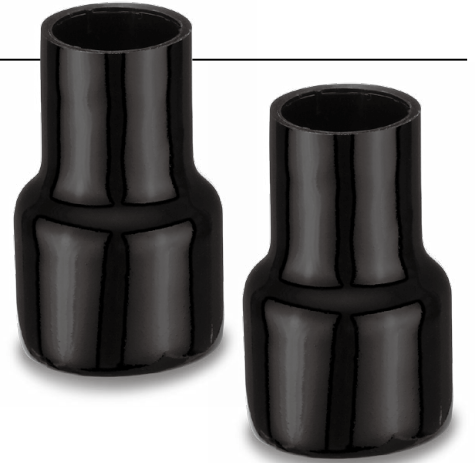
- Prevents the adhesion and entry of welding spatter
- Uses a flame-retardant material (Equivalent to UL-94 Standard V-0 Soft PVC)



■ Applicable model and size

		FR One-touch Fitting KR-W2 Series	Flame Resistant Speed Controller with One-touch Fitting AS-W2 Series	Flame Resistant Flat Head Screwdriver Adjustable Speed Controller AS-W2D Series
				
Applicable fitting Applicable speed controller	ø6	KR□06-□□W2*1	AS□2□1F-□-06W2	AS□2□1F-□-06W2D
	ø8	KR□08-□□W2*1	AS□2□1F-□-08W2	AS□2□1F-□-08W2D
	ø10	KR□10-□□W2*1	AS□2□1F-□-10W2	AS□2□1F-□-10W2D
	ø12	KR□12-□□W2*1	AS□2□1F-□-12W2	AS□2□1F-□-12W2D
Applicable tubing		FR double layer/TRB, TRBU FR three layer/TRTU		
Applicable tubing O.D. (Inner tubing O.D.)		ø6, ø8, ø10, ø12		
Ambient temperature		-5 to 60°C		

*1 This product cannot be used with fittings such as KRU (union "Y") that have tube insertion parts close to each other.
For KRH (male connector) and KRE (bulkhead union) fittings, this product can only protect the release button and resin component parts.

*2 Sales unit: 10 pcs.

KR-□C-X1807



21-E776

KR-□C-X1807

How to Order

KR-**08**C-X1807

• Applicable tubing O.D.

06	ø6
08	ø8
10	ø10
12	ø12

Dimensions

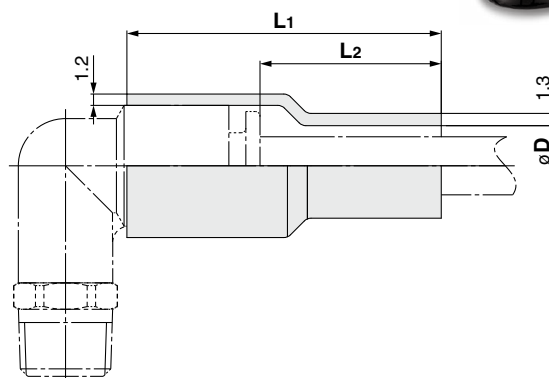

[mm]

Model	Applicable tubing O.D.	øD	L1	L2
KR-06C-X1807	6	8.5	33.3	19.2
KR-08C-X1807	8	10.5	34.5	19.3
KR-10C-X1807	10	12.5	37.2	20.2
KR-12C-X1807	12	14.5	37.9	20.2

⚠ Safety Instructions Be sure to read the "Handling Precautions for SMC Products" (M-E03-3) and "Operation Manual" before use.