

Lock-Up Valve

Series IL201/211/220

- The lock-up valve is used if any air source or air supply piping line failure occurs in the air operated process control line.

Single acting, Double acting: Retains pressure at the operating area as emergency operation until the air source is recovered to its normal state.

3 Port: Changes the supply port if a trouble occurs.

How to Order

IL 201 - [] 02 [] - []

Action

201	Single acting
211	Double acting
220	3 Port

Thread type

Nil	Rc
N	NPT*
F	G*

* Semi-standard

Port size

02	1/4
----	-----

Accessories

Nil	None
B	With bracket

Suffix

Nil	Standard
T	High temperature (-5 to 100°C)
L	Low temperature (-30 to 60°C)
S	External parts copper-free
ST	External parts copper-free/ High temperature (-5 to 100°C)
SL	External parts copper-free/ Low temperature (-30 to 60°C)

Standard Specifications

Model	IL201	IL211	IL220
Action	Single acting	Double acting	3 Port
Signal pressure	Max. 1.0 MPa <small>Note 1)</small>		
Set pressure range	0.14 to 0.7 MPa <small>Note 1)</small>		
Shut-off pneumatic circuit pressure	Max. 0.7 MPa		
Ambient and fluid temperature	-5 to 60°C		
Port size	Rc1/4		
Differential <small>Note 2)</small>	0.01 MPa		
Weight	0.45 kg	0.64 kg	0.7 kg

Note 1) Provide a differential pressure of 0.1 MPa or more between the signal pressure and set pressure. If the differential pressure is small, the internal part is worn out due to the structure of this product and the bleed amount from the exhaust port increases, which may affect the characteristics.

Note 2) Pressure difference between lock activated and lock released

Principle of Operation

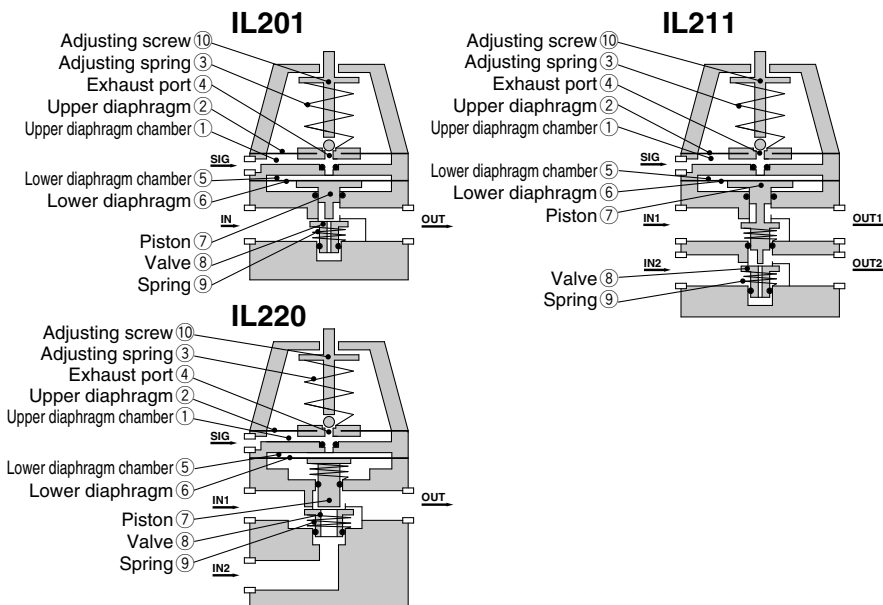

The signal air pressure enters the upper diaphragm chamber ① to generate a force. When this force is larger than the force generated by compressing the adjusting spring ③, the upper diaphragm ② is pushed up, the exhaust port ④ is closed, and the signal air pressure enters the lower diaphragm chamber ⑤ and acts the lower diaphragm ⑥. This pushes down the piston ⑦ to open the valve.

IL201 and IL211 enter the status, in which the flow path between IN and OUT is opened. IL220 enters the status, in which the flow path between IN1 and OUT is opened. If the signal air pressure drops to a level below the set pressure for some reason, the upper diaphragm ② is pushed down, the pressure inside the lower diaphragm chamber ⑤ is exhausted from the exhaust port ④, and the valve ⑧ is closed by the force of the spring ⑨. At this time, IN and OUT are shut down in IL201 and IL211. In IL220, IN1 and OUT are shut down, and the flow path between IN2 and OUT is opened. The set pressure is adjusted with the adjusting screw ⑩.

Series IL201/211/220

Construction

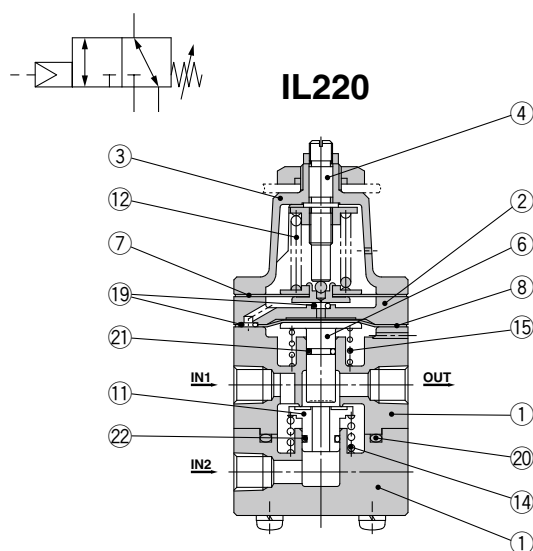
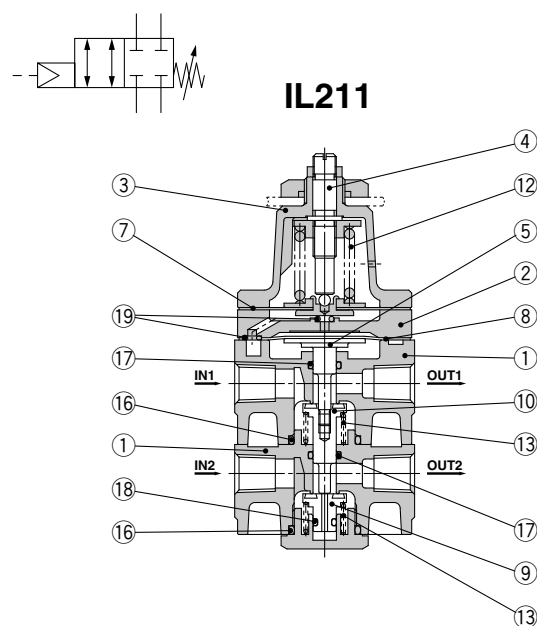
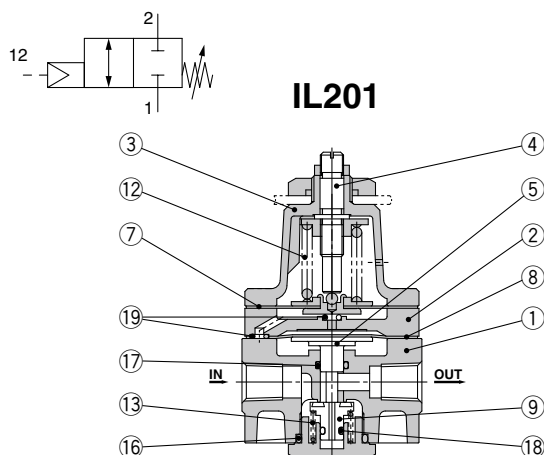

Component Parts

No.	Description	Material	Note
1	Body	Aluminum alloy	Silver baking finish
2	Pilot body	Aluminum alloy	Silver baking finish
3	Bonnet	Aluminum alloy	Silver baking finish
4	Adjusting screw	Stainless steel	
5	Piston	Brass	
6	Piston rod	Brass	
7	Diaphragm assembly	Aluminum alloy/Brass/NBR	Chromated
8	Diaphragm	NBR	
9	Piston valve	Brass/NBR	
10	Piston valve	Brass/NBR	
11	Valve	Brass/NBR	
12	Adjusting spring	Steel wire	Zinc chromated
13	Valve spring	Stainless steel	
14	Valve spring	Stainless steel	
15	Piston spring	Stainless steel	
16	O-ring	NBR	
17	O-ring	NBR	
18	O-ring	NBR	
19	O-ring	NBR	
20	O-ring	NBR	
21	O-ring	NBR	
22	O-ring	NBR	

Replacement Parts

Model	Order no.	Contents
IL201	KT-IL201	Set of left nos. ⑦, ⑧, ⑨, ⑫, ⑬, ⑯, ⑰, ⑱
IL211	KT-IL211	Set of left nos. ⑦, ⑧, ⑨, ⑩, ⑫, ⑬, ⑯, ⑰, ⑱
IL220	KT-IL220	Set of left nos. ⑦, ⑧, ⑪, ⑫, ⑭, ⑮, ⑰, ⑲, ⑳, ㉑, ㉒

Dimensions

IL201

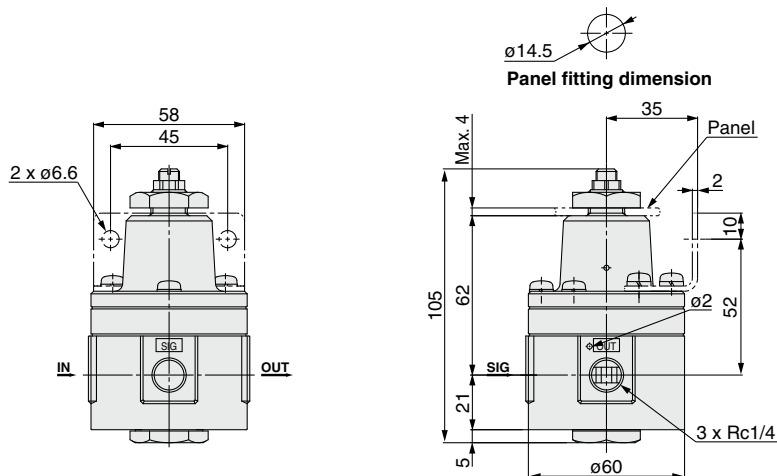

IL211

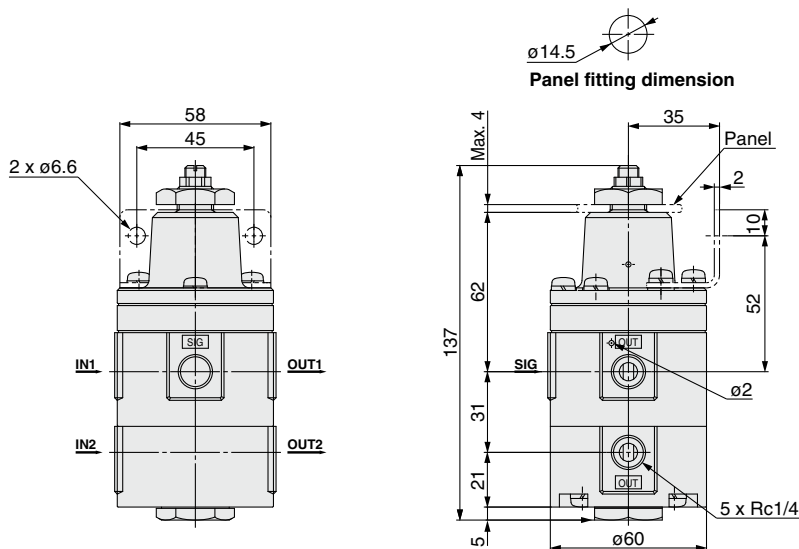

IL220

